



Title	Experimental Facility for Simulating the Initiation and Propagation of Fatigue Damage in Bituminous Road Paving Materials
Authors(s)	Hartman, Anton M., Nolan, D. B., Gilchrist, M. D.
Publication date	1999
Publication information	Hartman, Anton M., D. B. Nolan, and M. D. Gilchrist. "Experimental Facility for Simulating the Initiation and Propagation of Fatigue Damage in Bituminous Road Paving Materials." Trans Tech Publications, 1999. https://doi.org/10.4028/www.scientific.net/KEM.167-168.27 .
Publisher	Trans Tech Publications
Item record/more information	http://hdl.handle.net/10197/5941
Publisher's version (DOI)	10.4028/www.scientific.net/KEM.167-168.27

Downloaded 2026-05-01 23:37:47

The UCD community has made this article openly available. Please share how this access benefits you. Your story matters! (@ucd_oa)



© Some rights reserved. For more information

Experimental Facility for Simulating the Initiation and Propagation of Fatigue Damage in Bituminous Road Paving Materials

A.M. Hartman¹, D.B. Nolan¹ and M.D. Gilchrist^{1,2}

¹ Mechanical Engineering Department, University of College Dublin, Belfield, Dublin 4, Ireland

² corresponding author: Michael.Gilchrist@ucd.ie

Keywords: Bituminous Material, Hot Rolled Asphalt, Fatigue Damage

Abstract

An experimental simulation facility was designed and constructed for the purpose of investigating the initiation and development of fatigue damage in bituminous road paving materials. The design of the test facility was based upon a circular wheel track which incorporated four pavement monitoring stations.

Hot Rolled Asphalt specimens were manufactured and prepared for testing in order to verify the operation of this experimental facility. The variation of strains, deformations, and the distribution of pavement damage, in the form of cracking, were monitored digitally with increasing cycles of fatigue loading.

Failure of a pavement specimen was deemed to have occurred when a fatigue crack, which initiated on the under surface of the specimen due to local tensile strains, propagated through the complete thickness of the specimen and became apparent on the top surface.

1. INTRODUCTION

The materials used in the construction of most primary and secondary roads and motorways consist of sub-base, road base, base course, and wearing course layers, each of which contain different types and grades of asphaltic bitumen. The sub-base layer, usually crushed rock, provides a working platform for construction traffic to enable subsequent paving operations to be carried out. The road base layer(s) provides the main strength of the road pavement and it is common for different mixtures of graded aggregate and bitumen, which are carefully designed to ensure that the interlocking aggregate particles provide resistance to permanent deformation under traffic, to be used for different traffic and climatic conditions. The base course is principally required to remove any surface irregularities which may be present in the lower layers and provides a reasonably uniform surface, upon which the wearing course can be laid. The wearing course layer fulfils a number of significant functions, including the provision of adequate skid resistance and drainage of surface water. It is the surface roughness of exposed aggregate that provides proper skid resistance while the shape, size and orientation of the exposed aggregate provides the necessary drainage channels that permit surface water to flow away towards the drainage system.

Bitumen is a non-crystalline solid or viscous mixture of complex hydrocarbons that possess characteristic agglomerating properties, and it is obtained from crude petroleum by refining processes [1]. The main function of a bituminous binder is to bind aggregate particles together in a coherent layer able that is able to resist the principal road pavement distress mechanisms, namely; permanent deformation (rutting) and fatigue (cracking) [2].

The fatigue resistance of an asphalt-aggregate mixture is a measure of its ability to withstand repeated axle loadings without cracking and fracturing [3,4]. The majority of design procedures used to manufacture road pavement rely on empirical data that have been acquired through actual practice and are not based on rigorous mechanical constitutive relationships [5]. The complexity of the triaxial stress conditions within such a particulate reinforced viscoelastic composite material system is difficult to represent within laboratory test facilities although a number of simplifying test methods have been developed. These are summarised by Matthews & Monismith [6] and they include simple or supported flexural geometries, biaxial and diametral geometries, and rolling wheel test geometries. Full-scale experimental test facilities have also been developed based upon both linear and circular track configurations [7].

Rolling wheel test configurations that have been developed for establishing the performance of pavement materials include those based on reversing wheels [8] where a wheel traverses back and forth across a section of pavement, continuous wheels [9, 10] which travel in the same direction at a constant velocity along a section of pavement, and revolving wheels [11] which travel at a constant velocity along a circular section of pavement. Fatigue was observed by Van Dijk [8] to develop in three distinct phases, namely, the initiation of minor hairline cracks, followed by the development of these microcracks into wider macroscopic cracks which coalesce and form a network of cracks, and a final stage during which these macroscopic cracks propagate through the thickness of the pavement and lead to final catastrophic failure (i.e., loss of structural integrity) of the pavement. A convenient manner of classifying the network formed by fatigue cracks was established by Rowe [12], who monitored fatigue crack growth from the underside of pavement specimens and assigned a corresponding crack index that was based upon the total linear length of cracking in a 100 mm square area. A crack index of unity was assigned to an area containing no visual evidence of damage, 2 for an area containing less than 100 mm of crack length per area, 3 for between 100 and 200 mm, 4 for between 200 and 500 mm and 5 for an area containing more than 500 mm of crack length per area.

The experimental facility that has been designed within this present test programme is based on a circular wheel tracking arrangement that includes four pavement monitoring stations. An appropriate amount of fines, aggregates of different size and bitumen were mixed together to provide the necessary constituents for a Hot Rolled Asphalt mix which was compacted into four pavement specimens for fatigue testing. The design of this fatigue testing facility, together with the implementation of the testing procedure is described in the following sections.

2. DESIGN OF FATIGUE TESTING FACILITY

The essential design of the experimental fatigue testing facility involved the use of an existing circular motor driven table which spun two preloaded wheel fixtures around a track, which

was fitted with four sample stations as shown schematically in Fig. 1. This particular construction ensures that the simulated direction of travel across each pavement specimen is always identical and that the simulated traffic density and velocity, and the weight of axle loadings can also be maintained constant during testing. The substrata conditions under each pavement specimen are made from an elastomeric cushion that can be modified easily by using appropriate materials having different stiffness characteristics.

The facility was designed to operate on a dead load system with the rotating arms linked through hinged joints to the wheel fixtures. This ensures that the load automatically follows the deformation of the sample. Miniature wheels, 200 mm in diameter with solid rubber tyres, were fitted to the fixtures on the end of the rotating arms. Initial experiments were carried out using a 100 kg dead load which resulted in a tyre contact pressure of approximately 770 kPa. The width of the wheelpath is 36 mm and the tyre contact area was measured to be $1.3 \times 10^{-3} \text{ m}^2$ using static tyre imprints. The size of the contact area can be varied by changing the dead weight fixed to each wheel fixture. The large arc of the track, 3 m diameter, reduces the effect of cornering on the specimen while the influence of centrifugal forces are minimised by the relatively slow operating speed (approximately 4 km/h or 7 rpm).

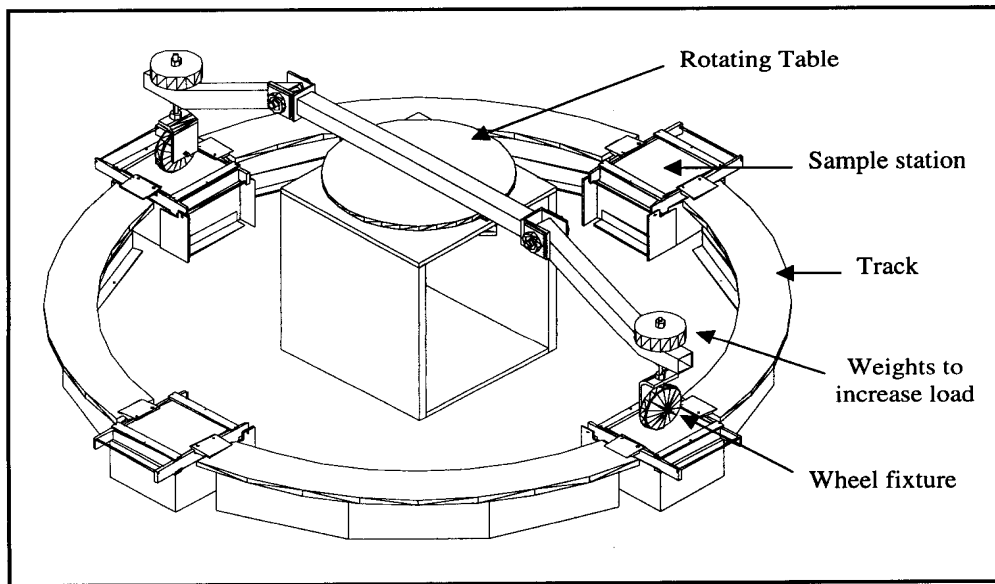

Figure 1: General layout of rotating fatigue testing facility. Four sample stations house pavement specimens on elastic foundations.

Four sample stations, each of which houses a pavement specimen, were incorporated into the track, in order to facilitate the simultaneous testing of multiple samples. An additional four sample stations, giving a total of eight, could be incorporated easily into this design, thereby doubling the number of specimens tested in a given period. However, the present paper is only concerned with the arrangement of four specimens. Each specimen is clamped in an aluminium frame along its edges, parallel to the tracking direction: this allows the specimen to deform under the influence of the dynamic load. The constraining clamps are fixed to the

foundation box, which contains an elastomeric foundation 170 mm deep with an elastic stiffness of 2 MPa. This represents a very weak foundation support but it does permit the pavement specimen to bend under the wheel load without deforming under the influence of gravity.

Fatigue damage which initiates on the underside of the pavement samples, is monitored by analysing digital photographs of the underside of the samples, which are captured at discrete intervals throughout a test. In order to facilitate and simplify the capturing of these images all four sample stations were designed in such a way that the samples could be turned on their sides. A specially constructed camera housing is then inserted into the sample station to provide identical optical distance and lighting conditions during specimen photography.

Data that is also monitored continuously during testing include measurements from strain gauges that are fixed to the bottom of the specimens. Strain levels can be changed either by adjusting the load, the specimen thickness or the foundation stiffness. During tracking, both the dynamic strain and the total strain were monitored. The dynamic strain is the per cycle peak to trough strain response of a sample whereas the total strain present within a sample includes permanent deformation as illustrated in Fig. 2. During a test sequence ambient and sample temperatures are also monitored. The number of load cycles are recorded by means of a micro-switch that is connected to a digital counter.

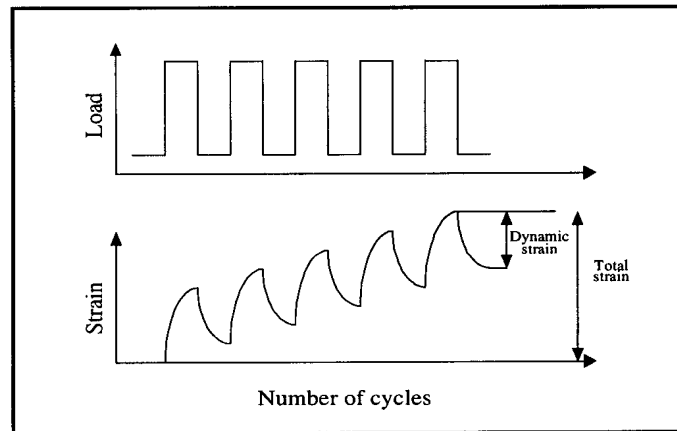

Figure 2: Typical development of dynamic and total strain during a fatigue test. The visco-elastic response of the bituminous pavement during a given cycle is apparent together with the gradual increase in strain over numerous load cycles (i.e., permanent deformation).

3. MATERIALS TESTED

To verify the operation of this experimental facility a set of four pavement specimens were manufactured and prepared for testing. A standard Irish Hot Rolled Asphalt wearing course mix (BS 594 [13]) was selected, the mixture proportions of which are given in Table 1. A

binder content towards the lower end of the design spectrum was chosen purposely to ensure a fatigue prone mixture. A Cooper Research Technology roller compactor was used to compact the slabs to dimensions of 305x305mm in area and 50mm deep.

Table 1: Mix constituents of 30% 14mm Hot Rolled Asphalt

% by weight passing sieve						
20mm	14mm	10mm	6.3mm	3.35mm	300 μ m	75 μ m
97.9	80.9	66.0	52.3	40.3	15.3	4.6
Bitumen content : 7.3% (50 pen)						
Target void content : 4% (by volume)						

In order to maximise the visibility of the cracks during image analysis it was necessary to paint the underside of the samples white, thereby ensuring that any cracks would appear black against a white background. Two 120-ohm strain gauges were fixed to the bottom of each slab, in the direction that was transverse to the wheel travel so that the maximum horizontal tensile strain could be monitored.

4. RESULTS AND DISCUSSION

Fatigue cracking was observed on the bottom surface of all the specimens that were tested. Rather than one main crack appearing under the wheel track, small individual cracks opened along the bottom of the sample, these interconnected and combined to form a manner of network cracking. Figure 3 shows the underside of a specimen after 200,000 load applications. It was observed that the strain gauges themselves had an effect on the direction in which the cracks propagate. The epoxy used to bond the strain gauges was stronger than the asphalt itself and because the cracks initiated on the bottom of the sample, some cracks grew around the epoxy as opposed to along the centre of the sample.

In previous experiments (Van Dijk [8] and Rowe [12]), the area of cracking that had developed during testing was assigned a crack index value in order to monitor increasing crack area throughout the test. The actual area of cracking produced was never measured. During the present investigation however, digital images were taken from the underside of the slab and these were processed through a series of image analysis procedures and the actual crack area was thus calculated. Figure 4 shows a typical plot of the crack area, expressed as a percentage of the total area monitored, as a function of the number of load applications. As expected, the crack area in the sample increases monotonically with the number of cycles. Crack initiation commenced after approximately 90,000 cycles after which stage the crack propagation developed at a relatively constant rate.

Figure 5 presents a typical result of the manner in which dynamic strain varied after different loading intervals. The strain results from the four pavement samples follow a similar trend to those determined by Rowe [12]. By correlating crack area measurements against strain it is observed that the initial strain value remains relatively constant at a value of approximately 90 μ strain until 90,000 cycles, at which stage small cracks begin to form on the bottom surface of the specimen. From this point onward, there is a definite and continuing increase in

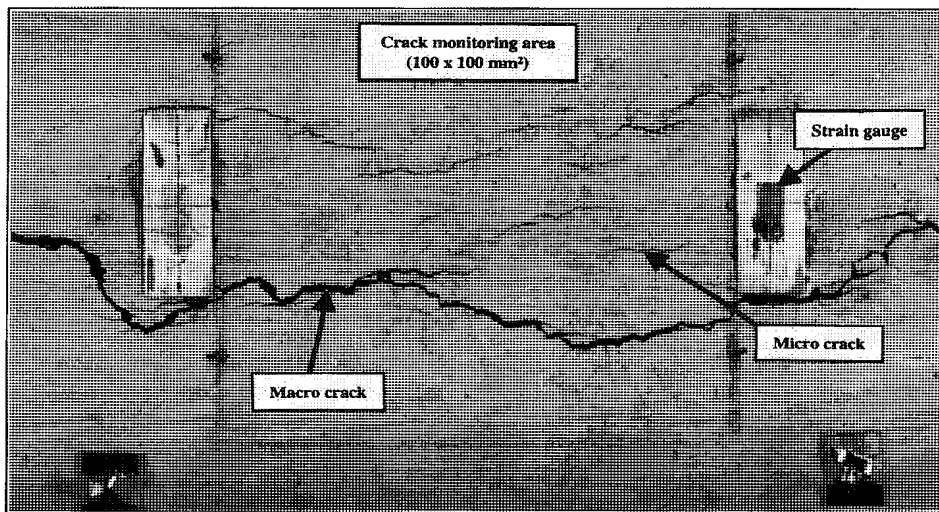

Figure 3: Development of fatigue cracks on the underside of a typical pavement specimen after 200,000 load applications.

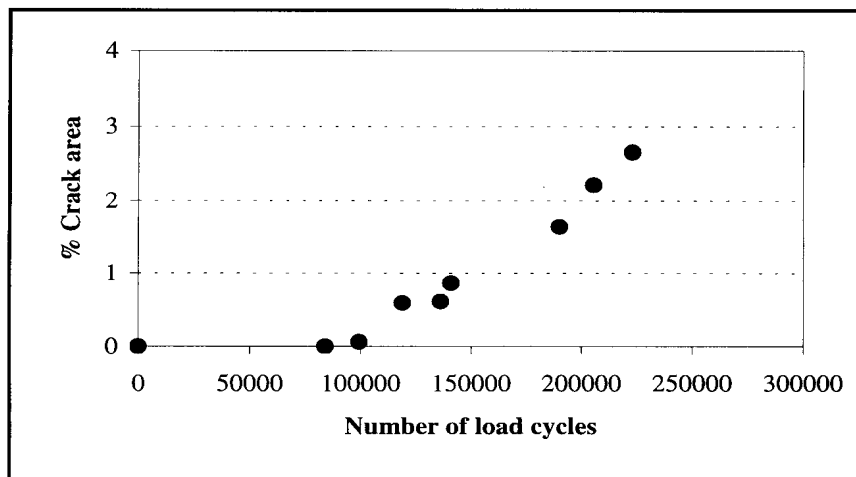

Figure 4: Variation of crack area with number of load cycles under a typical pavement specimen.

the strain detected by both gauges, implying that the cracks are propagating underneath the gauges. After approximately 130,000 cycles the strain begins to decrease showing that significant cracks are forming close to the gauge and that the material in this region is absorbing the strain causing the gauge to detect reduced levels of strain. The wheel came into

contact with the sample at the gauge 1 side of the specimen and left the sample at the gauge 2 side. The effect of dynamic loading by the wheel transferring from the track to the pavement sample may have had some influence in causing earlier failure damage around gauge 1. This particular sample was deemed to have failed after 225,000 cycles when a crack appeared on the top surface of the sample having propagated fully through the entire thickness of the sample.

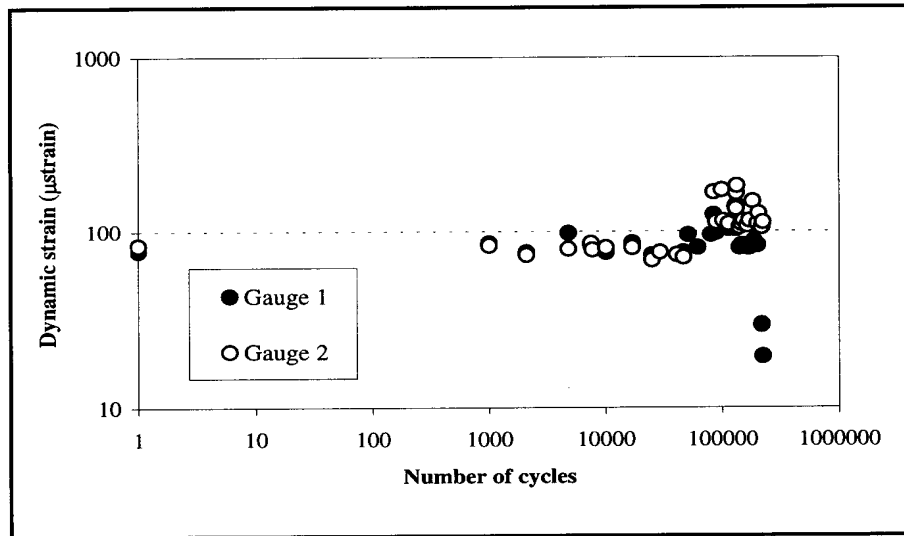

Figure 5: Variation of dynamic strain against the number of load applications.

5. CONCLUSION

A testing facility that can be used for the fatigue testing of asphalt slabs was designed, manufactured and commissioned. Unlike other standard laboratory tests that do not imitate the cracking behaviour observed under dynamic loading conditions (i.e., bending tests), this test allows fatigue cracks to propagate in a bi-directional state under a rolling wheel load. A method was developed for successfully monitoring the strain and crack area of the samples. An initial study on Hot Rolled Asphalt specimens was carried out and results were obtained quantifying the change in tensile strain and crack area with loading cycles. The general trend for the strain was to remain relatively constant until crack initiation at which point there was a small increase in the level of strain. During propagation the strain increased if cracks formed directly underneath the strain gauge but decreased if cracks formed adjacent to the gauge. This test facility proved to have the potential for successfully characterising the fatigue performance of road pavement mixtures.

6. REFERENCES

1. Jamieson, I.L. (1996), "Binders for bituminous mixtures", National Roads Authority, Ireland.
2. Gilchrist, M.D., Hartman, A.M. (1997), "Performance related test procedures for bituminous mixtures", Proceedings of the workshop on Performance Related Test Procedures of Bituminous Mixtures, Boole Press (214 pp.), Dublin, Ireland.
3. Hartman, A.M., Gilchrist, M.D. (1998), "Latest test procedures for bituminous mixtures", Journal of the Institute of Highways and Transportation, Vol. 44, No. 12, pp. 9-10.
4. Hartman, A.M., Gilchrist, M.D. (1998), "Performance related test procedures for predicting the mechanical degradation of bituminous mixtures", Journal of the Institute of Engineers of Ireland, Vol. 52, No. 8, pp. 33-39.
5. Deshpande, V.S., Cebon, D. (1999), "Steady-state constitutive relationship for idealised asphalt mixes", Mechanics of Materials, Vol. 31, pp. 271-287.
6. Matthews, J.M., Monismith, C.L. (1990), "Investigation of laboratory testing procedures for asphalt aggregate mixtures", Journal of Transportation Engineering, Vol. 119, No. 4, pp. 67-74.
7. Rao Tangella, S.C.S., Craus, J., Deacon, J.A., Monismith, C.L. (1990), "Summary report on fatigue response of asphalt mixtures". Strategic Highway Research Program Project A-003_A, Institute of Transportation Studies, University of California Berkeley.
8. Van Dijk, W. (1975), "Practical fatigue characterisation of bituminous mixes", Association of Asphalt Paving Technologists, Proceedings of the Technical Sessions, Vol. 38, pp. 38-74.
9. Hugo, F. (1994), "Some factors affecting the design and use of the Texas Mobile Load Simulator," ASTM STP 1225, American Society for Testing and Materials, Philadelphia, pp. 67-88.
10. Smit, A.d.F., Hugo, F., Van de Ven, M.F.C. (1996), "Scaled testing with the MMLS of rutting of a large aggregate base," South African Institute of Civil Engineers Journal, Vol. 38, No. 3, pp. 9-14.
11. Said, S.F., Johansson, S. (1997), "Mechanical properties of bitumen roadbase mixes", Proceedings of the 4th International Rilem symposium-MTBM, Lyon, France, pp. 211-215.
12. Rowe, G.M. (1994), "Performance of asphalt mixtures in the trapezoidal cantilever fatigue test", PhD Thesis, University of Nottingham, England.
13. BS 594: Part 1 (1992), "Hot rolled asphalt for roads and other paved areas – Specification for constituent materials and asphalt mixtures", British Standards Institution, London.