



Title	Planning and operating non-firm distributed generation
Authors(s)	Keane, Andrew, Zhou, Qiong, Bialek, Janusz W., O'Malley, Mark
Publication date	2009-12
Publication information	Keane, Andrew, Qiong Zhou, Janusz W. Bialek, and Mark O'Malley. "Planning and Operating Non-Firm Distributed Generation." Institution of Engineering and Technology, December 2009. https://doi.org/10.1049/iet-rpg.2008.0058 .
Publisher	Institution of Engineering and Technology
Item record/more information	http://hdl.handle.net/10197/3267
Publisher's statement	This paper is a preprint of a paper accepted by IET Renewable Power Generation and is subject to Institution of Engineering and Technology Copyright. When the final version is published, the copy of record will be available at IET Digital Library.
Publisher's version (DOI)	10.1049/iet-rpg.2008.0058

Downloaded 2026-05-02 00:26:57

The UCD community has made this article openly available. Please share how this access benefits you. Your story matters! (@ucd_oa)



© Some rights reserved. For more information

Planning and Operating Non-Firm Distributed Generation

Andrew Keane, Qiong Zhou, Janusz W. Bialek, and Mark O'Malley

Abstract

The penetration of Distributed Generation (DG) is increasing on distribution networks across the world. Non-firm access to the network is now being proposed as a cost effective way to facilitate DG. However, concerns remain about the operational details of non-firm access and also with regard to the financing of DG projects, which, by their nature, are not guaranteed permission to export power at all times. Here, the pertinent operational issues that arise with non-firm access are analysed. The index of coincidence is used to assess the probability of constraint breaches, through analysis of historical generation and load profiles. Further to this, a novel method is proposed, which minimises the cost to the generators of non-firm access through coordinated operation.

1 Introduction

With the advent of distributed generation (DG), the role of distribution networks is changing. They are now employed for the delivery and harvesting of energy. Traditionally, network operators have offered firm access to prospective generators. The amount of firm access granted under the connection agreement to a distributed generator is the level of output at which they can always operate without violating any of the constraints on the network. Non-firm access refers to output greater than this amount, at which generators may be allowed operate dependent on the system conditions throughout the year. There is a certain degree of risk for the generation developer in accepting non-firm access as they will only be allowed export power under certain operating conditions, the probability of which are often not known. This in turn presents problems for the financing of DG projects as there is a perceived risk to the revenues from the project. Here this risk is quantified and a new method for operating DG is proposed.

Congestion management is well established on transmission networks, with existing schemes in place [1]. However, given their traditionally passive nature, constraint management on distribution networks is much more unusual. Traditionally congestion management concentrated on thermal

constraints as that tended to be the dominant factor at transmission and sub-transmission networks. This paper concentrates at voltage constraints which may be dominant at the distribution level, especially in rural networks characterised by long, radial branches. Previous work has shown the scope for non-firm energy beyond the strict constraint limits and has optimised the allocation of this non-firm energy, such that the constraint breaches are reduced and hence the energy harvested is increased [2]. In [3], the operation of a proposed active management scheme is investigated on the Orkney islands in Scotland. The feasibility and benefits of non-firm access are highlighted as are the potentially complex operational issues surrounding the implementation of such a scheme. Previous work has examined the impact of distributed resources on congestion management on the transmission network in terms of contribution factors [4]. Other work has focused on the reliability worth of DG [5] and the consideration of an optimal operating strategy for DG on an hourly basis. Other operational issues have been investigated such as in [6], where a Monte Carlo simulation is employed to assess the impact of all possible DG operation conditions on the system. In [7], the operational issues of using multiple DG sources for voltage support are examined with a number of recommendations made.

Here, an assessment is made of the probability of key operating points occurring which will affect the viability of non firm access, essentially quantifying the risk to the generation developer. In this paper the output of those energy resources and load are analysed to assess the frequency of critical operating points, illustrating the considerable impact this has on the frequency and magnitude of constraint breaches. A method is also proposed to operate the non firm generation in a manner that will minimise the cost to the installed non firm DG sources. Both methods employ the bus voltage sensitivities to aid in determining the probable location, frequency and magnitude of voltage rise.

The calculation of the voltage sensitivities is described in Section 2. A method to assess the coincidence of critical operating points is given in Section 3, in particular the probability of the coincidence of critical operating points is analysed. The minimum cost method for the operation of non-firm generation is described in Section 4. A description of the test system is given in Section 5. Results and discussion are given in Section 6, with conclusions given in Section 7.

2 Voltage Sensitivities

Due to the low X/R ratio in distribution networks, the magnitudes of bus voltages are more dependent on the active power injections in the system than in the transmission system which tends to have higher X/R ratios. Voltage sensitivities are employed here to identify the contribution of

each generator to the constraint limits. Traditionally, voltage control on distribution networks is done by reactive power control or tap changing transformers. Active power curtailment is proposed here as an alternative method, which can be used if the alternative methods are unavailable or have been exhausted. The voltage sensitivities are used in the calculation of the critical operating ranges described in Section 3 and to calculate the amount of curtailment required by each generator under the minimum cost method described in Section 4.

Given a specific operating point, the Jacobian matrix used in Newton-Raphson load flow methods can reflect the sensitivities of bus voltage changes to power changes. For all the PQ mode buses (including load buses and those buses with distributed generators attached which are operating at the power factor mode), the bus voltage sensitivities to the active and reactive power injections, $\partial V/\partial P$ (μ) and $\partial V/\partial Q$, can be calculated from Equation (1).

$$\begin{bmatrix} \Delta\theta \\ \Delta\mathbf{V} \end{bmatrix} = \mathbf{J}^{-1} \begin{bmatrix} \Delta\mathbf{P} \\ \Delta\mathbf{Q} \end{bmatrix} = \begin{bmatrix} \frac{\partial\theta}{\partial\mathbf{P}} & \frac{\partial\theta}{\partial\mathbf{Q}} \\ \frac{\partial\mathbf{V}}{\partial\mathbf{P}} & \frac{\partial\mathbf{V}}{\partial\mathbf{Q}} \end{bmatrix} * \begin{bmatrix} \Delta\mathbf{P} \\ \Delta\mathbf{Q} \end{bmatrix} \quad (1)$$

Where \mathbf{V} is the vector of nodal voltages, θ is the vector of voltage angles and \mathbf{J} is the Jacobian matrix given by Equation (2).

$$\mathbf{J} = \begin{bmatrix} \frac{\partial\mathbf{P}}{\partial\theta} & \frac{\partial\mathbf{P}}{\partial\mathbf{V}} \\ \frac{\partial\mathbf{Q}}{\partial\theta} & \frac{\partial\mathbf{Q}}{\partial\mathbf{V}} \end{bmatrix} \quad (2)$$

The variable nature of load and DG means that power flows in the network will vary frequently. The Jacobian matrix in Equation (2) is dependent on the operating condition and will change accordingly. Hence, the sensitivity matrix in Equation (2) will also change with the operating condition, leading to a significant variation in the sensitivity values.

3 Coincidence of Critical Operating Points

The concept of coincidence and diversity of load has long been used in distribution planning [8]. Here these concepts are applied to network issues that arise with DG. The occurrence of constraint breaches is dependent on the system conditions at any given time. Voltage rise is the binding constraint for rural distribution networks and hence is the constraint which is dealt with here. The worst case scenario for voltage rise is maximum generation and minimum load. The levels of generation and load at any given time will therefore potentially cause voltage breaches. Here, the index of coincidence is used to assess the probability of the critical operating points occurring [9]. This gives an indication of the level of constraint breaches that can be expected.

The correlation of the various energy resources connected to the network has been employed in other work to measure the relationships between various energy resources and loads [1]. However, in this case the correlation coefficients do not give a good enough measure of how often the critical operating points occur. In terms of constraint management on the distribution network it is only the coincidence of maximum generation and minimum load that impacts the voltage constraint breaches. It is possible for two quantities to be positively correlated, but the coincidence of these two operating conditions may be infrequent. The advantage of the index of coincidence is that it is a more specific measure than a correlation coefficient. A key issue in the feasibility of non-firm DG projects is whether the financiers are willing to fund it given the increased risk to the projects revenues. The index of coincidence (IC) gives the probability of two events occurring simultaneously. By computing the probability distribution functions (PDFs) of annual historical data for energy resources and load, these key probabilities can be calculated.

A number of issues influence the probability of constraint breaches, for example the type of generation that connects will affect the level of constraint breaches. This has not been taken account of in previous methodologies and the impact of it is illustrated later in Section 6. A further issue that affects the level of constraint breaches is the feeding configuration on the network. Data from the network operator can show how often line outages occur, both planned and unplanned that require the network to be reconfigured. This network reconfiguration affects the operating points at which voltage constraint breaches occur, generally adversely. This is also factored into the formulation of the IC calculation shown below. By selecting the relevant section of these PDFs, in this case, maximum generation, minimum load, the index of coincidence can be computed as given in Equation (3).

$$\begin{aligned}
& P(MaxGen_N) \times P(MinLoad_N) \times P(LineIn) \\
& \quad + \\
& P(MaxGen_{N-1}) \times P(MinLoad_{N-1}) \times P(LineOut) \\
& \quad = IC_{MaxGen,MinLoad}
\end{aligned} \tag{3}$$

where $P(MaxGen_N)$ and $P(MinLoad_N)$ give the probability of the defined maximum generation and minimum load levels under normal feeding conditions occurring respectively. $P(MaxGen_{N-1})$ and $P(MinLoad_{N-1})$ give the same probabilities under N-1 feeding conditions. These levels are system dependent and will be defined later for the specific test system being analysed. They are dependent on the voltage sensitivity of the buses in the network, the calculation of which are described in Section 4. $P(LineIn)$ and $P(LineOut)$ give the probability of N and N-1 feeding conditions respectively, the sum of which add to 1. This IC gives us the probability of the critical

operating range occurring, thus giving the likelihood that constraint breaches will occur. The operating conditions defined as Max. Gen. and Min. Load are dependent on the amount of generation capacity connecting. The index is easily computed with historical data (if available) and gives an immediate indication of the likelihood that non-firm DG will have to curtail or that other control actions will be required. This information is valuable to both DG developers and network operators. Historical data may not be available if the generation is only being proposed, however, in the first instance data from nearby wind farms or other biomass/LFG generators could be employed. Results indicating how this IC can be applied to a actual network section are given in Section 6.

The information regarding the probability of constraint breaches will measure the risk for the non firm generation scheme and leave the DNO well equipped to operate the network safely on a non-firm basis. Further to quantifying the risk which non-firm DG faces in advance. The question arises of how the generators as a whole should be operated with non-firm access. This is dealt with in the following section, where it is considered how best to operate the network. A method is proposed which minimises the cost to the generators of non firm access.

4 Minimum Cost Curtailment

The curtailment method proposed here minimises the cost of a voltage management scheme. This method facilitates an overall increase in energy output from DG by avoiding the spilling of energy by non dispatchable generation, which in turn reduces the cost of curtailment. It utilises voltage sensitivities to calculate the contribution of each generator to the voltage rise. The cost of curtailment for each generator is also determined and is used to allocate the required curtailment between the generators such that the overall cost is minimised.

4.1 Cost of Curtailment

The cost of curtailment of each generator is calculated and used in conjunction with the voltage sensitivities to calculate how much energy should be curtailed. The result is the amount of curtailment that leads to the minimum overall cost. The cost of curtailment is dependent on a number of factors. Firstly, it is dependent on whether the plant is dispatchable or not. In the case of non-dispatchable generation, such as wind, the Generation Marginal Cost (GMC) is equal to the system marginal cost (€/MWh), i.e. the market price at that time. A dispatchable generator, such as biomass, can accommodate some of the curtailment for ‘free’.

There is a limit to this ‘free’ curtailment, dependent on the plant availability, load factor and

magnitude and frequency of constraint breaches. The average amount of curtailment required over a year can be estimated reasonably well through time series simulation of the network. It is impossible to predict ahead of time exactly when instances of overvoltage will occur. However, the total amount of constraint breaches over a year is assumed to be a relatively stable value from year to year, given the predictable nature of both the load and overall DG energy output. As such, the calculation of the GMC is based on historical levels of required curtailment. The calculation of the generation marginal cost of the l th energy resource (GMC_l) is given in Equation (4).

$$GMC_l = \frac{CurtReq - FreeCurt}{CurtReq} MP + CycleCost_l \quad l \forall M. \quad (4)$$

Where $CurtReq$ and $FreeCurt$ give the amount of energy to be curtailed and the amount of energy that can be accommodated for free respectively. MP gives the price paid to the generator in the market and M is the set of all available energy resources. $CycleCost_l$ is the cost of cycling and is explained below. If $FreeCurt$ is greater than $CurtReq$, then the generator can accommodate more curtailment than is required and GMC_l is equal to the cycling cost. It can be seen that in the case of non dispatchable generation where generally $FreeCurt = 0$, $GMC_{Wind} = MP + CycleCost_{Wind}$. In the case of a dispatchable generator, it can be seen that the GMC will be based on the fraction of $CurtReq$ that can be accommodated for free. $FreeCurt$ is determined by analysing the dispatchable generator's historical output profile. An estimate of $CurtReq$ can be determined based on the magnitude of overvoltage experienced historically. The GMC_l essentially gives the opportunity cost of using the l th generator for curtailment.

The ability to increase or reduce the output of an electricity generator is limited by the thermal and mechanical stresses imposed on the unit during the ramping process. The higher the change in output over a particular period of time, the more onerous the stresses imposed on the unit and the more likely component failures and outages become. Hence, if a dispatchable generator is required to take on more of the curtailment then the stress on the unit will increase. This cost to the dispatchable generator is included in the form of a cycling cost [10]. Even small changes in output are significant as many small cycles add up and contribute to real damage [11]. Using the methodology described in [12], the cost of cycling a biomass generator is calculated here. Similarly there is a cost associated with cycling other thermal generators, which could also be calculated in a similar fashion.

4.2 Curtailment Method

The proportion of generation to curtail is calculated based on the bus voltage sensitivity and generation marginal cost of each generator, leading to a sensitivity value in kV/€ as shown in Equation 5.

$$\beta_{ijl} = \frac{\mu_{ij}}{GMC_{jl}} \quad i \forall N, j \forall N, l \forall M. \quad (5)$$

Where β_{ijl} (kV/€) gives the voltage sensitivity in terms of cost of using the l th energy resource connected at the j th bus to reduce the voltage at the i th bus. GMC_{jl} is the generation marginal cost of the l th energy resource connected to the j th bus ($GMC_{jl} > 0$). M & N give the number of energy resources and buses respectively. The sensitivity values, given by μ_{ij} , have the units of kV/MWh as curtailment is assigned for a specific time period. It is evident from Equation (5) that the higher the generation marginal cost, the more expensive it is to reduce the voltage using the l th energy resource and vice versa. The voltage sensitivity μ_{ij} (kV/MW) defines how much the voltage changes at the i th bus per MW change in active power at the j th bus. β_{ijl} is a similar sensitivity with the amount the voltage changes now defined in terms of cost. It can be seen from Equation (5) that if GMC_l is low, then that leads to a high value of β_{ijl} and therefore from Equation (6) below, the l th generator would be allocated a large proportion of the curtailment.

$$Prop_{jl} = \frac{\beta_{ijl}P_{jl}}{\Delta V_i} \quad i \forall N, j \forall N, l \forall M. \quad (6)$$

Where $Prop_{jl}$ is the proportion of the total voltage rise at the i th bus (ΔV_i) allocated to the l th energy resource at the j th bus ($0 \leq Prop_{jl} \leq 1, \sum_{l=1}^M \sum_{j=1}^N Prop_{jl} = 1$). P_{jl} gives the output at the j th bus of the l th energy resource at the time of curtailment. The overvoltage, given by ΔV_i , is divided between the contributing generators. β is used to attribute the proportion of the voltage rise to each generator based on cost, but μ is still required to curtail the generators by their allotted amount. This leads to Equation (7) which gives the total amount of curtailment required for a voltage breach at the i th bus.

$$P_{Curtail_j} = \sum_{l=1}^M \frac{Prop_{jl}\Delta V_i}{\mu_{ij}} \quad i \forall N. \quad (7)$$

Where $P_{Curtail_j}$ is the amount of curtailment at the j th bus for a voltage breach at the i th bus. The amount of curtailment allocated to the j th bus ($P_{Curtail_j}$ is based on the estimated levels of free curtailment that the dispatchable generators can accommodate and the predicted levels of curtailment based on historical profiles. Essentially the curtailment is allocated based on the previous years data. In Section 6 this minimum cost methodology is compared to other congestion management methods that have been applied to the distribution network in [13].

There are a number of dispatchable distributed generators that would have the capability to operate in this manner; biomass, LFG and hydro. All three have a limited energy resource and will have a projected total output for the year. The annual output of a landfill gas (LFG) plant is dependent on the rate of the landfill gas generation at the site. This gas is collected in a system of pipes on site and pumped to a nearby gas turbine [14]. There are a number of types of biomass plant, but in the case of an industrial residue plant, the output of the generator may be influenced by the operating schedule of the site it serves and also on the availability of its fuel. As a result these plants will not be completely flexible. This is also relevant for combined heat and power (CHP) plant.

5 Test System & Data

A sample section of network is modelled and simulated to illustrate the measures and methods described in Sections 3 & 4. The network section analysed is a typical rural section of the Irish 38kV distribution network, shown in Figure 1. The line impedances for the network are given in the Appendix in Table 4. Annual simulations are carried out to compare the performance of the minimum cost methodology and the various curtailment methods detailed in [13]. These are the minimum energy, proportional and minimum distance methods. The simulations consist of load flow calculations carried out for half hourly data. The data used in the simulations includes actual historical active and reactive power profiles for each of the energy resources and loads, along with data on frequency of N-1 outages and the sending voltage at the transmission station. The generation and load profiles employed for the time series simulation were obtained from [15, 16]. The power factor of DG is taken as fixed, as is the case with DG in the UK and Ireland.

6 Results & Discussion

6.1 Voltage Sensitivities

The first step is to calculate the bus voltage sensitivities to power injections (μ_{ij}). This will identify if the buses where the generation is connecting may lead to voltage constraint breaches. The sensitivities calculated for this assessment are for the minimum load level as this is the relevant operating condition. It is evident from the network topology in Figure 1 that the voltage at some buses will be independent of generation at other buses. Table 1 shows the voltage sensitivity of each bus to power injections at all the buses under normal feeding conditions, rounded to four decimal places. The buses with the highest sensitivities and interdependence can be identified as

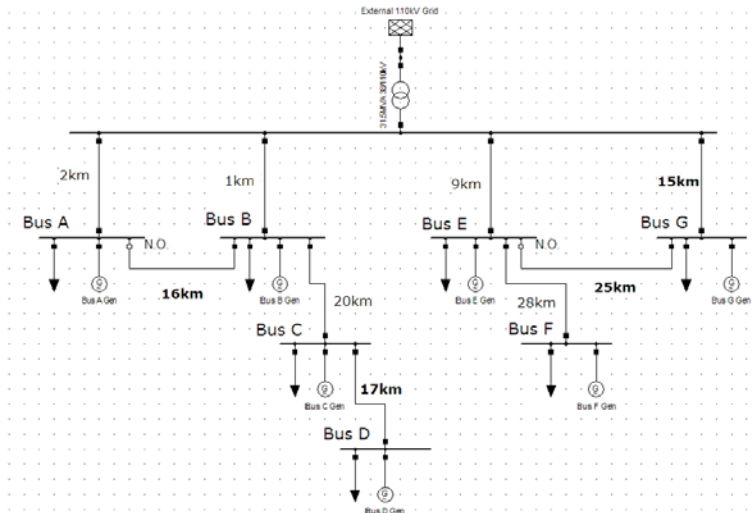

Figure 1: 38kV 7 bus radial distribution network diagram

buses C & D. The maximum allowable voltage is 1.1pu, the generation is curtailed such that the voltage is brought back to 1.095pu in the case of overvoltage.

Table 1: Bus Voltage Sensitivities μ_{ij} (kV/MW) and Base Values (kV)

Bus	A	B	C	D	E	F	G	Base
A	0.0437	0	0	0	0	0	0	41.0
B	0	0.0272	0	0	0	0	0	41.0
C	0	0	0.154	0.1258	0	0	0	41.0
D	0	0	0.118	0.1354	0	0	0	41.0
E	0	0	0	0	0.0754	0.0473	0	41.0
F	0	0	0	0	0.0415	0.2089	0	41.0
G	0	0	0	0	0	0	0.105	41.0

It is worth noting from the matrix of sensitivity values that it is only at certain buses that voltage constraint issues will occur and there is scope for connecting generation at other buses with little technical difficulty. A calculation of the product of the generation capacity and the sensitivity, combined with the base values indicates that voltage constraint breaches will occur. This is essential in predicting the critical operating ranges for the IC calculation. The generation scenario chosen later will be at buses C & D to illustrate the impact of non-firm access. This calculation allows the critical range of generation and load levels for each feeding condition to be

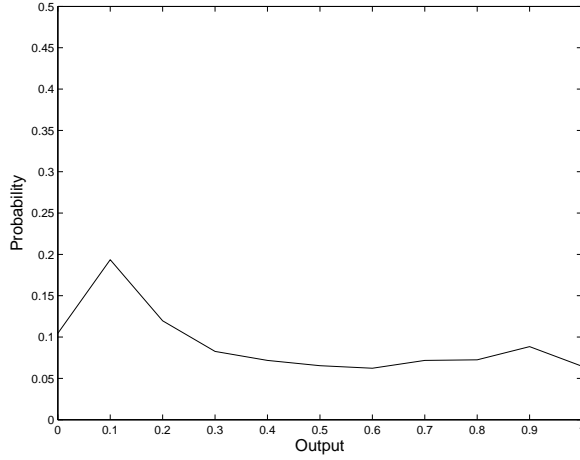

Figure 2: Probability Distribution Function for Wind over one year

estimated, which are given for the case under study in Section 6.2. The calculation of the N-1 cases utilise the voltage sensitivities for the N-1 conditions.

6.2 Indices of Coincidence

The indices of coincidence are calculated to determine the probability of constraint breaches. Utilising the N voltage sensitivities shown in Table 1 and N-1 sensitivities, the critical operating ranges are estimated. The probability of these ranges is then calculated from the probability distribution functions of the various resources. The annual PDFs of the wind, biomass and load profile at the buses on the network are shown in Figures 2, 3 and 4 respectively. They have been calculated from one years worth of historical data, if possible a number of consecutive years data would be preferable, but one years worth of data was all that was available to the authors. The relevant operating regions are selected from these and their probabilities. The relevant operating condition depends on the feeding condition as shown in Equation (3).

By discretising these PDFs the probability of the critical range of operating values can be calculated and then combined to give the index of coincidence of key operating ranges, which will then be used to calculate the risk to the developers of operating on a non-firm basis. The scenario of 12MW wind and 6.5MW of biomass at buses C & D respectively is assumed. This leads to the following definition of the key operating ranges given below in Equations (8) & (9) A conservative approach was adopted in the determination of these ranges with the coincidence of the upper limit of the load range and the lower limit of the generation range resulting in overvoltage.

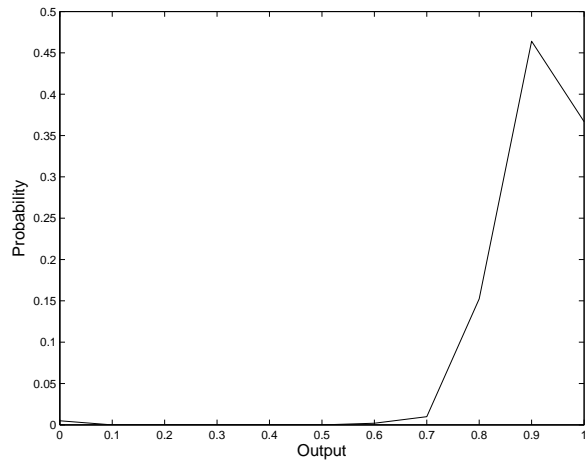

Figure 3: Probability Distribution Function for Biomass over one year

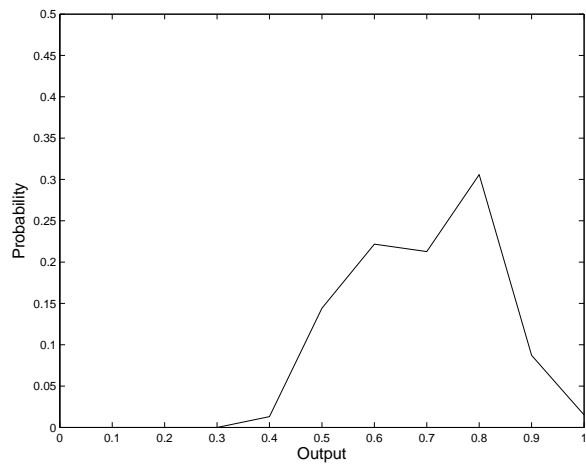

Figure 4: Probability Distribution Function for Load over one year

$$\begin{aligned}
P(MaxGen_N) &= P(0.85 \leq Gen \leq 1.0), \\
P(MinLoad_N) &= P(0.3 \leq Load \leq 0.60),
\end{aligned}
\tag{8}$$

and

$$\begin{aligned}
P(MaxGen_{N-1}) &= P(0.80 \leq Gen \leq 1.0), \\
P(MinLoad_{N-1}) &= P(0.3 \leq Load \leq 0.65)
\end{aligned}
\tag{9}$$

Utilising Equation (3) the IC is calculated for this scenario.

Table 2: Index of Coincidence of Maximum Generation, Minimum Load Operating Conditions for Wind and Biomass case

	Probability
Min. Load	0.267
Max. Gen.	0.202
Lines In	0.80
Min. Load N-1	0.379
Max. Gen. N-1	0.27
Line Out	0.20
IC	0.0636

Table 2 shows the indices of coincidence for these operating points. It can be seen that the overall probability of constraint breaches is 6.36%. While the biomass is likely to be at a high level, wind generation is by its nature much more variable. An illustrative scenario will now be described to illustrate how best to operate the non-firm generation given that it has been established that there is a low probability of constraint breaches. It can be seen that the probability of constraint breaches is 0.0623. As an illustrative example the wind generation was replaced with a LFG plant and the index of coincidence was recalculated. In this case the index of coincidence is considerably higher with a value of 0.1142. These figures quantify that a variable, low load factor resource such as wind, the coincidence of the maximum generation minimum load operating points is relatively infrequent with a 6.36% probability of it occurring. When the wind is replaced with LFG generation, which has a load factor of 0.8, the probability of the critical operating range and hence constraint breaches rises significantly to 11.4%. The PDF of the LFG generator is shown in Figure 5.

The relatively low index of coincidence indicated that the non firm connection of the 12MW wind generator and 6MW biomass generator is viable. The next section describes the implemen-

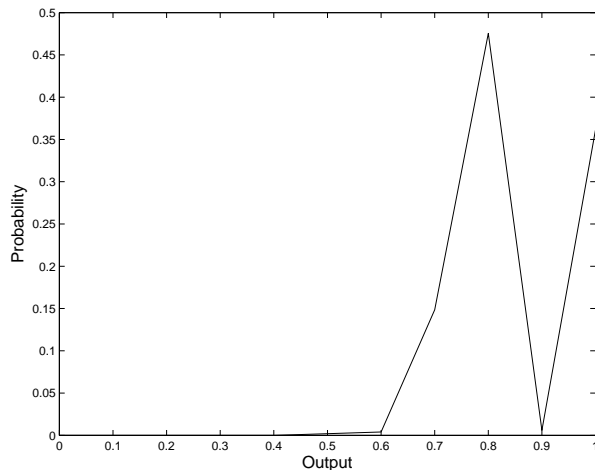

Figure 5: Probability Distribution Function for Landfill Gas over one year

tation of the minimum cost method utilising the voltage sensitivities.

6.3 Minimum Cost Method

From Equation 2, it can be seen that there will be a variation in the bus voltage sensitivities dependent on the operating condition. The impact of these variations are assessed here by using sensitivity values that are recalculated throughout the year. The variance of the voltage sensitivity is dependent how the operating conditions vary at each bus throughout the year, hence, the amount and type of generation connected at each bus will have a significant impact on it. For this case the market price is set to its average value for the year.

The network shown in Figure 1 was simulated over a given year through half hourly load flow calculations and the amount and cost of energy curtailed under each of the methods compared. *CurtailReq* is calculated to be 2,439MWh based on the historical minimum cost curtailment requirement and *FreeCurtail* is calculated to be 2,051MWh based on the historical operating profile of the biomass plant. Both figures are based on constraint breaches at bus C. The cycling cost was estimated to be approximately €12 per MWh cycled [12]. A number of rules were drawn up for the redispatch of the dispatchable generation. The rules only permit the generator to ramp up when the load is above a certain level, the wind generation is below a certain level and the generator is available. These rules ensure that when the generator ramps up its output, it does not result in new constraint breaches and that the redispatch is done in a realistic manner. Table 3 shows the new amounts of curtailed energy under the different curtailment methods when the varying voltage sensitivities are employed.

Table 3: Curtailed Energy (MWh) with Variable Voltage Sensitivities

	Bio	Wind	Total	Cost (€)
Min. Energy	0	1,810.1	1,810.1	99,011
Min. Distance	901.6	1,014.7	1,919.3	85,034
Proportional	981.8	943.6	1,925.3	83,767
Min. Cost	1,239.4	714.7	1,954.0	68,839

It can be seen that, in terms of energy, the minimum energy curtailment method has the least amount of energy curtailed, with the minimum cost method incurring the most curtailment. However, given that the energy curtailed under the minimum energy method is wind energy, it is the most expensive option the energy is wholly spilled. The minimum cost method is cheaper because they employ the dispatchable generator, in this case biomass, to initially curtail the energy. The energy is not lost because the biomass generator regains this energy at a later stage. The biomass plant was redispatched throughout the year and it was found that it could successfully accommodate its allotted level of curtailment, by ramping up its output whenever it was permitted, based on the operating constraints of thermal plant described in Section 4. The impact of the GMC can be seen in Table 3 with the cheaper biomass curtailment being employed much more in the minimum cost approach. This leads to a 24.4% reduction in cost over the minimum energy method for the case shown.

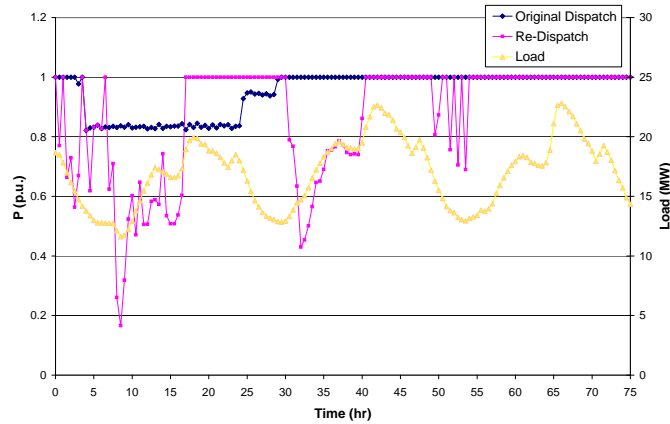

Figure 6: Comparison of Biomass Output Profiles

Figure 6 shows a comparison between the original biomass output profile and the redispatched profile over a sample period of the year. The impact of the redispatch can be seen with the redispatch profile reducing its output when required and ramping up when possible to regain the

curtailed energy.

7 Conclusion

The advent of non-firm access to distribution network will require new methods of distribution operation. The voltage sensitivity is crucial to indicating the location and severity of overvoltages. Here the index of coincidence of key operating points has been calculated to aid in the planning of non-firm generation projects which gives the probability of voltage constraint breaches. A minimum cost curtailment method for DG voltage management is proposed here that facilitates the operation of non firm DG by avoiding the spilling of energy by non dispatchable generation. This in turn reduces the cost of curtailment. It has been shown here that the risk of non firm generation can be estimated in advance through analysis of the network and generation output profiles. A significant saving in the operation of DG is possible if the flexibility of the available dispatchable generation is utilised.

Acknowledgments

The authors gratefully acknowledge ESB Networks and Eirgrid for the data provided and their colleagues in the Electricity Research Centre, in particular Eleanor Denny, for their help with this work.

Appendix

References

- [1] R. Christie, B. Wollenberg, and I. Wangensteen, "Transmission management in the deregulated environment," *Proc. of the IEEE*, vol. 2, no. 88, pp. 170–195, Feb. 2000.
- [2] A. Keane and M. O'Malley, "Optimal utilisation of distribution networks for energy harvesting," *IEEE Trans. Power Syst.*, vol. 22, no. 1, pp. 467–475, 2007.
- [3] University of Strathclyde, "Facilitate generation connections on Orkney by automatic distribution network management," Department of Trade & Industry UK, Tech. Rep. K/EL/00311/00/00, 2004.

Table 4: Test System Data

	Lines	
	R (Ω)	X (Ω)
Tx-A	1.19	1.176
Tx-B	0.18	0.53
Tx-E	3.36	3.53
Tx-G	5.59	5.88
A-B	5.97	6.27
B-C	9.32	9.80
C-D	2.074	6.052
E-F	10.44	10.98
E-G	3.65	8.90

- [4] J. Liu, M. Salama, and R. Mansour, "Identify the impact of distributed resources on congestion management," *IEEE Trans. Power Deliv.*, vol. 20, no. 3, pp. 1998–2005, Jul 2005.
- [5] I. S. Bae, J. O. Kim, J. C. Kim, and C. Singh, "Optimal operating strategy for distributed generation considering hourly reliability worth," *IEEE Transactions on Power Systems*, vol. 19, no. 1, pp. 287–292, Feb 2004.
- [6] W. El-Khattam, Y. Hegazy, and M. M. A. Salama, "Investigating distributed generation systems performance using monte carlo simulation," *IEEE Trans. Power Syst.*, vol. 21, no. 2, pp. 524–532, May 2006.
- [7] M. Kashem and G. Ledwich, "Multiple distributed generators for distribution feeder voltage support," *IEEE Transactions on Power Systems*, vol. 20, no. 3, pp. 676–684, Sept. 2005.
- [8] H. L. Willis, *Power Distribution Planning Reference Book*, 2nd ed. Marcel Dekker, New York, U.S.A., 2004.
- [9] W. F. Friedman, "The index of coincidence and its applications to cryptanalysis," *Cryptographic Series*, no. 49, 1922.
- [10] S. Lefton, P. Besuner, and G. Grimsrud, "Understand what it really costs to cycle fossil-fired units," *Power*, vol. 141, no. 2, pp. 41–42, 1997.

- [11] P. Grimsrud and S. Lefton, “Economics of cycling 101: what do you need to know about cycling costs and why?” *APTECH Engineering Technical Paper TP098*, <http://www.aptecheng.com>, 1995.
- [12] E. Denny and M. O’Malley, “Quantifying the total net benefits of grid integrated wind,” *IEEE Trans. Power Syst.*, vol. 22, no. 2, pp. 605–615, May 2007.
- [13] Q. Zhou and J. Bialek, “Generation curtailment to manage voltage constraints in distribution networks,” *IEE Proc.-Gener. Transm. Distrib.*, vol. 1, no. 3, pp. 492–498, May 2007.
- [14] ATSDR. (2006) Landfill gas primer. [Online]. Available: <http://www.atsdr.cdc.gov/>
- [15] Eirgrid. (2007) Eirgrid system information. [Online]. Available: <http://www.eirgrid.com/>
- [16] ESB Networks. (2007) ESB Networks infrastructure. [Online]. Available: <http://www.esb.ie/esbnetworks/>