



Title	Economic and technical criteria for designing future off-shore HVDC grids
Authors(s)	Bell, Keith, Cirio, Diego, Denis, Anne-Marie, He, Lina, Liu, Chen-Ching, Migliavacca, Gianluigi, Moreira, Carlos, Panciatici, Patrick
Publication date	2010-10-11
Publication information	Bell, Keith, Diego Cirio, Anne-Marie Denis, Lina He, Chen-Ching Liu, Gianluigi Migliavacca, Carlos Moreira, and Patrick Panciatici. "Economic and Technical Criteria for Designing Future Off-Shore HVDC Grids." IEEE, October 11, 2010. https://doi.org/10.1109/ISGTEUROPE.2010.5638958 .
Conference details	Paper presented at the IEEE PES Conference on Innovative Smart Grid Technologies Europe October 11-13, 2010, Lindholmen Science Park, Gothenburg, Sweden
Publisher	IEEE
Item record/more information	http://hdl.handle.net/10197/3201
Publisher's statement	ersonal use of this material is permitted. Permission from IEEE must be obtained for all other uses, in any current or future media, including reprinting/republishing this material for advertising or promotional purposes, creating new collective works, for resale or redistribution to servers or lists, or reuse of any copyrighted component of this work in other works.
Publisher's version (DOI)	10.1109/ISGTEUROPE.2010.5638958

Downloaded 2026-05-01 23:33:26

The UCD community has made this article openly available. Please share how this access benefits you. Your story matters! (@ucd_oa)



© Some rights reserved. For more information

Economic and technical criteria for designing future off-shore HVDC grids

K. Bell, D. Cirio, A.M. Denis, *Member, IEEE*, L. He, C. C. Liu, *Fellow, IEEE*, G. Migliavacca, C. Moreira, and P. Panciatici, *Member IEEE*

Abstract– In the scope of a recently launched European Research Project, a team of experts from public laboratories and TSO is in charge of defining the concepts and methodological approaches to design and analyse the technical and economic feasibility of future HVDC grids.

This work aims at identifying, assessing and comparing several possible HVDC network topologies, with appropriate control and protection schemes, able to collect wind energy on large areas, transmit it at the best points to the AC grid and provide the necessary ancillary services for optimising the DC / AC interconnection in normal and disturbed conditions.

The methodology adopted for the study and presented in this paper will focus on three main items:

1. identify and assess the economic drivers for the development of off-shore HVDC networks
2. identify the requirements for an optimal operation of the AC / DC interconnected power systems under normal and emergency conditions
3. conceptualise the coordinated control / command and protection plans for HVDC networks

This paper gives a comprehensive view of the issues and tasks to be addressed during the run of the project.

Index Terms– off-shore wind-farms, HVDC grids, economic design, risk assessment, secure operation, ancillary services, probabilistic tools.

I. INTRODUCTION

The European Union is committed to reducing its overall emissions to 20% below 1990 levels by 2020. It has also set itself the target of increasing the share of renewables in primary energy use to 20% by 2020. This leads to an estimated share of 35% of electricity from renewable sources, with an estimated share of 15% for wind energy.

In line with these commitments taken late 2008, wind energy will be the most prominent renewable resource in Europe in next decades. A fair share of this wind capacity should be growingly installed offshore for several reasons: higher resource level and probably higher wind “quality”, lack of remaining promising sites onshore, growing public opposition against future onshore wind parks.

The European Wind Energy Association publishes a vision bringing the amount of installed off-shore capacity from 2 GW

end 2009, up to 40 GW in 2020, with an ambitious target of 150 GW in 2030.

The emergence of these huge amounts of off-shore generation raises new technical challenges. Indeed above a given range of power and distance, the only technical solution is the HVDC technology instead of the HVAC one, and more likely the promising VSC (Voltage Source Converter) technology, provided losses and fault clearing are properly handled in forthcoming years. More details on VSC and LCC (Line Commutated Converters) are respectively available in [9-12] and [7- 8].

The radial connection of off-shore generation appears more and more as being a limited solution in terms of flexibility to reach the EU goals. If some projects are studying the possibility of multi-terminal solutions [1], no MTDC (Multi-Terminal Direct Current) links have ever been experimented over the world for collecting and transmitting wind energy.

As a consequence, this project will tackle critical transmission network issues : how should the HVDC network be designed to collect efficiently wind power over the sea, how should this wind power be transmitted on to the mainland grid without generating additional congestions, how should the HVDC system be protected and controlled to limit the consequences of faulty devices, what will be the impact of the HVDC system on the AC mainland grid in case of major disturbances , how will the interconnected DC / AC power system behave in terms of stability, will the technology developed by manufacturers be ready to meet the technical requirements resulting from this new generation of networks. Therefore, the electrical transmission sector is facing today a huge challenge in terms of feasibility and secure operation of future HVDC networks for transmitting wind energy and in-feeding it to the AC grid. Major research efforts are still needed in these fields.

This paper contributes at giving a comprehensive view of the issues and tasks that will be performed on next three years in the framework of the European project.

Section II describes the drivers for designing HVDC networks and the questions raised about their deployment. Section III focuses on the requirements for an optimal operation of the AC / DC interconnected power systems. Finally, section IV deals with coordinated control/command and protection plans to be implemented on HVDC networks to meet the optimal operation as depicted in section III.

Keith Bell is with University of Strathclyde Glasgow, UK - Diego Cirio and Gianluigi. Migliavacca are with ERSE Milano, Italy - Anne-Marie Denis and Patrick Panciatici are with RTE Versailles, France – Lina He and Chen Ching Liu are with University College of Dublin – Dublin, Ireland – Carlos Moreira is with Inesc Porto, Portugal.

II. DRIVERS FOR DESIGNING HVDC GRIDS

A. Economic benefit assessment

The first set of questions deals with the design of an HVDC network and the assessment, from a European power system point of view, of the benefits brought by an HVDC network aiming at collecting wind power, in-feeding it to the mainland AC grid and providing additional interconnection capacity between distant areas.

A detailed analysis of the main drivers for developing such offshore networks has to be made on a qualitative and quantitative basis. The first necessity is to provide a quantification of the net import or export needs in different regions of Europe and forms the basis for analysing the need for major investments in interconnection between European regions. Such an understanding based on statistically valid modelling will be critical to justify the major investments needed and, in turn, fully realize the Europe-wide diversity in power needs and resources thus contributing to fulfil European carbon reduction targets. In view of the likely high capacity of interconnection required, not least to make very long connections economically viable, HVDC is the principle technology expected to realize these interconnections. Such off-shore networks promise greater flexibility and, for high volumes of offshore wind farms, greater cost effectiveness of transmission than simple point-to-point connections, either between AC systems or from single wind farms to shore.

The economic analysis will address offshore wind conditions, mitigation of variability upon geographical zones, cost/benefit assessments for offshore real grid structures compared to point-to-point connectors, as well as a hierarchical classification of different HVDC grid topologies in terms of economic interest, investment cost and feasibility. Figure 1 gives an example of two elementary topologies to be investigated in detail.

B. Methodology for an economic design and assessment

It has been widely argued that the meeting of European targets for renewable energy will depend on coordination of electricity generation resources across the continent and the exploitation of the most favorable regions for renewables. Particularly important but not limited to this will be the countries around the northern seas, especially in the British Isles which, without significantly enhanced interconnection capacity to other countries, may not be able to exploit the levels of wind penetration envisaged for 2020 and beyond.

Given the geography of north western Europe, new interconnection capacity is almost certain to depend on HVDC and raises questions about the degree of meshing of DC interconnections that is desirable and possible.

While the need for enhanced interconnection capacity seems qualitatively true, if the significant investment that long-distance and high capacity offshore interconnection requires is to be made and the long path to regulatory integration is to be traversed successfully, some indicative quantification of the extent of need and expected benefits should be undertaken.

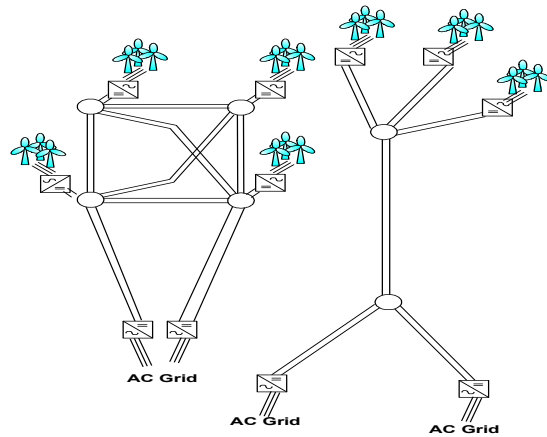

Fig. 1. Two elementary HVDC topologies to be investigated

Moreover, as our European project begins to answer key technical questions and demonstrate solutions to problems, the cost-benefit assessment should be updated with greater precision and view to whether the scaling up of ideas can be achieved in such a way as to make a material difference to reduction of Europe's carbon impact.

The benefits will concern the meeting of the net import or export needs for different regions of Europe. Quantification of these needs must be based on statistically valid modeling, in particular of available wind power, and demonstration of the effects of diversity in power needs and resources. This will be done by using models of wind intermittency and diversity alongside probabilistic assessments of conventional generation availability, including hydro, load variation and the potential usage of large-scale energy storage such as pumped storage.

The main idea concerns the following: if there were no constraints placed by limits to network capacity on regional or international flows of electric power in Europe, how much power might flow? These flows will exhibit wide variation due to variation in wind speeds, rainfall and water storage capacity, changes in use of electricity through a day and through a year and planned and unplanned unavailability of thermal generation.

While market conditions show significant volatility, both the likely median and the extremes of need for network capacity can be estimated by study of the following two conditions:

- minimum import into a region with limited available generation required to meet demand for electricity in that region;
- maximum export from a region with surplus available generation relative to demand in that region.

A key dependency will be the availability of wind data that adequately captures both temporal and spatial variation. Such data are particularly sparse for offshore. Of critical importance, therefore, will be the development of novel methods for spatial interpolation. Such methods are currently being explored at the University of Strathclyde but will require further work to be applied in a European context (see[4]).

In order that the potential benefits of diversity among European electricity generation resources can be accurately assessed, another dependency will be on the modeling of conventional generation. While thermal generation can be adequately represented via a two-state model ('in service' or

‘out of service’), models of hydro generation and the associated water flows and storage will be required.

A final dependency will be on demand variation. Key data concerns peak national demands and the time of occurrence of the peak. While study of typical winter days would provide immediate benefit in the study, further benefit would accrue from additional study of off-peak conditions when the surplus of available wind power over local demand is likely to be at its highest.

Modeling of the use of hydro power and management of wind variability requires sequential simulation. A detailed model of all nodes and branches on the European system and those postulated for exploitation of resource diversity across the continent would require extensive data and considerable computation time for each time interval in a sequential simulation. Furthermore, the uncertainties associated with wind power would require many such simulations. The study will therefore facilitate an appreciation of the impact of diversity of generation resources and scheduling by making use of an abstracted representation of the European regions and assessing net transfers across key boundaries that can be compared with present day net transfer capability. Alongside the wind characterization developed in our project, use will be made of a tool developed by RTE – ANTARES [5 - 6].

This model was developed by RTE to tackle two subjects of growing concern for TSO’s, especially in the light of the responsibilities that the 3rd energy package puts on them at the prospective stage: on the one hand, assessment of the fundamentals of the economic behavior of the power system (actual contribution of each kind of generation technology to the energy mix, savings in fuel costs to expect from grid reinforcements, etc.) ; on the other hand, assessment of the risk of power shortage that the system may have to face if it were to meet adverse generation conditions (low availability of thermal plants, windless episode, draught, etc.) at times of very high demand (e.g. winter cold spell during week-days). The first field of application of ANTARES is therefore market-oriented, while the latter is more pertaining to regulatory concerns (Security of Supply -SoS). Being a Monte-Carlo sequential simulator, the way the tool proceeds is to go through a large number of yearly scenarios made of consistent sets of 8760-hour time-series (wind power, availability of thermal plants, level of demand, etc.), while determining the overall least-cost trajectory for the whole interconnected system (unit commitment and optimal dispatch for every generation park).

The simulation process involves therefore two very different stages :

- a) Generation of Time-series for all of the variables of the techno-economic problem, with a resolution of one hour.
- b) Determination of the economic optimum for the whole system, with a resolution of one hour and within a time-frame of one day to one week.

Unlike that of thermal power plants availability (obtained through a classical two-state Markovian model), the generation of Time-series for intermittent generation relies on the use of correlated diffusion processes. The parameters of the stochastic differential equation defining each process are set so as to make it stationary, with a given desired marginal

law and exponential autocorrelation function. For the purpose of this European project studies, the capabilities of the built-in Time-series generator of ANTARES have been extended so as to make it possible to simulate stationary processes whose marginal law is of the Weibull type, which is widely acknowledged as a fitting distribution for the modulus of wind speed in many locations and heights. Once generated, such wind speed times-series may be rightly converted into wind power time-series, using the ad hoc diagrams of the local machines.

Within the project framework it will be possible to put these simulation capabilities at work on many-fold scenarios aiming at assessing the economic synergies between off-shore DC grid development, off-shore wind generation and interconnected on-shore systems. The matter of the modeling of the spatial correlations between the different variables of the problem (especially those of the different interconnected wind fields) and of their influence on the economic behavior of the system is likely to be a cornerstone of the studies, from which both theoretical and practical results of interest are expected.

C. Reliability of the VPP

The whole system composed of the wind farms in remote areas and the HVDC grid can conceptually be defined as a multi-terminal VPP connected to the mainland grid with onshore terminals possibly located far from each other and in different countries.

An important part of the economic assessment is the “reliability” evaluation of this VPP. This term refers to indices expressing the expected “yield” of the wind farms connected to the offshore grid, e.g. in terms of energy delivered to the onshore AC grid, under increasingly complex modelling hypotheses. The VPP would present some freedom in the dispatch of the power injection from the wind farms to the mainland AC grid, thus bringing a significant benefit to the reliability indices. Indeed, the HVDC grid may offer some degree of redundancy, allowing some power transfer through alternative paths even in case of faults leading to the permanent outage of components such as converters and cables. The requirements are a meshed structure of the HVDC grid and the “smartness” of the master control system logic. The same control flexibility can be exploited to direct the power injections in order to prevent congestions of the AC grid, thereby exploiting the available wind at the best. All of the above mentioned factors should be encompassed in reliability evaluations, in order to get a more and more accurate estimation of the benefits achievable from the installation. Moreover, offshore wind farms can be remote from each other. In this case, depending on the wind conditions, the overall power generated and transmitted via the HVDC grid may undergo some “natural” smoothing effect which is beneficial for the overall system balancing.

Several kinds of reliability indices can be defined: (1) indices considering only the wind behaviour, with all components in service; (2) indices considering wind variations and generator outages; (3) indices accounting for the previous factors, plus HVDC grid outages (cables, converters); (4) indices also accounting for the mainland AC system congestions. As more factors are considered, the expected

performances may decrease. It can be noted that, by carrying out analyses with increasingly complex models (i.e. (1) to (4)), one can identify the factors that most affect the indices. Results of such “progressive” analyses can suggest useful considerations on the VPP profitability and design.

A major preliminary objective is to develop a suitable approach allowing to assess the “inherent” performances of different DC grid solutions, i.e. the reliability performances of the DC grid, when neglecting the AC grid transfer capacity limits. By this approach different candidate grid topologies and control strategies can be evaluated and ranked, considering the exogenous influencing conditions, such as for instance, the fact that fault rates of some offshore components are higher in winter.

The performance reduction due to the onshore grid congestions (analysis type (4)) can be seen as a further step, very much dependent on the external AC network, which of course must be considered when developing specific projects.

The investigations described above will be carried out with a new tool, derived from the REMARK software by ERSE (see [2-3]) but extended in order to be able to conduct reliability analyses on a mixed AC/DC network layout. The idea is first to test the VPP layout stand alone (DC network, analyses (1)-(3)) and then to frame this VPP into a real context in which it is connected to an on-shore AC network, in order to test the resulting behaviour of the system (analysis (4)). The tool conducts reliability analyses based on a non-sequential Monte Carlo, which has noticeable advantages in terms of computational time when simulating a large system. The optimal power flow (OPF) model adopts a simplified direct current model of the transmission network: however, all links are fully represented and all power transits are always subject to the imposed technical constraints. The OPF operates in a probabilistic environment in order to verify the system reliability taking into account the probability of outages of each component and the different wind conditions. Suitable VPP reliability indices will be evaluated, such as the annual expected energy delivered to the AC network, respectively without and with grid outages. The simulation will account for the correlated behaviour of wind farms and the control logic in case of DC grid components unavailability.

The main results of REMARK are currently:

- Flow-related characteristics: Power exchanges between market zones, duration and incremental cost of network congestions, average power flows on all transmission links (interconnections, lines and transformers), energy produced and CO₂ emissions
- Economic indicators: LMP (Locational Marginal Prices), social welfare, consumer surplus, producer surplus, generation costs
- Reliability indicators: LOLP (Loss Of Load Probability), LOLE (Loss Of Load Expectation) and EENS (Expected Energy Not Supplied) .

III. OPTIMAL OPERATION OF THE DC / AC POWER SYSTEMS

A. Optimal in-feeds to the mainland grid

One of the main purposes of our project is to investigate and assess from a TSO point of view, the expectable

advantages brought by an offshore grid and its different possible topologies, when compared to radial connections. All aspects dealing with security, risk assessment, wind generation variability, ancillary services at the DC /AC converters, as well as specific market issues will be addressed.

The global optimization of the interconnected DC/AC power systems will be addressed regarding mainly:

- control of the multiple DC/AC injectors depending on the connected off-shore wind turbine generation and status of the mainland grid,
- congestion management on the AC grid by appropriate coordinate actions on the DC/AC injectors,
- commercial exchanges through the HVDC grid and contribution to the European electricity market,
- losses management.

The performances of the optimal control of DC/AC injectors will have direct consequences on the economical characteristics of DC grids.

B. Risk assessment

Security of operation of the interconnected AC-DC system is of paramount importance for the HVDC grid viability. Because of the very stressed system conditions that may result with large power injections from HVDC networks, security can be achieved by a combination of probabilistic risk assessment methods and advanced defence systems.

By combining contingency severity, quantified by suitable impact definitions, and contingency probability, risk indices provide a deep insight into security problems [22-23-24]. Thus they can provide trends for operating the network closer to its limits while guaranteeing operational security.

For instance, bad weather conditions may increase line outage probability compared to the case of good weather. In such cases, contingencies become more “risky” and may call for preventive actions. On the other hand, severity indices can reflect both the magnitude and number of post-fault violations. Post-fault profiles can be defined: for instance a single, large violation which is different from several slight violations. Further, different severity indices can be defined to account for different phenomena (e.g. overloads, voltages out of range, stability margins) thus providing a wide coverage of the security issues. Expected available time for curative actions after a contingency has occurred is also a key factor to include in the evaluations: more severe contingencies, requiring faster actions, present higher risk. By risk-based approaches, the range of considered contingencies can be extended: one can consider N-1 and also virtually any N-k contingency depending on its probability.

Contingencies can eventually be ranked according to risk indices. If the risk is excessive with respect to defined standards, either preventive actions or curative actions have to be planned, the economic objective being to optimise at any time the operation cost of the power system, including re-dispatching cost, and for some very rare and severe situations without any possible actions, the load-shedding cost.

Within the project, risk assessment methodologies will be applied to the case of HVDC injections.

C. Ancillary services

a) Frequency control

In AC grids, system frequency deviation is an indication of the unbalance between load and generation following system disturbances, and therefore it makes possible the design and identification of quite expedite control loops for power/frequency control. Regarding off-shore DC grids, specific control algorithms must be identified and tested in order to “translate” frequency disturbances in on-shore AC-grid into the DC network. DC voltage will presumably be the most suited signal for that. The architecture of the HVDC grid must be taken into account in this problem. Regarding the response of the DC/AC power electronic interfaces, two specific situations must be addressed. Primary frequency control can be thought as:

1) a supplementary inertia control loop to be introduced in each off-shore wind turbine control system. Such a methodology will exploit the kinetic energy stored in the rotating mass of wind turbines.

2) power exchanges/support with ac neighbouring systems through the exploitation of the dc offshore network.

b) Voltage support

In normal conditions, voltage support has to be offered at the DC/AC connecting points using VSC-based injectors. In addition, in the event of a fault in the AC transmission network, the generators may experience large over currents and power swings both during the fault and after its clearance by the appropriate switchgear. The type of response of the generators in an AC grid during and in the moments subsequent to voltage sag depends on its type (fixed speed generator, double fed induction generator, full converter generator). In the case of DC connections to shore, ride through fault performance must be focused on the development of innovative technological solutions in order for the DC link converter systems to be capable of providing fault ride through requirements in case of balanced and unbalanced faults through the injection into the AC grid of reactive current. Regarding unbalanced faults, it is important to develop innovative control techniques such that reactive power is independently injected in each phase of the system in order to avoid over-voltages in the non-faulted phases.

c) Contribution for the damping of system oscillations

When connecting massive amounts of wind power to a system, there is the need to guarantee that transient performance is not reduced and problems of small signal stability do not arise. The most frequent cause of this kind of instability is the lack of damping of the so-called electromechanical modes of oscillation, which are related with low frequency (0.1-2Hz) power oscillations that occur among the rotors of synchronous machines. One of the cases where a reduction of damping can take place is related with a situation where the connection of wind power in one area of the grid, replacing conventional production located in other areas, increases the power flows through weak interconnection lines. This situation may occur in the future, for example, in the north of Europe with the construction of large offshore wind farms. Power system stabilizers (PSS) installed in the

excitation of synchronous generators is still one of the most cost effective solution for providing supplementary damping. However, in a system with large share of wind generation these devices may no longer be able to provide the necessary additional damping. Therefore, it may be necessary to implement damping functions in the HVDC grid control-command.

IV. PROTECTIONS AND COORDINATED CONTROL PLANS

Unlike AC networks, the establishment of power flows inside a DC grid are the direct consequences of the actions of the control of its converter stations. This coordinated control is also the key element for providing ancillary services as described in section III and a high level of robustness for the HVDC grid, when facing internal or external disturbances. The complexity of the overall control-system increases with the number of terminals involved in the DC grid.

The current possibilities and limits have to be carefully investigated, for instance how many converters can be operated and coordinated for specific network topologies, how easily the control system can evolve and be adapted when new generating units are committed, what happens when storms are jeopardising large amounts of wind generation, when the HVDC network is developed according to new topologies, or when different manufacturers are equipping parts of the same HVDC grid.

Therefore, a detailed study of the characteristics of the coordinated control-command is essential in order to assess the technical feasibility of HVDC basic topologies and identify the research efforts that are still needed to overcome potentially remaining barriers.

A. Robustness of HVDC networks to disturbances

HVDC networks will have to fulfil all the security requirements needed for the reliability of the whole interconnected system. The local control and protection plans of these networks will therefore be a crucial point for their potential future development. If not handled correctly, the security might be a very heavy barrier or even a definitive obstacle for the interconnection of HVDC grids to the AC mainland grid. All the situations related to internal or external short-circuits, N-1 conditions, frequency deviation, etc. should be analyzed and taken into account carefully. Moreover, wind-farms should be kept connected in the greatest majority of “system” disturbances in relation or not with weather factors.

B. Designing protection and defence plan

In a grid with multi-terminal DC wind farms, a detailed protection design and relay coordination method for internal DC faults has been proposed [13]. Based on four parallel-operated offshore wind farms with HVDC link, a control scheme using a designed rectifier current regulator (RCR) based on HVDC is presented to enhance system stability [14]. VSC based HVDC interconnection demonstrates an ability to provide fault ride through for offshore wind farms [15].

a) Coordinated protection

In a HVDC offshore network, if there is a fault on the transmission line near the point of common connection (PCC),

the PCC voltage will decline. The reduced PCC voltage decreases the power transfer capability of the HVDC link. Since the input power from the wind farm does not change instantaneously, this in turn increases the wind turbine terminal voltage. Excessive voltage at the wind turbine terminal may trip wind turbines by its over-voltage protection, which will cause a deficit in generation and possible voltage and frequency problems. To prevent tripping of the wind turbines, the conceptual design of a coordinated protection scheme is proposed in this paper.

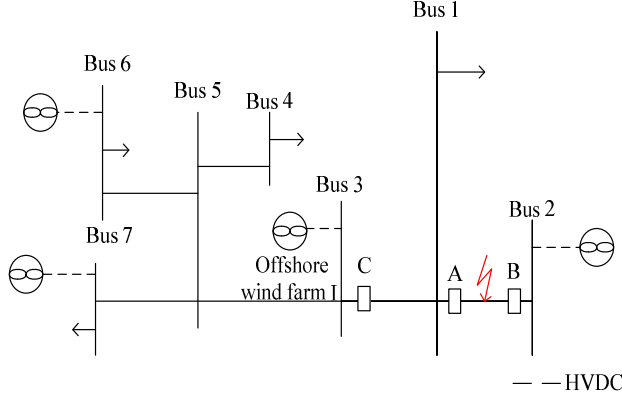

Fig. 2. Example of HVDC offshore wind network

For a HVDC offshore wind network, such as the example in Fig. 2, 4 offshore wind farms are connected at Buses 2, 3, 6 and 7, respectively, with HVDC links. If there is a fault, say, on line 1-2, the fault is a Zone 2 fault for relay C. The voltage at Bus 3 is expected to fall. One can calculate the voltage of Bus 3 using the Z-bus method [16]. If the voltage is below the PCC threshold for tripping of wind turbines, offshore wind farm at Bus 3 may trip at Zone 2 operating time (The operating time of the relay for Zone 2 fault is about 30 cycles [17]). However, HVDC provides a control for offshore wind farms. HVDC control can raise the voltage of Bus 3 quickly (The adjusting time of HVDC is in the order of ms [18]) and maintain the Bus 3 voltage above the tripping threshold. The procedure of the coordinated protection system is as follows:

- Detect the location of fault for a faulted HVDC offshore wind network;
- Calculate voltages at the buses with HVDC offshore wind farm connections near the fault;
- Compare the bus voltage V_{bus} and the threshold voltage of tripping wind farm V_{th} ;

If $V_{bus} > V_{th}$, retune; if $V_{bus} < V_{th}$, grid side VSC based

- HVDC will send reactive power to raise V_{bus} until $V_{bus} \geq V_{th}$;
- Return.

Otherwise, the use of special protection schemes is recommended for line 1-2 [19].

b) Defence System

Integration of offshore wind farms will increase the complexity of the interconnected system. Then inherent intermittence of wind and the large-scale and long-distance power transmission lead to new sources of vulnerability. It is therefore necessary to design a defence system to reduce the threat against the security of integrated offshore wind-AC

mainland grid. The defence system includes two major functions: vulnerability assessment and self-healing.

c) Vulnerability Assessment

HVDC offshore wind network is assessed with possible sources of vulnerability, such as natural events, and failures in protection/control facilities. To determine the cascaded sequence of events leading to a catastrophic outage, a wide range of scenarios and contingencies of the HVDC offshore wind network need to be simulated. These studies should incorporate system analysis tool and relay simulation methods. Some specific scenarios are shown in Table 1. Based on the results of the simulation, the vulnerability index in terms of severity and likelihood is calculated.

TABLE I
EXAMPLE EVENTS OF POSSIBLE HVDC OFF-SHORE WIND NETWORKS

No.	Events of HVDC Offshore Wind Network
1	DC monopolar blocking fault or DC bipolar blocking fault
2	AC mainland grid fault
3	Offshore side transformer fault
4	Wind farm bus fault
...	...

d) "Self-Healing" Strategy

Based on the vulnerability assessment of each event of the HVDC offshore wind network, control actions are needed to steer the system to a secure and less vulnerability operating condition. For a HVDC offshore wind network, there are few connection points to the AC grid, the power injection of a large offshore wind power may create overloading conditions on transmission lines. This issue can be addressed using wind generation curtailment and/or load shedding. For a multi-terminal DC offshore wind farm, DC modulation based VSC converters can shift the power flow pattern to mitigate the overload without having to curtail generation or shed load. The "self-healing" capability identifies the optimal sequence of control actions that can reduce vulnerability, in the preventive or corrective self-healing mode [20].

C. Control centre operations

While fast automatic actions, such as protection and defence systems, are needed to cope with rapidly unfolding phenomena such as faults or short-term instability, general operation of the offshore VPP connected to the mainland grid will be monitored and controlled in adapted control centres. It is therefore necessary to revise all the typical control centre functions, tools, and procedures, in order to adapt them to the new needs brought about by the multi-terminal VPPs. In particular, the control centre Energy Management System (EMS) applications have to be upgraded, to extend the monitoring, analysis, control, and display functions.

The first focus regards monitoring. The VPP must provide to the control centre measurements and information such as the power generated by the wind farms, the power flows through the HVDC grid, converter operation status, and VPP alarms.

In turn, the control centre must communicate with the local,

master control of the VPP for normal and emergency operation functions¹. Normal operation provides the VPP operation settings (e.g. power dispatch strategy, power limits for security reasons, frequency and voltage regulation modes, etc.). Emergency actions consist of fast power reduction (calling for generation trip by the master control) or possibly power shift among converters.

The AC grid security analysis tools have to account for the contingencies coming from, or affecting, the HVDC grid, and the effects of manoeuvres and changes in the DC side on the AC stability.

Under normal control, security assessment functions may evaluate the secure operating region of the HVDC injections, hence the security margins with respect to the actual condition. Conventional generation re-dispatch, used as a preventive control strategy to maintain or restore security, can be complemented by power injection shifting among the terminals of the multi-terminal VPP. While the former action implies resorting to the balancing markets, the latter is virtually for free thus it could have priority.

During emergency control, overload relief may be obtained by an HVDC injection variation. Again, in case of power shift from one converter to another, great care must be paid in order not to jeopardise system security elsewhere, because of the modified flow configuration. To this aim, the power system model considered in security assessment functions must include all the areas in which the HVDC converters are located, which may result into a very large region. This requirement is particularly critical for online applications, because of the dimensionality and jurisdiction issues.

Further remarks concern technical and organisational issues. If the HVDC terminals are located in the same control area, the shift of power from one terminal to another can be regarded as a normal generation re-dispatch within that area. If the onshore terminals belong to different control areas, the power/frequency control is directly affected. This issue lies within the wider context of market and system operation arrangements. In particular, if the onshore terminals are under different TSOs' jurisdiction, specific coordination among TSOs and common operating procedures are needed.

A dedicated control centre may also be envisaged, to support the main one in the multi-terminal VPP operation. This auxiliary control centre would specifically monitor and control the offshore wind generation, analyse the expected production as from the wind forecast, communicate to the main centre any anticipated or actual criticalities, support the security analyses performed in the main centre by focusing on the controlled subsystem: e.g. by carrying out detailed analyses of the HVDC grid and evaluations of the available power shift margins. The exact responsibilities and relationships of the auxiliary control centre with the main centre are to be defined in the overall control system design stage, to guarantee effectiveness by means of a hierarchical,

coordinated structure. The VPP control centre may be even more necessary, if several TSOs are involved in the HVDC grid.

V. CONCLUSIONS

Integrating and operating large amounts of off-shore wind power in the future energy landscape of Europe, strongly relies on the economic and technical feasibility of off-shore HVDC grids which have to be carefully designed .

HVDC technology has proven its efficiency and robustness in the field of long distance transmission of power. It has now to be oriented, via VSC converters with specific architectures from different manufacturers, in the direction of meshed HVDC networks which rise new requirements. The most crucial one as identified today is the detection, selection and clearing of faulty parts on a HVDC grid (see [21]) to keep it operational after a fault has occurred.

Along with the technological under-going progresses, many studies with a power system view for the HVDC grid itself, and for its interconnection with the AC mainland grid still need to be performed.

In the framework of a European project, results achieved on next three years should bring significant insights on:

- 1) the desirable topologies for HVDC networks to meet their wind collector and wind smoother functions on large over-sea areas, while providing the appropriate transmission and interconnection functions and in-feeding optimally the AC mainland grid,
- 2) the design of the protection systems and control laws of these grids to make them operate for different operational conditions and provide appropriate ancillary services to the mainland grid,
- 3) the operation of the hybrid DC / AC power system for normal and disturbed conditions.

This paper gave a comprehensive view of the issues and tasks under progress and to be performed during the project.

VI. REFERENCES

- [1] Joint Pre-feasibility Study by Energinet.dk, Svenska Kraftnät, Vattenfall Europe Transmission, "An Analysis of Offshore Grid Connection at Kriegers Flak in the Baltic Sea", available at : http://www.svk.se/Global/02_Press_Info/090507_Kriegers-Flak-Pre-feasibility-Report-Final-version.pdf
- [2] P. Bresesti, R. Calisti, D. Provenzano, A. Vaiani, and B. Zecca, "Probabilistic model for adequacy evaluation of electric networks with sizeable wind power generation," in *Proc. IEEE PES Power Syst. Conf. Expo.*, Oct. 10–13, 2004, vol. 3, pp. 1324–1328
- [3] G. Migliavacca et al., "Prospects for the transmission planning in Europe towards a sustainable energy future: the REALISEGRID project", accepted at 2010 CIGRE Session, Paris, August 22-27, 2010, paper C1-105
- [4] K.R.W. Bell, D.C. Hill, D. McMillan, F. Li, R.W. Dunn, D.G. Infield and G.W. Ault, "Spatio-Temporal Correlations of Available Wind Power and Impact on Transmission Power Flows", Paper C1-203, *CIGRE Session 2010*, Paris, August 2010.
- [5] Michel Doquet, "Use of a stochastic process to sample wind power curves in planning studies", *IEEE Power Tech 2007*, Lausanne, 2007.
- [6] M. Doquet, R. Gonzalez, S. Lepy, E. Momot, F. Verrier, "A new tool for adequacy reporting of electric systems: ANTARES", Paper C1-305, *CIGRE 2008 Session*, Paris, August 2008.
- [7] Michael P. Bahrman and Brian K. Johnson, "The ABCs of HVDC Transmission Technology", *IEEE Power & Energy Magazine March/April 2007 Vol. 5 No. 2*

¹ Accordingly, different speed channels may be adopted (plus a back-up, local logic to assure VPP operation also in case of loss of communication). All this, in addition to dedicated connections with local or wide area defence systems.

- [8] Fenyan Yang, Yong Chang, "Study on Capacitor Commutated Converter applied in HVDC projects" *Proceedings of the Chinese Society of Electrical Engineering*. Vol. 28, no. 7, pp. 91-96. 5 Mar. 2008
- [9] G. Asplund, K. Eriksson, H. Jiang, J. Lindberg, R. Pålsson, K. Svensson, "DC Transmission Based on Voltage Source Converters." *CIGRE SC 14 Colloquium, No. 14-302, 1998*.
- [10] J. Dorn, H. Hiang, D. Retzmann, "Novel Voltage-Sourced Converters for HVDC and FACTS Applications", Cigre Symposium, November 1-4, 2007, Osaka, Japan
- [11] Liu Y. H., Arrillaga J., Watson N. R., Wood A. R., "Multi-level voltage reinjection VSC HVDC transmission", *The 8th IEE International Conference on AC-DC Power Transmission (ACDC 2006): (28-31 March 2006, Savoy Place, London, UK)*
- [12] Andersen, B.R., Xu, L., Horton, P., Cartwright, P., "Topology for VSC Transmission." *IEEE Power Engineering Journal*, Vol. 16, No 3, pp.142-150, June 2002.
- [13] J. Yang, J. Edward and J. O'Reilly, "Multiterminal DC wind farm collection grid internal fault analysis and protection design," *IEEE Trans. Power Del.* (Accepted)
- [14] L. Wang, K.-H. Wang, W.-J. Lee and Z. Chen, "Power-flow control and stability enhancement of four parallel-operated offshore wind farms using a line-commutated HVDC link," *IEEE Trans. Power Del.*, vol. 25, no. 2, pp. 1190-1202, Apr. 2010.
- [15] A. Reidy and R. Watson, "Comparison of VSC based HVDC and HVAC interconnections to a large offshore wind farm," in *Proc. IEEE Power Engineering Society General Meeting*, vol. 1, pp. 1-8, Jun. 2005.
- [16] J. J. Grainger and W. D. Stevenson, *Power System Analysis*, McGraw-Hill, New York, 1994.
- [17] IEEE Standard C37.113-1999, Guide for Protective Relay Application to Transmission Lines, Sep. 1999.
- [18] R. Wu, S. B. Dewan and G. R. Slemon, "A PWM AC-to DC converters with fixed switching frequency," *IEEE Trans. Ind. App.*, vol. 26, no. 5, pp. 880-885, Aug. 2002.
- [19] N. Acharya, "Security, protection and control of power systems with large-scale wind power penetration," The PhD dissertation, Electrical Engineering of Iowa State University, 2010.
- [20] [7-8] C.-C. Liu, J. Jung, G. T. Heydt, V. Vittal and A. G. Phadke, "The strategic power infrastructure defense (SPID) system. A conceptual design," *IEEE Control Syst. Mag.*, vol. 20, no. 4, pp. 40-52, Aug. 2000
- [21] S. Henry, AM. Denis, P. Panciatici, "Feasibility study of off-shore HVDC grids", IEEE PES GM, Minneapolis, July 2010
- [22] M. Ni, J. D. McCalley, V. Vittal, T. Tayyib, "Online Risk-Based Security Assessment", IEEE Trans. on Power Systems, Vol. 18, No. 1, February 2003
- [23] K. Uhlen, G. H. Kjølle, G. G. Løvås and Ø. Breidablik, "A Probabilistic Security Criterion for Determination of Power Transfer Limits in a Deregulated Environment", Session CIGRE, Paris, 2000
- [24] E. Ciapessoni, D. Cirio, E. Gaglioti, S. Massucco, A. Pitto, F. Silvestro, "Risk evaluation in power system contingency analyses", accepted at 2010 CIGRE Session, Paris, August 22-27, 2010

VII. BIOGRAPHIES

Dr Keith Bell is a Senior Lecturer in the Department of Electronic and Electrical Engineering at the University of Strathclyde in Glasgow in the United Kingdom. He previously spent some years working in the electricity supply industry in the UK and is a Chartered Engineer and a member of The IET, CIGRE Study Committee C1 on "System Development and Economics" and the Power & Energy Society of the IEEE.

Diego Cirio received the M.Sc. degree (1999) and Ph.D. degree (2003) in Electrical Engineering from University of Genoa, Italy. He was with CESI from 2003 to 2006, involved in consultancy activities for the Operations department of the Italian TSO (TERNA, formerly GRTN). Currently he is with "ENEA - Ricerca sul Sistema Elettrico" (ERSE, formerly CESI RICERCA) where he leads the Grid and Infrastructure Security research group. He is involved in national and EU research projects, and he acts as co-Operating Agent of the IEA Implementing Agreement ENARD – Annex IV "Transmission systems". He contributed to the CIGRE WG C4.601. His research interests include power system security assessment, operational risk assessment, wide area monitoring and control, restoration.

Anne-Marie Denis graduated from ENSEEIHT-Toulouse in 1978 and obtained her Ph.D. on Embedded Software Design at LAAS-CNRS Toulouse

in 1981. From 1982 till 2002 she was involved in large scale power system projects developed by EDF-Research and Development Division, contributing as expert and project manager to over 15 international projects on the development of transmission grid interconnection. In 2003 she joined RTE - Research and Development Department. She is currently member of CIGRE, SEE and IEEE, and has contributed to several UCTE and EURELECTRIC working groups.

Lina He received her B.S. and M.S. degrees from Huazhong University of Science and Technology, China, in 2007 and 2009, respectively. She is pursuing the Ph.D. degree in electrical engineering at University College Dublin, Ireland. Her research interests include the protection and defense of HVDC offshore wind network.

Chen-Ching Liu is currently Professor of Power Systems at University College Dublin, Ireland. During 1983-2005, he was on the faculty of the University of Washington, Seattle. He served as Palmer Chair Professor at Iowa State University during 2006-08. His areas of interest include power system security and intelligent system applications to power systems. He is a Fellow of the IEEE.

Gianluigi Migliavacca graduated in Electronic Engineering at the Polytechnic University of Milan. In 1991 he joined the Automation Research Center of ENEL, then CESI and finally CESI Ricerca (now: ERSE), where he leads the Transmission Planning research group within the Power Systems Development department. His research activities deal with mathematical modelling and regulatory issues concerning deregulated electricity markets, cross border trade issues and transmission planning. During 2005 he was consultant at the Italian Regulator about the development of a common energy market in South-East Europe and about congestion management in Central-South Europe. Now, he is the coordinator of the European FP7 research project REALISEGRID (<http://realisegrid.erse-web.it>).

C. L. Moreira obtained the electrical engineering degree (5-years course) in 2003 and the Ph.D. in 2008, both from the Faculty of Engineering of Porto University, Porto, Portugal. Currently, he is Assistant Professor in the Department of Electrical Engineering of the Faculty of Porto University a senior researcher in the Power Systems Unit of Instituto de Engenharia e Sistemas de Computadores do Porto (INESC Porto). His main research interests are focused on power systems dynamics and control, integration of large scale distributed generation, smart grids and smart metering.

Patrick Panciatici graduated from the French Ecole Supérieure d'Electricité in 1984. He joined EDF R&D in 1985, managing in EUROSTAG Project and CSVc project. He joined RTE in 2003 and participated in the creation of the department "Methods and Support". He is the head of a team which develops real time and operational planning tools for RTE, and ensures operational support on the use of these tools. Member of CIGRE, IEEE and SEE. Participation in the ENTSO-E R&D working group.