



Title	Information Gap Decision Theory Based Congestion and Voltage Management in the Presence of Uncertain Wind Power
Authors(s)	Murphy, Conor, Soroudi, Alireza, Keane, Andrew
Publication date	2015-11-29
Publication information	Murphy, Conor, Alireza Soroudi, and Andrew Keane. "Information Gap Decision Theory Based Congestion and Voltage Management in the Presence of Uncertain Wind Power." IEEE, November 29, 2015. https://doi.org/10.1109/TSTE.2015.2497544 .
Publisher	IEEE
Item record/more information	http://hdl.handle.net/10197/7249
Publisher's statement	© 2016 IEEE. Personal use of this material is permitted. Permission from IEEE must be obtained for all other uses, in any current or future media, including reprinting/republishing this material for advertising or promotional purposes, creating new collective works, for resale or redistribution to servers or lists, or reuse of any copyrighted component of this work in other works.
Publisher's version (DOI)	10.1109/TSTE.2015.2497544

Downloaded 2026-05-02 00:30:03

The UCD community has made this article openly available. Please share how this access benefits you. Your story matters! (@ucd_oa)



© Some rights reserved. For more information

Information Gap Decision Theory Based Congestion and Voltage Management in the Presence of Uncertain Wind Power

Conor Murphy, *Student Member, IEEE*, Alireza Soroudi, *Member, IEEE*, and Andrew Keane, *Member, IEEE*

Abstract—The supply of electrical energy is being increasingly sourced from renewable generation. The variability and uncertainty of renewable generation, compared to a dispatchable plant, is a significant dissimilarity of concern to the traditionally reliable and robust power system. This change is driving the power system towards a more flexible entity that carries greater amounts of reserve. For congestion management purposes it is of benefit to know the probable and possible renewable generation dispatch, but to what extent will these variations effect the management of congestion on the system? Reactive power generation from wind generators and demand response flexibility are the decision variables here in a risk averse multi-period AC optimal power flow (OPF) seeking to manage congestion on distribution systems. Information Gap Decision Theory is used to address the variability and uncertainty of renewable generation. In addition, this work considers the natural benefits to the congestion on a system from the over estimation of wind forecast; providing an opportunistic schedule for both demand response nodes and reactive power provision from distributed generation.

Index Terms—Congestion management, Distributed power generation, Information Gap Decision Theory, Optimization, Reactive power.

NOMENCLATURE

$P/Q_{i,t}^L$	Active/ reactive power demand
$P/Q_{i,t}^G$	Active/ reactive power generation
f_b	Base objective function value with no uncertainty
κ_i	Binary variable
Λ_c	Critical limit
$S/P/Q_{ij,t}$	Complex/ active/ reactive power flow between node i and j
$I_{ij,t}$	Current flow between node i and j
ε	Demand flexibility
$P_{i,t}^{D_0}$	Initial active power demand
Λ_o	Opportunistic limit
g_{ij}	Series conductance from node i to node j
b_{ij}	Series susceptance from node i to node j
Γ	Set of all constraints
H	Set of inequality constraints
G	Set of equality constraints
U	Set of uncertain variables

i/j	Set of nodes
g_{si}	Shunt conductance of node i
b_{si}	Shunt susceptance of node i
L/G	Subset of nodes with load/ generation
t	Time period
β	Tolerance level
$\tilde{\rho}$	Uncertain opportunistic radius of uncertainty
$\hat{\rho}$	Uncertain robust radius of uncertainty
Ψ	Vector of uncertain input parameters
$\theta_{ij,t}$	Voltage angle difference from node i to node j
$V_{i,t}$	Voltage magnitude of node i

I. INTRODUCTION

AS global efforts to reduce carbon emissions continue, so too will the interest in the installation of renewable generation sources in power systems. The benefits of these installations are numerous when correctly managed; asset upgrades are deferred [1], losses are reduced [2] and as thermal plants are displaced, carbon emissions are reduced [3]. However, the uptake of distributed generation (DG) challenges the traditional operation of the power system [4]; causing voltage rise [5] and thermal constraint breaches [6] as well as stability issues at large penetration levels [7]. These problems are manifested due to the nature of the series resistance and reactance of the distribution lines. The reactance to resistance (X/R) ratio of these lines is significantly lower in contrast to their counterparts on the transmission system [8], most notably causing voltage rise with active power injections.

Using the methodology of Information Gap Decision Theory (IGDT) in an AC optimal power flow (OPF) setting, this work seeks to coordinate the flexible capabilities of DG and demand response (DR) nodes to manage the congestion on a section of distribution network allowing for the uncertainty of wind generation. The proposed approach determines a quantitative solution of wind generation forecast error to satisfy a level of tolerance for congestion on the system. Utilizing an optimal schedule for the flexible components on the network ensures that satisfactory congestion and voltage management in the presence of uncertainty is obtained.

In the case of wind generation, the uncertainty and variability surrounding its production are onerous to manage. Managing active and reactive power system flows in the presence of variable resources will continue to require considerable analysis, in particular as penetration levels increase into the future. Numerous solutions have been proposed to manage congestion

This work was conducted in the Electricity Research Centre, University College Dublin, Ireland, which is supported by the Electricity Research Centre's Industry Affiliates Programme (<http://erc.ucd.ie/industry/>). This material is based upon works supported by the Science Foundation Ireland and is funded through the SEES Cluster, under Grant No. SFI/09/SRC/E1780. The opinions, findings and conclusions or recommendations expressed in this material are those of the author(s) and do not necessarily reflect the views of the Science Foundation Ireland.

as it becomes apparent on a section of network. A risk based AC OPF approach is used in [9] to assess the curtailment of wind to manage network flows. [10] incorporates probabilistic constraints into a DC OPF to make the power system robust against uncertain demand and generation. FACTS devices have been shown to be used as a means of providing reactive power to alter system flows and ease congestion [11]. The authors of [12] develop a technique to relieve transmission-line over-loads based on reactive power control of synchronous machines. In [13], the rescheduling of the active and reactive power of conventional synchronous generators in order to alleviate a congested section within a test system is considered. The analysis is undertaken on the transmission system where it can be assumed that only active power injections affect voltage angle and reactive power injections will only contribute to a change in voltage magnitude. The coordinated dispatch of reactive power on a distribution system, as in [14], affects both the magnitude and phase of the voltages on a network; informing the solution to optimally allocate reactive power from DG to manage congestion.

The uncertain and variable nature of wind requires a unique type of analysis and many techniques exist that incorporate the uncertainties of parameters. These techniques require the historic behaviour of the uncertainties to be characterized, i.e. through the use of a probability density function. Broadly speaking, when dealing with an uncertain parameter, there are three methods that look to characterize the uncertainty and perform deterministic analysis. These methods are probabilistic methods, possibilistic methods and a hybrid method; a combination of probabilistic and possibilistic [15], [16]. A drawback of these methods is their ability to perform with severe uncertainty. As an alternative to the requirement of characterizing the probability of wind generation as a parameter, this work uses information gap decision theory (IGDT) [17], a non-probabilistic quantification of uncertainty. IGDT has been used in many fields of research, in [18] to assess the management of timber production and in [19] for the planning of water resources. This approach is also applicable to power system analysis [20-23] especially under severe uncertainty.

Utilizing IGDT, this work seeks to protect the flexible decision variables of DG reactive power provision and DR active power in an AC OPF solution against unknown risk, allowing for the uncertainty and variability of wind generation. The present work seeks to determine the flexible dispatch of DR nodes and DG reactive power provision ahead of time, such as to maximize the robustness in the case the wind forecast is under estimated and to minimize the opportunity function in the case the wind forecast is over estimated. Using these flexible components of active power and reactive power on the network, a quantitative answer can be determined of how poorly predicted the wind forecast may be, while still adhering to the tolerance set by the SO.

Section II describes the methods used in this work, detailing the problem formulation and the uncertainty modeling tool. Section III describes the test network and Section IV discusses congestion management with DG. Section V provides the results of the IGDT analysis and conclusions are drawn in Section VI.

II. METHODOLOGY

This work uses IGDT based uncertainty modeling of wind generation to manage congestion. Underpinning this technique are the constraints and decision variables of an AC OPF.

A. IGDT based Uncertainty Modeling

In this paper, an IGDT based model [17] is proposed to handle the uncertainty of wind power generation. The proposed method does not need any probability density function. It is exact and computationally efficient. The general optimization problem is expressed in (1-3), where the constraints of an AC OPF formulation reside.

$$\min_X f(X, \Psi) \quad (1)$$

$$\mathbf{H}_n(X, \Psi) \leq 0, n \in \Gamma_{ineq} \quad (2)$$

$$\mathbf{G}_m(X, \Psi) = 0, m \in \Gamma_{eq} \quad (3)$$

where, Γ is the set of all constraints, Ψ is the vector of uncertain input parameters and \mathbf{H} and \mathbf{G} are the set of inequalities and equalities for the variables X . There are two outcomes of interest when using IGDT; a value of robustness (4-8) which enables a risk-averse, conservative approach to dealing with the uncertainty, and an opportunistic value (9-13) which reveals the speculative, risk seeker approach. In this work, the IGDT based AC OPF is formulated as:

$$\max_X \hat{\varrho}(X, \Psi) \quad (4)$$

$$\mathbf{H}_n(X, \Psi) \leq 0, n \in \Gamma_{ineq} \quad (5)$$

$$\mathbf{G}_m(X, \Psi) = 0, m \in \Gamma_{eq} \quad (6)$$

$$\hat{\varrho} = \{\max_{\Psi} \varrho | f(X, \Psi) \leq \Lambda_c = (1 + \beta_c) f_b\} \quad (7)$$

$$\Psi \in U(\bar{\Psi}, \varrho) = \left\{ \Psi : \left| \frac{\Psi - \bar{\Psi}}{\bar{\Psi}} \right| \leq \varrho \right\} \quad (8)$$

where, Λ_c , is the critical limit which is to be satisfied when the realized values are worse than the forecasted ones, $\bar{\Psi}$ is the forecasted value of Ψ the uncertain parameter, f_b is the value of base objective function when no uncertainty exists, β_c is the tolerance level specified by the decision maker and ϱ is the unknown radius of uncertainty.

$$\min_X \check{\varrho}(X, \Psi) \quad (9)$$

$$\mathbf{H}_n(X, \Psi) \leq 0, n \in \Gamma_{ineq} \quad (10)$$

$$\mathbf{G}_m(X, \Psi) = 0, m \in \Gamma_{eq} \quad (11)$$

$$\check{\varrho} = \{\min_{\Psi} \varrho | f(X, \Psi) \leq \Lambda_o = (1 - \beta_o) f_b\} \quad (12)$$

$$\Psi \in U(\bar{\Psi}, \varrho) = \left\{ \Psi : \left| \frac{\Psi - \bar{\Psi}}{\bar{\Psi}} \right| \leq \varrho \right\} \quad (13)$$

where, Λ_o is the opportunistic limit which is hoped to be achieved when the realized values are a reduced version of the forecasted ones and β_o is the anticipated level of improvement specified by the decision maker.

B. AC Optimal Power Flow

Featured in the set of all constraints, Γ , of the IGDT model is the formulation of an AC OPF. In OPF problems generator node quantities, active and reactive power, bus voltage and other power system parameters are independent variables with defined ranges of stable operation. The OPF, in finding the optimal solution, seeks to determine these values to minimize or maximize a chosen objective function.

1) *Objective Function*: The objective function (14) aims to minimize the sum of power flow in all lines of the network, across multiple periods, t .

$$\min : \sum_{i,j} S_{ij,t} \quad \forall t \quad (14)$$

where $S_{ij,t}$ is the complex power flow in a line connecting bus i to bus j . The reactive power from DG is the sole control variable used by the AC OPF tool, through (14) to achieve the objective. With the objective of minimizing the complex power flow the intention is to ease congestion and better manage the thermal limits of the network.

2) *Constraint Equations*: Constraint equations governing active power (15) and reactive power (16) flow in the AC OPF tool, are derived from the π equivalent circuit for medium length transmission lines.

$$P_{ij} = V_i^2(g_{si} + g_{ij}) - V_i V_j (g_{ij} \cos \theta_{ij} + b_{ij} \sin \theta_{ij}) \quad (15)$$

$$Q_{ij} = -V_i^2(b_{si} + b_{ij}) - V_i V_j (g_{ij} \sin \theta_{ij} - b_{ij} \cos \theta_{ij}) \quad (16)$$

As is typical for an OPF, Kirchhoff's Current Law is adhered to, constraining the summation of active power injections (17) for any node on the power system to zero. The same is true for the summation of reactive power injections (18) for any node on the power system.

$$P_{i,t}^{net} = -P_{i,t}^L + P_{i,t}^G \quad (17)$$

$$Q_{i,t}^{net} = -Q_{i,t}^L + Q_{i,t}^G \quad (18)$$

Equating the active power and reactive power flow on the lines of the network to the net power flow found from (17) and (18) for a connected node, gives (19) and (20).

$$P_{i,t}^{net} = \sum_j P_{ij} \quad (19)$$

$$Q_{i,t}^{net} = \sum_j Q_{ij} \quad (20)$$

The node voltage magnitudes (21) are bound between an upper and lower limit.

$$V_{i,t}^- \leq V_{i,t} \leq V_{i,t}^+ \quad (21)$$

All lines are to be operated below their rated current limit (22).

$$I_{ij,t} \leq I_{ij,t}^+ \quad (22)$$

3) *Decision Variables*: In the main body of this work the decision variable to manage congestion is the provision of reactive power from distributed generation units, $Q_{i,t}^G$, constrained between upper and lower machine limits. The reactive power capability chart of the DG units, illustrated in Fig. 1, closely mapping that of modern variable speed wind turbines is modeled with two symmetric sigmoid functions (23) and (24) for the lower and upper limits respectively. For active power generation, $P_{i,t}^G$, above 15% of the maximum capability, an inductive and capacitive limit for reactive power of 0.5 times the maximum active power generation is enforced. For

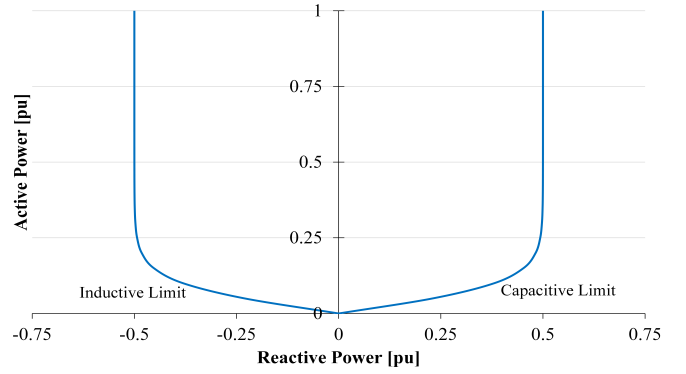

Figure 1. Reactive power capability chart of distributed generation

active power generation less than 15% of maximum capability, the allowable range of operation is constrained by symmetric sigmoid functions, as described in [23].

$$Q_{i,t}^{G-} \geq \left(\frac{-0.5}{1 + e^{20 \times P_{i,t}^G}} \right) \quad (23)$$

$$Q_{i,t}^{G+} \leq \left(\frac{+0.5}{1 + e^{20 \times P_{i,t}^G}} \right) \quad (24)$$

The energy provided by a DR load, across multiple periods, is constrained to equal a scheduled amount (25). Within this time period the power delivered by a DR load, $P_{i,t}^{L_{new}}$, can vary from the initial schedule, $P_{i,t}^{L_0}$. In this work the demand flexibility parameter, ε , varies from 0-30% in 10% increments limiting the amount by which the active power of the load can vary (26).

$$\sum_t P_{i,t}^{L_0} = \sum_t P_{i,t}^{L_{new}} \quad (25)$$

$$(1 - \varepsilon) P_{i,t}^{L_0} \leq P_{i,t}^{L_{new}} \leq (1 + \varepsilon) P_{i,t}^{L_0} \quad (26)$$

The power factor of the load is maintained such that the reactive power contribution from the DR node is kept to the same ratio.

III. TEST NETWORK

The chosen test network under examination is a 201 node 10 kV distribution network. The technical data of this network, including the line rating and series and shunt admittance information, is provided in [24]. The radial network topology, illustrated in Fig. 2, contains 168 load centers and 200 conductors. Notional wind has been allocated to the network where a single day with half hourly resolution is modeled from historic wind and demand data. The connecting nodes and capacity information for DG are provided in Appendix A.

The method of allocating the nodes which are most influential to the objective of this work (14), is formulated in Appendix B. The DR allocation method returns, in ranked order, the most influential nodes in the system where providing flexibility of the demand would have most impact on the objective function (14). The CONOPT solver of GAMS [25] is used to solve the non-linear power flow problem and IGDT modeling. The mixed integer non linear program of the DR allocation method uses the DICOPT solver of GAMS [25].

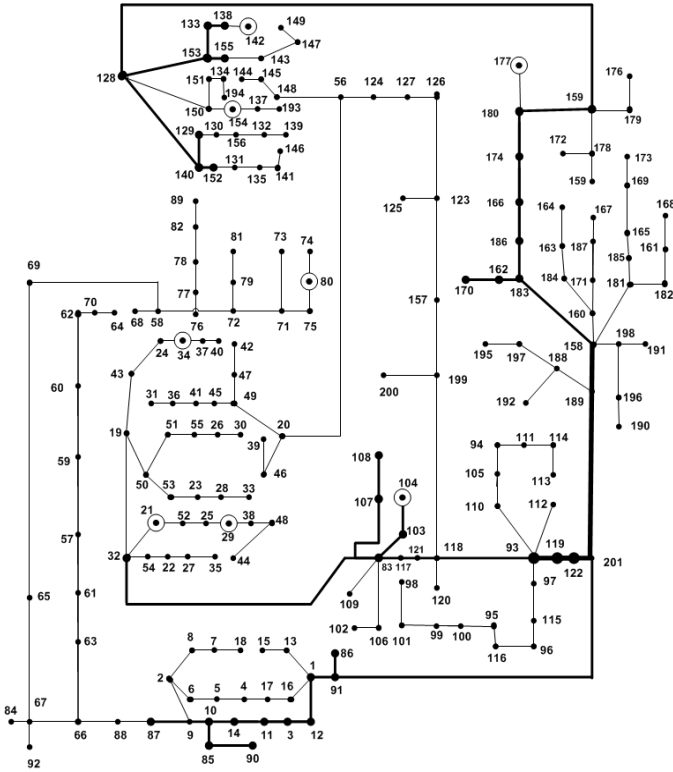

Figure 2. 201 node distribution network with location of DG marked in small circles

IV. CONGESTION MANAGEMENT WITH DISTRIBUTED GENERATION

To highlight the impact the optimal provision of reactive power resources from DG has in managing system flows, a one-off case study power flow scenario is considered. This involves maintaining the DG units to a static set point of unity power factor, chosen so as neither the injection or absorption of reactive power from DG influences the complex power flow on the network. In this initial simulation there is no flexibility provided by the DR nodes and at this point no uncertainty is considered in the generation from wind. The AC OPF formulation (1-3) is solved obtaining the optimal provision of reactive power from DG in this deterministic environment. This is done to obtain the optimal base objective function value, f_b , needed in later analysis, and to contrast this solution to the unity power factor solution of the case study.

As an example of the reduction in complex power flow possible, Fig. 3 illustrates the complex power flow along one line, Line 01_91, for both the case study and the results of the AC OPF. As seen, the peak flow along this line reduces from 0.23 MVA in the case study power flow to 0.125 MVA with the optimal provision of reactive power from DG units. System wide, the summation of complex power flows comes to 9.9 MVA; utilizing the reactive power from DG in a coordinated and optimal manner results in a 65.66% reduction in complex power flows, achieving 3.4 MVA. Another feature from the optimal provision of reactive power is the effect of reducing the active power losses on the network, here a 33.7% reduction is recorded on the system; reducing from 0.285 to 0.189 MWh.

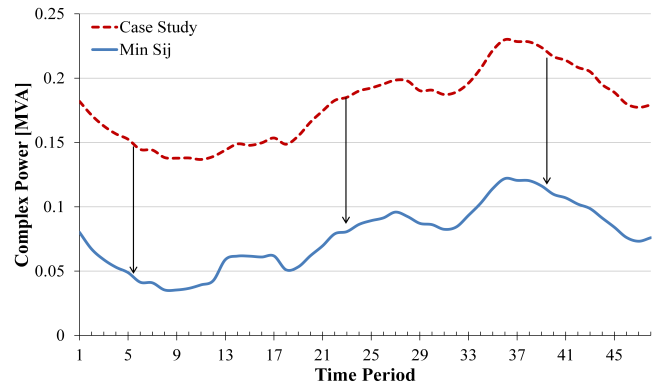

Figure 3. Line 01_91 - Reduction in complex power flow from the case study

The AC OPF simulation (1-3) is repeated for increasing amounts of demand flexibility, ε , from 0-30% in 10% intervals. The DR nodes were placed in accordance with the methodology of Appendix B. Table I provides the further decrease in f_b , the base objective function value, for increasing demand flexibilities, alongside the congestion index of the case study.

Table I
BASE OBJECTIVE FUNCTION VALUE WITH INCREASING DR

ε [%]	Case Study	0	10	20	30
f_b [MVA]	9.90	3.40	3.34	3.31	3.29

These results highlight that the choice of reactive power dispatch of DG and active power drawn by flexible DR nodes significantly impacts the complex power flow and by extension, the current flow and thermal congestion on a distribution network. This test network consists of a radial distribution network with low X/R ratios, varying from 1 to 0.33 depending on the length and type of cable considered. A high interdependence exists between voltage angle and magnitude and complex power injections, brought on by lower X/R ratios. As both the voltage angle and magnitude, as well as the flow of active and reactive power, contribute to current flow, the optimal reactive power provision from DG and scheduling of active power from DR, developed here, is a potentially effective means of managing congestion on such a network.

This ACOPF method assume that to alleviate congestion in a network, the generation of active power is a known parameter in the formulation. The uncertainty of this parameter is now considered, as this work seeks to determine whether the decision variables of the DG units and DR nodes can be set to protect these optimal congestion management solutions when the wind generation is underestimated. In addition, the choice of decision variables is investigated that would capitalize on the over estimation of wind to achieve the best results under the circumstance.

V. IGD AC OPF APPROACH

To account for the uncertainty of wind power generation, flexible DR nodes and reactive power provision from DG vary to determine the robustness and opportunities for multiple

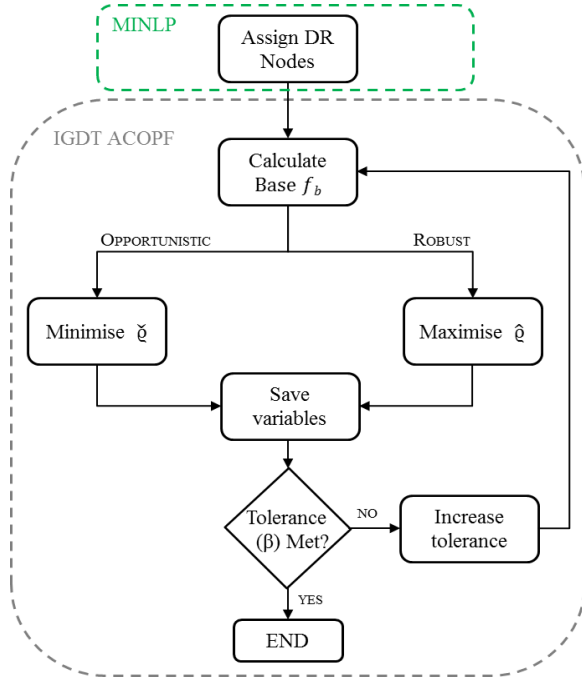

Figure 4. Flow chart of IGDT ACOPF method for a given level of demand response

tolerance levels. As stated, the realization of achieving the results of the AC OPF, requires the perfect forecast of wind generation. In addition, the multi-period AC OPF approach implies the use of a smart-grid fit with communication links to provide for the decision making of a central global solution. As an alternative to perfect knowledge and dependence on communication links, this work uses IGDT to assess what the flexible demand and reactive power provision from DG can do to achieve an outcome that is acceptable to the system operator (SO).

From the congestion management with DG simulations, it is observed that optimally, a minimal value of 3.4 MVA is achievable for the congestion index. This is a significant decrease from the case study, presented in Section IV, whereby static set points are adopted for the provision of reactive power from DG. The present work increases the congestion index value to 5.1 MVA and reduces it to 2.6 MVA in small increments while the uncertainty gap is obtained for both the robustness approach (4-8) and, separately, the opportunistic approach (9-13). This signifies a respective 50% increase and 25% decrease in the tolerance of the SO when looking to manage congestion on the system. The uncertainty gap in this case is the underestimation and overestimation of wind generation at the DG nodes. Fig. 4 illustrates a flow chart in use for the following sections. The calculation of the half hourly daily schedules and uncertainties for a specified tolerance takes on average 5.8 s on an Intel® Core™ i7-3770 processor with a CPU at 3.4 GHz.

A. Robustness Function

The IGDT robust approach maximizes the under estimation of wind forecast (4-8) to limit the natural increase of the

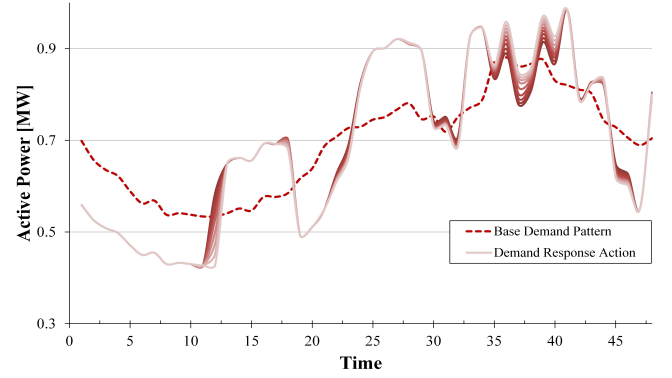

Figure 5. Risk averse demand response actions (node 142) shown with time for a demand flexibility, ϵ , of 30%

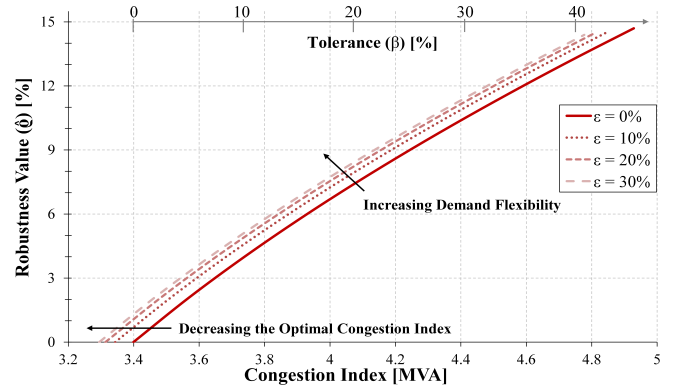

Figure 6. Robustness (\hat{q}) vs congestion index with increasing demand flexibility (ϵ)

objective function value. The choice of decision variables for a DR node on the network can be examined, maximizing the robustness of the model, through the uncertain parameter Ψ , with increased demand flexibility, ϵ . Fig. 5 shows the DR action of the most influential node on the system, node 142, compared to its scheduled base demand profile (dashed line). The figure shows ten demand curves, one for each tolerance level β_c . Captured in this plot are the changes in the decision variable as the tolerance level increases by 50%, or by 1.7 MVA, and the robustness of the model is maximized against wind uncertainty, for 30% DR flexibility.

Fig. 6 highlights the impact increasing the demand flexibility has on reducing the congestion index. Logically, as greater flexibility is provided by the DR nodes, a more minimal solution is obtained. The robustness value is maximized as the tolerance level, β_c , is increased from 0-50% for four levels of demand flexibilities, ϵ . For example in the case where a 21% tolerance is investigated with 10% demand flexibilities included, the wind generation underestimation is maximized as the congestion index is constrained to an upper limit of 4.04 MVA or a 21% increase from the base objective function value of 3.34 MVA provided in Table I. The proximity of these curves is of interest. For this selection of DG, and most influential DR nodes, a 10% increase in demand flexibility achieves a 1% increase in the robustness against uncertainty of active power wind generation.

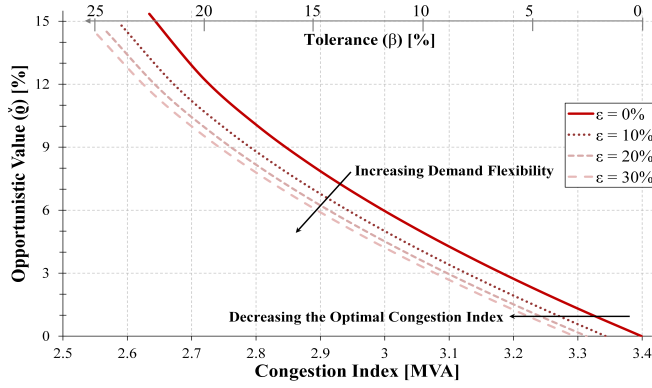

Figure 7. Opportunistic value (\hat{q}) vs congestion index with increasing demand flexibility (ε)

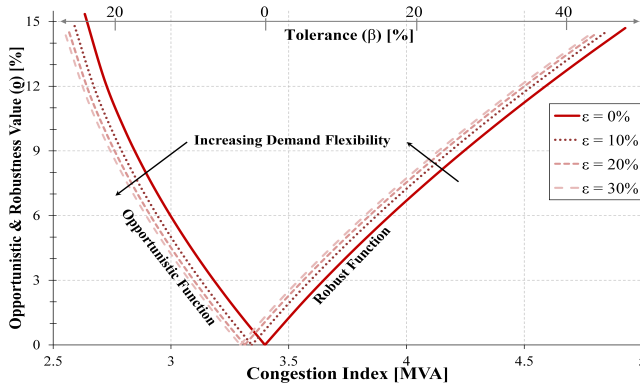

Figure 8. Opportunistic (\hat{q}) and Robustness Values (\hat{q}) vs congestion index with increasing demand flexibility (ε)

B. Opportunistic Function

The IGDT opportunistic approach minimizes the over estimation of wind forecast (9-13) to capitalize on the natural decrease of the objective function value. In addition, a dispatch for the DR nodes and the reactive power from the DG units is calculated to minimize the uncertain parameter, Ψ . Increasing the demand flexibility here reduces the congestion index, as seen in Fig. 7. The tolerance level, β_o , is increased from 0-25% for four levels of demand response flexibilities, ε . For example in the case where a 16% tolerance is investigated with 20% demand flexibilities included, the wind generation overestimation is minimized as the congestion index is constrained to a lower limit of 2.78 MVA or a 16% decrease from the base objective function value of 3.31 MVA provided in Table I. As with the robustness function, for this selection of DG and most influential DR nodes, a 10% increase in demand flexibility achieves a 1% decrease to the opportunistic value against uncertainty of active power wind generation.

For clarity, the results from the robustness function and the opportunistic function are presented in a combined illustration, plotted against the congestion index with increasing demand flexibility in Fig. 8. Applying this analysis to the findings from the day simulation with half hourly resolution; with a forecast error of 5% of over estimated wind, using the profile of set points generated for DG and DR nodes, a minimum

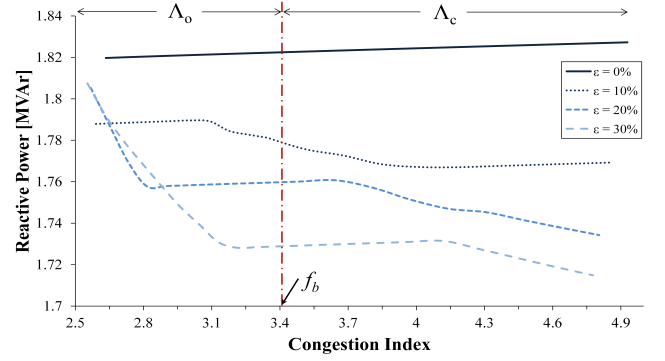

Figure 9. Optimal reactive power provision of DG at node 104 with increasing uncertainty and increased demand flexibility (ε) for critical limit Λ_c and opportunistic limit Λ_o

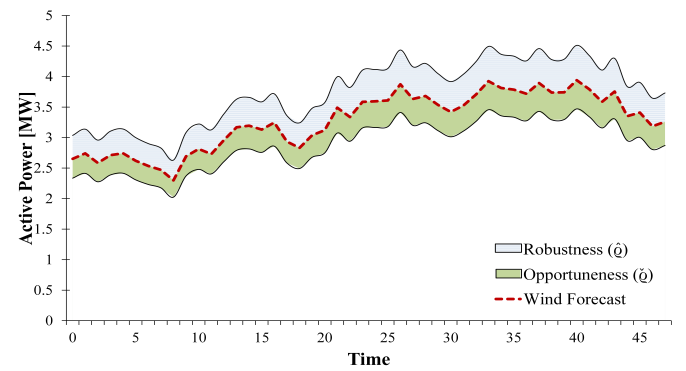

Figure 10. Wind profile of DG at node 177 shown with critical limit Λ_c and opportunistic limit Λ_o

reduction of approximately 9% in the objective function value, f_b , would be expected. On the other hand for the SO wishing to maintain a robust solution, a 5% under estimation of wind production would limit the increase in the congestion index, f_b , to approximately 13% or 3.85 MVA, if the set points generated for the DG and DR nodes were used.

C. Congestion Management with IGDT AC OPF

The IGDT approach provides the SO with values for the decision variables on the network for a given day to protect against unknown risk of under estimated wind forecast, but also to venture the additional benefit that could be obtained with an over estimated wind forecast. Fig. 9 shows both options for the uncertainty of wind, providing an insight to the reactive power set points of the DG unit located at node 104, for a single moment in time.

With no demand flexibility on the network, $\varepsilon = 0\%$, a linear trend features in the operating points of this DG as the tolerance level, β , increases away from the optimal set point for both the robust (right) and opportunistic (left) case. A more convoluted arrangement is evident as demand flexibility gradually increases, allowing for a decrease in the congestion index. For the robust case, decreasing amounts of reactive power were required as more DR becomes available and the tolerance level is increasingly relaxed. On the other hand, in

the opportunistic case, as the tolerance level is increased, the trend in the reactive power provision seems to converge to a single operating point, suggesting that an optimal set point exists independent of the level of demand flexibility.

Allowing for 20% flexibility of DR and the optimal coordination of reactive power from DG units, Fig. 10 shows the uncertainty of wind power generation that can be accommodated on the network. Illustrated, is the upper and lower bounds of uncertainty that were obtained at 50% increase and 25% decrease in the tolerance of congestion index, allowing for approximately 15% of uncertainty of wind forecast for the period considered.

D. Method Verification

To test the robustness of the method, a sample value of tolerance, β_c , of 30% is now considered. With a demand flexibility value, ε , of 20% the scheduled profiles from DR nodes and reactive power provisions from DG units, found from the IGDT AC OPF simulations, are allocated across the network to provide a robust solution in the case of under estimated wind forecast values. 1000 randomly simulated uncertainty values, normally distributed, are tested for between the upper and lower bounds obtained from the IGDT robust simulations. The results of the IGDT suggest an upper limit of 10.32% wind forecast error could be accommodated, such as to limit the congestion index value in the optimal base case, f_b , (3.31 MVA) to a 30% increase (Λ_c). The simulation is a success if the congestion index value remains under 4.308 MVA for all 1000 simulations. As seen in Fig. 11 (a), the congestion index never rises above the critical limit Λ_c . Dispatching the reactive power of the DG units and utilizing the DR nodes according to the solution of the IGDT, has protected the optimal objective function value of the AC OPF within a certain tolerance level. The optimal value, f_b , is the result of the perfect coordination in ideal communication. With uncertainty in the wind generation accounted for and no coordination or communications assumed, the congestion index remains well below the case study of unity power factor (9.90MVA), due to the optimal utilization of the flexible decision variables on the network.

Fig. 11 (b) shows the additional benefits to the congestion index brought about by over estimating the wind forecast. The DG reactive power provision and DR active power schedules found from the opportunistic approach of the IGDT method are tested with a tolerance level, β_c of 10% and a demand flexibility value, ε , of 20%. The IGDT opportunistic approach suggests that, for a wind power over estimation of 4.9% and above the scheduled profiles will guarantee a congestion index value of at least 2.96 MVA (Λ_o), or a 10% reduction from the optimal base case value, f_b . In the normally distributed 1000 randomly generated uncertainty values tested, the congestion index reliably fell below the optimal base case value, f_b , of 3.31 MVA always providing a guaranteed opportunistic limit, Λ_o , up to 2.96 MVA, as seen in Fig. 11 (b).

1) *Comparison to a Probabilistic Approach:* Considering the advantages of IGDT over a probabilistic approach in the context of this work, the IGDT method does not require a

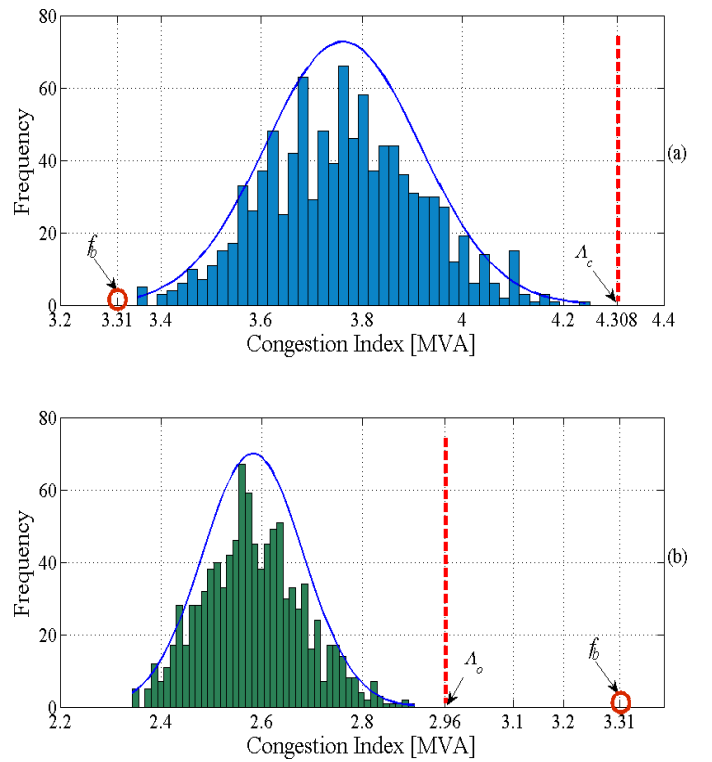

Figure 11. Probability density functions of randomly simulated uncertainty scenarios for 30% β_c (a) and 10% β_o (b) at 20% demand flexibility, ε , shown with the base objective function value f_b

probability density function to account for the uncertainty of wind generation. Furthermore, in stochastic methods every additional scenario increases, in direct proportion, the number of variables considered; thereby increasing the dimension of the problem to be solved. In contrast, the IGDT method does not add another dimension to the existing variables.

The IGDT approach determines the maximum wind forecast error allowed for by the flexible components on a network such as to fall within a specified tolerance of the optimal and deterministic solution. In this work a schedule is obtained for the flexible components that guarantee to be close to optimal presuming the realized wind generation remains within certain determinable bounds. The dispatch obtained from a probabilistic approach is only optimal and valid for that scenario set and grants little insight as to what may occur in other scenarios. If the realized wind generation is outside the forecast amount, no definitive assurance can be made that the assigned control variables will result in an acceptable congestion index that falls within a tolerance of the deterministic and optimal solution.

Assessing the 1000 samples of Fig. 11 (a) which are representative of a probabilistic approach; the conclusion to be drawn is that an expected value of 3.75 MVA is obtained. Likewise, an expected value of 2.57 MVA is obtained in the 1000 scenarios generated in Fig. 11 (b), if assessed from a probabilistic approach. However, in other scenarios the realized value for the congestion index remains uncertain. Herein lies the strength of the IGDT method, providing an optimal schedule that returns a tolerable congestion index while allowing for extreme uncertainty.

VI. CONCLUSION

This paper presents a risk averse and opportunity endorsed congestion management methodology using reactive power of wind turbines as well as DR to protect the optimal coordination of a base case AC OPF method. The objective is defined as maximizing the robustness of the congestion index against the uncertain wind power generation using information gap decision theory. In addition, the opportunity of outperforming the optimal base case AC OPF is also presented for an SO that conservatively over estimates the generation from wind. In this opportunistic case the objective is defined as maximizing the opportunity of the congestion index against uncertain wind power generation. The proposed approach is tested on a practical 201-bus network to demonstrate its applicability. The proposed technique is exact and does not add a large computational time, taking on average 5.8 s, which makes it practical for large scale case studies.

Undoubtedly, the shortcoming of the AC OPF approach is its deterministic nature, whereby all parameters are assumed known. The IGDT method allows for the severe uncertainty of parameters to be modeled, providing the worst case scenario with an acceptable solution. This work has shown that, for an acceptable amount of tolerance, the coordinated reactive power dispatch of DG and active power schedule of optimally sited DR nodes can be used to ease congestion and manage power flow on a section of distribution network, accommodating the uncertain nature of wind power generation. With up to a 15% forecast error in wind power, the scheduled provision of reactive power and DR active power nodes, found here, ensured that the congestion index was at all times within the allowable tolerance level, but also more favorable than that obtained in a static set point operation case.

APPENDIX A

DISTRIBUTED GENERATION LOCATION AND CAPACITY

The installed capacity and location of DG units allocated on the test network of Fig. 2 are provided in Table II.

Table II
DISTRIBUTED GENERATION LOCATION AND CAPACITY

Node	21	29	34	80	104	142	154	177
Capacity [MW]	6.5	1.5	2	5	6	3	4	7

APPENDIX B

METHOD OF ALLOCATION OF DEMAND RESPONSE

The allocation of DR nodes was solved using a mixed integer non linear program. As the combination of the most influential nodes to be included for DR is to be determined, the decision to include one node over another is discrete; therefore, a mixed integer problem is formulated. In this analysis, the constraint (26) limiting the contribution of a DR node to an upper limit, ε , is modified to include a binary variable, κ_i , as per (27). The merit order for the DR nodes is obtained by solving (28) and modifying the number of nodes, N , to be allocated. The objective function (14) is unmodified, providing the optimal choice of nodes that are most influential

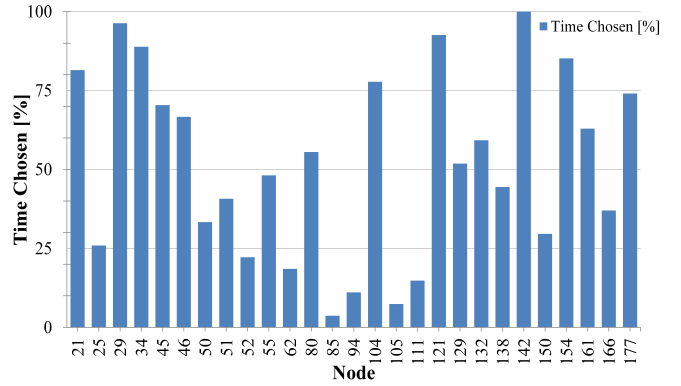

Figure 12. Most influential DR nodes in minimizing the base objective function value, f_b , for a demand flexibility, ε , of 20%

in minimizing the complex power flow on the network across the periods in question.

$$(1 - \varepsilon\kappa_i)P_{i,t}^{L_0} \leq P_{i,t}^{L_{new}} \leq (1 + \varepsilon\kappa_i)P_{i,t}^{L_0} \quad (27)$$

$$\sum \kappa_i = 1, 2 \dots N \quad (28)$$

Fig. 12 shows the allocation of DR nodes, as seen, the most influential node is 142 and the least important node is 85. Notably, the nodes that host the largest demand weren't necessarily considered most influential. There are nodes in the system drawing a smaller amount of load that were ranked above large load centers. This allocation is dependent on a number of factors, namely; the allocation of DG, the X/R ratios of the network, the network topology, thermal ratings of lines, the amount of load and the proximity to heavily loaded lines. All of these factors are intuitively captured in the formulation of the AC OPF.

REFERENCES

- [1] M. F. Shaaban, Y. M. Atwa, and E. F. El-Saadany, "DG allocation for benefit maximization in distribution networks," *Power Systems, IEEE Transactions on*, vol. 28, no. 2, pp. 639–649, 2013.
- [2] L. F. Ochoa and G. P. Harrison, "Minimizing Energy Losses: Optimal Accommodation and Smart Operation of Renewable Distributed Generation," *IEEE Trans. Power Syst.*, vol. 26, no. 1, pp. 198–205, 2011.
- [3] E. Denny and M. O'Malley, "Wind generation, power system operation, and emissions reduction," *Power Systems, IEEE Transactions on*, vol. 21, no. 1, pp. 341–347, 2006.
- [4] M. H. Bollen, *Integration of Distributed Generation in the Power System*, IEEE Press, Ed. Wiley, 2011.
- [5] C. L. Masters, "Voltage rise: the big issue when connecting embedded generation to long 11 kV overhead lines," *Power Engineering Journal*, vol. 16, no. 1, pp. 5–12, 2002.
- [6] T. Sansawatt, L. F. Ochoa, and G. P. Harrison, "Smart Decentralized Control of DG for Voltage and Thermal Constraint Management," *Power Systems, IEEE Transactions on*, vol. 27, no. 3, pp. 1637–1645, 2012.
- [7] E. Vittal, M. O'Malley, and A. Keane, "A Steady-State Voltage Stability Analysis of Power Systems With High Penetrations of Wind," *Power Systems, IEEE Transactions on*, vol. 25, no. 1, pp. 433–442, 2010.
- [8] R. D. Evans and H. K. Sels, "Power limitations of transmission systems," *A.I.E.E., Journal of the*, vol. 43, no. 1, pp. 45–51, 1924.
- [9] S. W. Alnaser and L. F. Ochoa, "Advanced Network Management Systems: A Risk-Based AC OPF Approach," *Power Systems, IEEE Transactions on*, vol. 30, no. 1, pp. 409–418, 2015.

- [10] H. Yu and W. D. Rosehart, "An Optimal Power Flow Algorithm to Achieve Robust Operation Considering Load and Renewable Generation Uncertainties," *Power Systems, IEEE Transactions on*, vol. 27, no. 4, pp. 1808–1817, 2012.
- [11] X. P. Zhang, B. Chong, K. R. Godfrey, L. Yao, M. Bazargan, and L. Schmitt, "Management of Congestion Costs Utilizing FACTS Controllers in a Bilateral Electricity Market Environment," in *Power Tech, 2007 IEEE Lausanne, 2007*, pp. 1244–1249.
- [12] E. S. Hoji, A. Padilha-Feltrin, and J. Contreras, "Reactive Control for Transmission Overload Relief Based on Sensitivity Analysis and Cooperative Game Theory," *Power Systems, IEEE Transactions on*, vol. 27, no. 3, pp. 1192–1203, 2012.
- [13] A. Kumar, S. C. Srivastava, and S. N. Singh, "A zonal congestion management approach using real and reactive power rescheduling," *IEEE Trans. Power Syst.*, vol. 19, no. 1, pp. 554–562, 2004.
- [14] C. Murphy and A. Keane, "Optimisation of wind farm reactive power for congestion management," in *PowerTech, 2013 IEEE Grenoble, 2013*, pp. 1–6.
- [15] A. Soroudi, "Possibilistic-scenario model for DG impact assessment on distribution networks in an uncertain environment," *Power Systems, IEEE Transactions on*, vol. 27, no. 3, pp. 1283–1293, 2012.
- [16] A. Soroudi and T. Amraee, "Decision making under uncertainty in energy systems: State of the art," *Renewable and Sustainable Energy Reviews*, vol. 28, no. 0, pp. 376–384, Dec. 2013. [Online]. Available: <http://www.sciencedirect.com/science/article/pii/S1364032113005790>
- [17] Y. Ben-Haim, *Info-gap decision theory: decisions under severe uncertainty*. Academic Press, 2006.
- [18] M. A. McCarthy and D. B. Lindenmayer, "Info-gap decision theory for assessing the management of catchments for timber production and urban water supply," *Environmental management*, vol. 39, no. 4, pp. 553–562, 2007.
- [19] B. Korteling, S. Dessai, and Z. Kapelan, "Using information-gap decision theory for water resources planning under severe uncertainty," *Water resources management*, vol. 27, no. 4, pp. 1149–1172, 2013.
- [20] K. Chen, W. Wu, B. Zhang, and H. Sun, "Robust Restoration Decision-Making Model for Distribution Networks Based on Information Gap Decision Theory," *Smart Grid, IEEE Transactions on*, vol. 6, no. 2, pp. 587–597, 2015.
- [21] P. Mathuria and R. Bhakar, "GenCo's Integrated Trading Decision Making to Manage Multimarket Uncertainties," *Power Systems, IEEE Transactions on*, vol. PP, no. 99, pp. 1–10, 2014.
- [22] A. Soroudi and M. Ehsan, "IGDT Based Robust Decision Making Tool for DNOs in Load Procurement Under Severe Uncertainty," *Smart Grid, IEEE Transactions on*, vol. 4, no. 2, pp. 886–895, 2013.
- [23] P. Cuffe, P. Smith, and A. Keane, "Capability chart for distributed reactive power resources," *IEEE Transactions on Power Systems*, vol. 29, no. 1, pp. 15–22, 2014.
- [24] P. M. D. O. D. Jesus, "Renumeration of distributed generation: A holistic approach," Ph.D. dissertation, Univ. Porto, Porto, Portugal, 2007.
- [25] GAMS, "GAMSIDE," 2015. [Online]. Available: <http://www.gams.com/>

Conor Murphy received the B.Sc and M.E degrees in electrical engineering from University College Dublin, Dublin, Ireland, in 2011 and 2012, respectively. He is currently pursuing the Ph.D. degree in the School of Electrical and Electronic Engineering, University College Dublin, Dublin, Ireland. His research interests include the integration of distributed generation, reactive power control and AC optimal power flow.

Alireza Soroudi (M'14) received the B.Sc. and M.Sc. degrees from Sharif University of Technology, Tehran, Iran, in 2002 and 2004, respectively, both in electrical engineering, and the Ph.D. degree in electrical engineering from Grenoble Institute of Technology (Grenoble-INP), Grenoble, France, in 2011. He is currently a senior researcher with the School of Electrical and Electronic Engineering, University College Dublin, Dublin, Ireland, with research interests in uncertainty modeling and optimization techniques applied to smart grids, power system planning, and operation. He is a member of Iran's National Elites Foundation (INEF) and the winner of the ENRE Young Researcher Prize at the INFORMS 2013.

Andrew Keane received the B.E. and Ph.D. degrees in electrical engineering from University College Dublin, Ireland, in 2003 and 2007, respectively. He is currently a Senior Lecturer with the School of Electrical and Electronic Engineering, University College Dublin. He has previously worked with ESB Networks, the Irish Distribution System Operator. His research interests include power system planning and operation, distributed energy resources, and distribution networks.