



Title	Using the Root Locus Method to Analyze Pathological Oscillations in Neurological Diseases
Authors(s)	De Paor, Annraoi, Davidson, Claire M., Lowery, Madeleine M.
Publication date	2014-05-20
Publication information	De Paor, Annraoi, Claire M. Davidson, and Madeleine M. Lowery. "Using the Root Locus Method to Analyze Pathological Oscillations in Neurological Diseases." IEEE, May 20, 2014. https://doi.org/10.1109/ELEKTRO.2014.6848956 .
Conference details	2014 ELEKTRO: 10th International Conference, Slovak Republic, 19-20 May 2014
Publisher	IEEE
Item record/more information	http://hdl.handle.net/10197/10891
Publisher's statement	© 2014 IEEE. Personal use of this material is permitted. Permission from IEEE must be obtained for all other uses, in any current or future media, including reprinting/republishing this material for advertising or promotional purposes, creating new collective works, for resale or redistribution to servers or lists, or reuse of any copyrighted component of this work in other works.
Publisher's version (DOI)	10.1109/ELEKTRO.2014.6848956

Downloaded 2026-05-01 23:41:35

The UCD community has made this article openly available. Please share how this access benefits you. Your story matters! (@ucd_oa)



© Some rights reserved. For more information

Using the Root Locus Method to Analyze Pathological Oscillations in Neurological Diseases

Annraoi M. de Paor*, Clare M. Davidson*, and Madeleine M. Lowery*

*School of Electrical, Electronic and Communications Engineering, National University of Ireland, Dublin (UCD), Belfield, Dublin 4, Ireland, e-mail: madeleine.lowery@ucd.ie.

Abstract—In recent years the authors have developed what appears to be a very successful phenomenological model for analyzing the role of deep brain stimulation (DBS) in alleviating the symptoms of Parkinson's disease. In this paper, we extend the scope of the model by using it to predict the generation of new frequencies from networks tuned to a specific frequency, or indeed not self-oscillatory at all. We have discussed two principal cases: firstly where the constituent systems are coupled in an excitatory-excitatory fashion, which we designate by "+/+"; and secondly where the constituent systems are coupled in an excitatory-inhibitory fashion, which we designate "+/-". The model predicts that from a basic system tuned to tremor frequency we can generate an unlimited range of frequencies. We illustrate in particular, starting from systems which are initially nonoscillatory, that when the coupling coefficient exceeds a certain value, the system begins to oscillate at an amplitude which increases with the coupling strength. Another very interesting feature, which has been shown by colleagues of ours to arise through the coupling of complicated networks based on the physiology of the basal ganglia, can be illustrated by the root locus method which shows that increasing and decreasing frequencies of oscillation, existing simultaneously, have the property that their geometric mean remains substantially constant as the coupling strength is varied. We feel that with the present approach, we have provided another tool for understanding the existence and interaction of pathological oscillations which underlie, not only Parkinson's disease, but other conditions such as Tourette's syndrome, depression and epilepsy.

Index Terms—Deep brain stimulation, Parkinson's disease, control theory, oscillation suppression, computational model

I. INTRODUCTION

PARKINSON'S disease is a progressive and debilitating neuroLogical condition. It is characterized by a Loss of the neurotransmitter dopamine from the substantia nigra pars compacta region of the brain. Dopamine plays a role in the control of movement, and its depletion leads to a number of hallmark motor symptoms of the disease including bradykinesia, akinesia, rigidity and tremor. Correlation between these motor symptoms and abnormal pathological activity recorded from the cortico - basal

ganglia region of Parkinsonian patients in the form of local field potentials (LFPs) has been observed. This activity is typically recorded as an increase in spontaneous firing rate and periodic oscillatory activity [1], [2], [3]. Oscillations ranging from frequencies below 7Hz [4], [5], [6] up to about 300 Hz [7], [8] have been recorded. In particular, a correlative link has been established between bradykinesia and rigidity and pathological oscillatory activity in the beta band (15-30 Hz) [9], [10], as well as a relationship between limb tremor and oscillatory activity in the tremor range (3-10 Hz) [11]. It is hypothesized that this pathological activity arises from the loss of segregation within the different nuclei of the basal ganglia network [12], and that this may occur as a result of the loss of dopamine associated with Parkinson's disease [13]. Drug treatments which aim to either replenish the level of dopamine or mimic its action are successfully used to treat Parkinson's disease in the early stages. However as the disease progresses, drug therapy is often no longer enough to control the symptoms of the disease.

Deep brain stimulation (DBS) is an established and effective method of treating the symptoms of medically refractive Parkinson's disease [14], amongst other neurological and psychological disorders. Effective targets for the application of DBS in Parkinson's disease include the subthalamic nucleus (STN), the globus pallidus pars interna (GPi), the globus pallidus pars externa (GPe) and the pedunculopontine nucleus (PPN). DBS suppresses the pathological neural activity [10], [15], with an improvement in the motor symptoms also occurring, although a direct causal link has yet to be established.

In [16], [17], a computational model of Parkinsonian pathological oscillatory activity and its suppression with the application of high frequency stimulation is presented. The model is a macroscopic neural-mass type model and aims to capture the key features of a synchronized group of neurons in a mathematically tractable manner. The model has been shown to produce theoretical results that provide a fit in close agreement with clinical data published in [14], [18] and also provided by the University of Oxford.

In this study, the model presented in [16] is used as the basis with which to explore the oscillatory activity in self-oscillating and non-self-oscillating coupled Loops.

We suggest that the interaction between distinct loops either tuned to a particular frequency or inherently non-oscillatory can give rise to oscillations at other frequencies. We explore this hypothesis using two inter-coupled loops set to produce oscillations in the tremor range of frequencies, although this could easily be extended to encompass a wide range of frequencies such as appear in the Parkinsonian basal ganglia LFP recordings [7], [8], [19], [20]. Concepts from control theory, in particular the use of root locus analysis, are applied to analyze the model.

II. METHODS

In this paper we present results obtained in our studies so far of the generation of the multitude of frequencies observed in the basal ganglia from the inter-coupling of our basic model shown in Fig. 1. For $g_1 = g_2 > 0$ we have “+/-” coupling and for $g_1 = -g_2 < 0$ we have “+/-” coupling. For small signal analysis the arctan

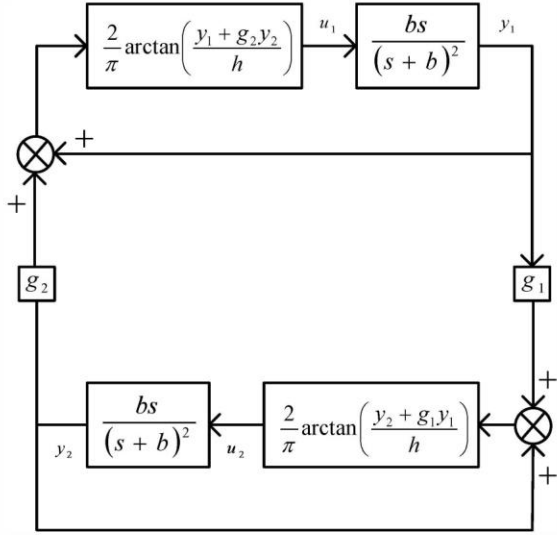

Figure 1. The basic system considered. +/- coupling has $g_1 = g_2 > 0$; +/- coupling has $g_1 = -g_2 < 0$.

nonlinearities are replaced by their small signal gains

$$\frac{d}{dz} \left\{ \frac{2}{\pi} \arctan \left(\frac{z}{h} \right) \right\} \Big|_{z \rightarrow 0} = \frac{2}{\pi h} \quad (1)$$

The small signal equivalent circuit is shown in Fig. 2, where we have introduced the closed loop transfer functions of the two feedback loops.

The characteristic polynomial of the small signal system is

$$P(s) = \left[(s+b)^2 - \frac{2b}{\pi h} s \right]^2 - \left[\frac{2b}{\pi h} \right]^2 g_1 g_2 \cdot s^2 \quad (2)$$

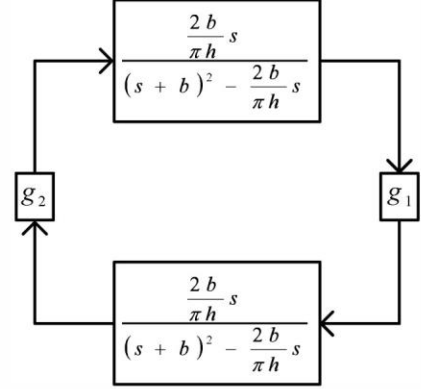

Figure 2. Small signal (linearized) equivalent of Fig. 1.

Our tool for the study of $P(s)$ is the root locus method [21], [22], based here on the observation that $P(s)$ is of the form

$$P(s) = N^2(s) - KM^2(s) \quad (3)$$

with

$$\begin{aligned} N(s) &= (s+b)^2 - \frac{2b}{\pi h} s \\ M(s) &= s \\ K &= \left[\frac{2b}{\pi h} \right]^2 g_1 g_2 \end{aligned} \quad (4)$$

Substituting

$$s = \sigma + j\omega \quad (5)$$

in (3) and denoting

$$\begin{aligned} N(s) &= A + jB \\ M(s) &= C + jD \end{aligned} \quad (6)$$

the roots of the characteristic equation i.e. the values of s for which $P(s) = 0$, are governed by

$$(A + jB)^2 - K(C + jD)^2 = 0. \quad (7)$$

Equating the real and imaginary parts of (7) separately to zero (noting that K is a **real** parameter) gives the root locus equation as

$$[AD - BC] \cdot [AC + BD] = 0 \quad (8)$$

conveniently given here factorized into two parts. The first part, as we shall show below, corresponds to $0 < K < \infty$ (+/+), and the second to $-\infty < K < 0$ (+/-). From (4) we have, subject to (5),

$$A = \sigma^2 - \omega^2 + 2b \left[1 - \frac{1}{\pi h} \right] \sigma + b^2$$

$$B = 2\sigma\omega + 2b\omega \left[1 - \frac{1}{\pi h} \right]$$

$$\begin{aligned} C &= \sigma \\ D &= \omega \end{aligned} \quad (9)$$

The root locus equation for the +/+ condition is $AD - BC = 0$, which is readily decomposed into two parts,

$$\omega = 0 \quad (10)$$

and

$$\sigma^2 + \omega^2 = b^2 \quad (11)$$

Equation (10) simply indicates that part of the root locus lies on the real axis. Evans' root locus sketching rules can be applied, and immediately tell us that this is the complete real axis, since there are two real poles or zeros on this axis. The root locus whose equation is

$$AD - BC = 0 \quad (12)$$

is shown in Fig.3, for $b = 10\pi$, $h = 0.3$ which gives double "poles" (roots of $N^2(s) = 0$) at

$$s = 1.9174 \pm j31.3574 \quad (13)$$

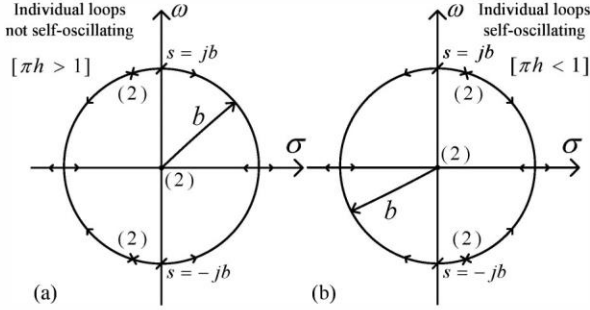

Figure 3. (a) shows root motion for non-oscillatory system ($\pi h > 1$). As the gain is increased, the system begins to oscillate when a pair of complex conjugate roots cross the imaginary axis. The frequency of oscillation decreases with increasing gain. (b) is for a self-oscillatory system ($\pi h < 1$). As the gain increases one frequency of oscillation increases slightly then disappears as the corresponding complex pair of roots enters the left half plane. The other complex pair move to the right, with frequency decreasing.

If we had $\pi h > 1$, the "poles" would be in the left half plane, but the circle would be followed to the left as well as to the right as K is increased, and the system would be just on the point of oscillation at $s = \pm jb$, and oscillatory beyond that. The "+/-" root locus is described by

$$AC + BD = 0. \quad (14)$$

This gives

$$\omega^2 = \sigma \left[\frac{b^2}{2b \left[\frac{1}{\pi h} - 1 \right] - \sigma} - \sigma \right]. \quad (15)$$

Two sketches of the corresponding root locus are shown in Fig. 4. It is noteworthy here that for $\frac{1}{\pi h} < 1$ (e.g. $h = 0.4$) the locus is confined entirely to the left half plane. This shows that oscillations **cannot** be induced by increasing g_1 or g_2 in the "+/-" situation: the individual loops must be in self-oscillation, as indicated by the right half plane branches in Fig. 4.

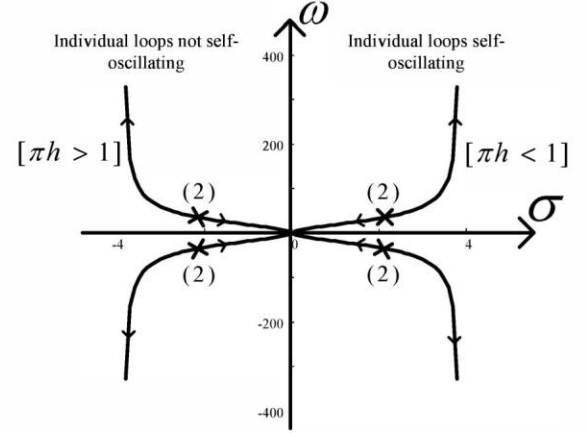

Figure 4. Root locus sketches for individual loops self-oscillating (right half plane) and not self-oscillating (left half plane).

III. RESULTS

Firstly we studied the onset of oscillations in the "+/+" situation with $\pi h > 1$, taking $h = 0.4$ (individual loops not self-oscillatory). The branches now start from the "poles" shown in the left half plane in Fig. 3, and follow the circle to the right as g is increased. A simple application of the root locus calibration equation

$$|K| = \frac{|N^2(s)|}{|M^2(s)|} \quad (16)$$

at either crossing point of the imaginary axis, $s = \pm jb$, gives the critical value of $g_1 = g_2$

$$g_{1,2} = [\pi h - 1]. \quad (17)$$

This is illustrated in Fig. 5.

The angular frequency of oscillation of y_1 as a function of g_1 , derived by simulating the system in Fig. 1, also with $h = 0.4$, is plotted in Fig. 6. The decrease in frequency with increase in coupling strength $g_1 g_2$ is notable. What we show here is that such a decrease in frequency could arise from "+/+" coupling of closely coupled neurons in the basal ganglia, or indeed other centers of the brain.

We now turn to "+/-" coupling, for which the root loci, in self-oscillatory and non-oscillatory modes, are shown in Fig. 4. The interesting feature here is that not

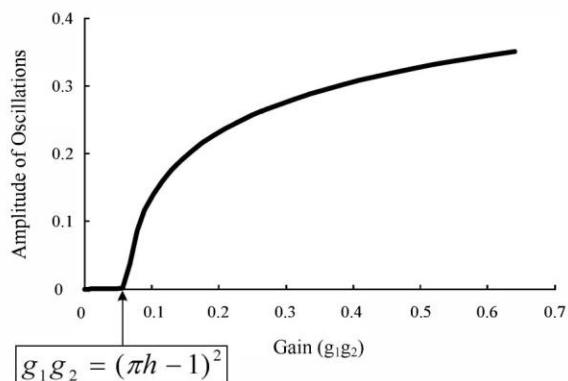

Figure 5. Amplitude of oscillation as a function of gain (g_1g_2) for a value of $h = 0.4$ (system is not self-oscillatory). The curve is derived by simulation of the system shown in Fig. 1.

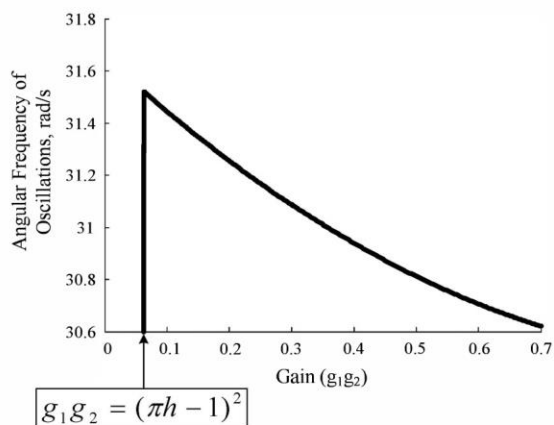

Figure 6. The angular frequency of oscillation of y_1 as a function of gain (g_1g_2) derived by simulating the system shown in Fig. 1 for the “+/-” case. The loops are not self-oscillatory, with $h = 0.4$.

only can frequencies less than that of tremor (our basic oscillator frequency) be generated, but also frequencies much higher. This agrees with the observations of Foffani et. al [7], [8], who have observed frequencies up to 300 Hz in the human STN.

Figure 7, corresponding to the right half plane root locus branches in Fig. 4, shows the increasing and decreasing frequencies which can be generated by varying $g_1 = -g_2$ in the “+/-” situation. We have also illustrated the geometric mean of these two frequencies, which is almost constant. This feature has been noted by colleagues in a more complex model based on the actual layout of the basal ganglia [23]. It is fascinating to see it emerge here also, in our much simpler phenomenological model of LFPs, observed in the neighborhood of oscillating neurons, without explicit reference to their anatomical arrangement.

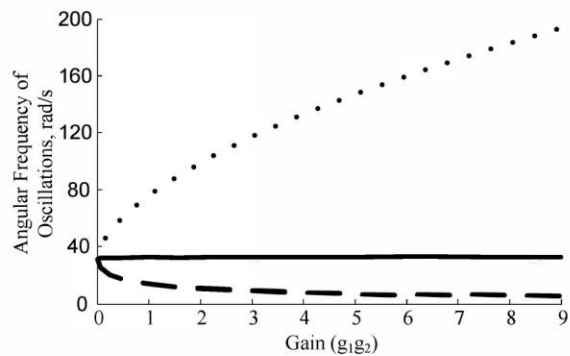

Figure 7. The angular frequencies of oscillation of y_1 as a function of gain (g_1g_2) derived by simulating the system shown in Fig. 1, for the “+/-” case, with $h = 0.3$ (system self-oscillatory). The geometric mean of the two frequencies, which remains almost constant, is also included.

IV. DISCUSSION

In this paper we have followed an observation made in [19] that “neurons exhibiting oscillatory activity at tremor frequency (typically 4-6 Hz) are located in the dorsal region of the STN, where neurons with beta activity (typically 15-30 Hz) are observed.” This suggested to us that a study of interactions of our basic oscillator which has proved of great value in matching DBS results from [14] and [18], might throw light on the variety of frequencies observed in the basal ganglia of Parkinsonian patients. We have found that “+/-” coupling can generate all frequencies below tremor. The higher frequency bands most often observed in Parkinson’s disease are beta (15-30 Hz) and gamma (35-80 Hz), but frequencies up to 300 Hz have been observed [7], [8]. The beta band oscillations are implicated in the seizure of gait, whereas the gamma band oscillations are considered pro-kinetic. However, we have shown that gamma and other higher frequencies, can be generated by “+/-” coupling of neurons tuned to much lower frequencies, illustrated here by a typical tremor frequency, 5 Hz ($=10\pi$ rad/s). It seems possible that “+/-” coupling of neurons tuned to tremor (or other) frequencies could generate the whole gamut of frequencies observed in disease states correlated with pathological oscillations in the basal ganglia and other centers.

ACKNOWLEDGMENTS

The authors are very grateful to Professor Alim-Louis Benabid, Joseph Fourier University of Grenoble, Professor Peter Brown, University of Oxford, and Professor Warren Grill, Duke University, for permission to use their experimental results in the studies which have led to those outlined here.

REFERENCES

- [1] M. D. Bevan, P. J. Magill, D. Terman, J. Bolam, and C. J. Wilson, "Move to the rhythm: oscillations in the subthalamic nucleus external globus pallidus network," *Trends in Neurosciences*, vol. 25, no. 10, pp. 525 - 531, 2002.
- [2] W. D. Hutchison, J. O. Dostrovsky, J. R. Walters, R. Courtemanche, T. Boraud, J. Goldberg, and P. Brown, "Neuronal oscillations in the basal ganglia and movement disorders: Evidence from whole animal and human recordings," *The Journal of Neuroscience*, vol. 24, no. 42, pp. 9240-9243, 2004.
- [3] A. Raz, E. Vaadia, and H. Bergman, "Firing patterns and correlations of spontaneous discharge of pallidal neurons in the normal and the tremulous l-methyl-4-phenyl-1,2,3,6-tetrahydropyridine vervet model of parkinsonism," *The Journal of Neuroscience*, vol. 20, no. 22, pp. 8559-8571, 2000.
- [4] P. Brown, "Oscillatory nature of human basal ganglia activity: Relationship to the pathophysiology of parkinson's disease," *Movement Disorders*, vol. 18, no. 4, pp. 357-363, 2003.
- [5] F. Alonso-Frech, I. Zamarbide, M. Alegre, M. C. Rodriguez-Oroz, J. Guridi, M. Manrique, M. Valencia, J. Artieda, and J. A. Obeso, "Slow oscillatory activity and levodopa-induced dyskinesias in parkinson's disease," *Brain*, vol. 129, no. 7, pp. 1748-1757, 2006. [6] M. Cassidy, P. Mazzone, A. Oliviero, A. Insola, P. Tonali, Y. D. Lazzaro, and P. Brown, "Movement-related changes in synchronization in the human basal ganglia," *Brain*, vol. 125, no. 6, pp. 1235-1246, 2002.
- [7] G. Foffani, A. Priori, M. Egidio, P. Rampini, F. Tamma, E. Caputo, K. Moxon, S. Cerutti, and S. Barbieri, "300-hz subthalamic oscillations in parkinson's disease," *Brain*, vol. 126, no. 10, pp. 2153-2163, 2003.
- [8] G. Foffani, G. Ardolino, P. Rampini, F. Tamma, E. Caputo, M. Egidio, S. Cerutti, S. Barbieri, and A. Priori, "Physiological recordings from electrodes implanted in the basal ganglia for deep brain stimulation in parkinson's disease. the relevance of fast subthalamic rhythms," in *Re-Engineering of the Damaged Brain and Spinal Cord*. Springer, 2005, pp. 97-99.
- [9] N. Ray, N. Jenkinson, S. Wang, P. Holland, J. Brittain, C. Joint, J. Stein, and T. Aziz, "Local field potential beta activity in the subthalamic nucleus of patients with parkinson's disease is associated with improvements in bradykinesia after dopamine and deep brain stimulation," *Experimental Neurology*, vol. 213, no. 1, pp. 108-113, 2008.
- [10] A. A. Kuhn, F. Kempf, C. Brucke, L. Gaynor Doyle, I. MartinezTorres, A. Pogosyan, T. Trottenberg, A. Kupsch, G.-H. Schneider, M. I. Hariz, W. Vandenberghe, B. Nuttin, and P. Brown, "High-frequency stimulation of the subthalamic nucleus suppresses oscillatory beta activity in patients with parkinson's disease in parallel with improvement in motor performance," *The Journal of Neuroscience*, vol. 28, no. 24, pp. 6165-6173, 2008.
- [11] P. Tass, D. Smimov, A. Karavaev, U. Barnikol, T. Barnikol, I. Adamchic, C. Hauptmann, N. Pawelczyk, M. Maarouf, Y. Sturm, H.-J. Freund, and B. Bezrucho, "The causal relationship between subcortical local field potential oscillations and parkinsonian resting tremor," *Journal of Neural Engineering*, vol. 7, no. 1, p. 016009, 2010.
- [12] H. Bergman, A. Feingold, A. Nini, A. Raz, H. Siovin, M. Abeles, and E. Vaadia, "Physiological aspects of information processing in the basal ganglia of normal and parkinsonian primates," *Trends in Neurosciences*, vol. 21, no. 1, pp. 32 - 38, 1998.
- [13] M. Rivlin-Etzion, O. Marmor, G. Heimer, A. Raz, A. Nini, and H. Bergman, "Basal ganglia oscillations and pathophysiology of movement disorders," *Current Opinion in Neurobiology*, vol. 16, no. 6, pp. 629 - 637, 2006.
- [14] A. Benabid, P. Pollak, D. Hoffmann, C. Gervason, M. Hommel, J. Perret, J. de Rougemont, and D. Gao, "Long-term suppression of tremor by chronic stimulation of the ventral intermediate thalamic nucleus," *The Lancet*, vol. 337, no. 8738, pp. 403 - 406, 1991, originally published as Volume I, Issue 8738.
- [15] P. Silberstein, A. Pogosyan, A. A. Kuhn, G. Hotton, S. Tisch, A. Kupsch, P. Dowsey-Limousin, M. I. Hariz, and P. Brown, "Cortic o-cortical coupling in parkinson's disease and its modulation by therapy," *Brain*, vol. 128, no. 6, pp. 1277-1291, June 2005.
- [16] c. M. Davidson, A. M. de Paor, and M. M. Lowery, "Application of describing function analysis to a model of deep brain stimulation," *IEEE Transactions on Biomedical Engineering*, vol. 61, pp. 957965, 2014.
- [17] --, "Insights from control theory into deep brain stimulation for relief from parkinson's disease," in *ELEKTRO*, 2012. IEEE, 2012, pp. 2-7.
- [18] S. E. Cooper, A. M. Kuncel, B. R. Wolgamuth, A. Rezaei, and W. M. Grill, "A model predicting optimal parameters for deep brain stimulation in essential tremor," *Journal of clinical neurophysiology*: official publication of the American Electroencephalographic Society, vol. 25, no. 5, p. 265, 2008.
- [19] M. Weinberger, W. D. Hutchison, A. M. Lozano, M. Hodaie, and J. O. Dostrovsky, "Increased gamma oscillatory activity in the subthalamic nucleus during tremor in parkinson's disease patients," *Journal of neurophysiology*, vol. 101, no. 2, pp. 789-802, 2009.
- [20] S. Marceglia, A. M. Bianchi, G. Baselli, G. Foffani, F. Cogiamanian, N. Modugno, S. Mrkic-Spota, A. Priori, and S. Cerutti, "Interaction between rhythms in the human basal ganglia: application of bispectral analysis to local field potentials," *Neural Systems and Rehabilitation Engineering, IEEE Transactions on*, vol. 15, no. 4, pp. 483-492, 2007.
- [21] H. M. Power and R. J. Simpson, *Introduction to dynamics and control*. McGraw-Hill (London and New York), 1978.
- [22] C. Phillips and R. Harbor, *Feedback control systems*, 4th ed. Prentice Hall, 2000.
- [23] G. Kang and M. Lowery, "Interaction of oscillations, and their suppression via deep brain stimulation, in a model of the corti co-basal ganglia network," *Neural Systems and Rehabilitation Engineering, IEEE Transactions on*, vol. 21, no. 2, pp. 244-253, 2013.