



Title	A simulation model for the management and expansion of extended port terminal operations
Authors(s)	Cimpeanu, Radu, Devine, Mel T., O'Brien, Conor
Publication date	2017-02
Publication information	Cimpeanu, Radu, Mel T. Devine, and Conor O'Brien. "A Simulation Model for the Management and Expansion of Extended Port Terminal Operations." Elsevier BV, February 2017. https://doi.org/10.1016/j.tre.2016.12.005 .
Publisher	Elsevier BV
Item record/more information	http://hdl.handle.net/10197/10975
Publisher's statement	This is the author's version of a work that was accepted for publication in Transportation Research Part E: Logistics and Transportation Review. Changes resulting from the publishing process, such as peer review, editing, corrections, structural formatting, and other quality control mechanisms may not be reflected in this document. Changes may have been made to this work since it was submitted for publication. A definitive version was subsequently published in Transportation Research Part E: Logistics and Transportation Review (98, (2017)) https://doi.org/10.1016/j.tre.2016.12.005
Publisher's version (DOI)	10.1016/j.tre.2016.12.005

Downloaded 2026-05-01 23:37:43

The UCD community has made this article openly available. Please share how this access benefits you. Your story matters! (@ucd_oa)



© Some rights reserved. For more information

A simulation model for the management and expansion of extended port terminal operations

Radu Cimpanu^{a,*}, Mel T. Devine^{b,c}, Conor O'Brien^{d,e}

^a*Department of Mathematics, Imperial College London, SW7 2AZ, London, United Kingdom*

^b*Mathematics Applications Consortium for Science and Industry (MACSI), Department of Mathematics and Statistics, University of Limerick, Limerick, Ireland*

^c*Economic and Social Research Institute, Department of Economics, Trinity College Dublin, Dublin, Ireland*

^d*RUSAL Aughinish Alumina, Limerick, Ireland*

^e*Cobe Projects Ltd., Churchfield, Clarina, Limerick, Ireland*

Abstract

This study introduces a discrete event simulation model for the analysis of bulk carrier unloading and material transport, storage and discharge at Europe's largest alumina refinery, RUSAL Aughinish Alumina. With novel features such as the integration of additional unloading functionality, auxiliary infrastructure units, as well as efficient maintenance scheduling into the material processing chain, the model is used to predict and evaluate the performance gain in the port system in the context of long-term investment and planning scenarios. Promising strategic directions in terms of large scale performance indicators such as berth occupancy and costs have been identified.

Keywords: marine terminal operation, infrastructure expansion, strategic management, computing under uncertainty, discrete event simulation model

1. Introduction

The Bayer process is the method by which alumina (aluminium oxide) is refined from bauxite. On Aughinish Island, located on the Shannon estuary in the south-west of Ireland, RUSAL use the Bayer process to refine bauxite into alumina. To do this, they import bauxite from countries like Brazil and Guinea, which, once refined to alumina, is then exported to different regions around the world. RUSAL operates and maintains a port terminal as part of their overall plant in order to meet these shipping needs. The port terminal consists of an outer berth and an inner berth. The outer berth is typically used for the importation of bauxite, while the inner berth is used for the exportation of alumina in addition to the importation of other raw materials necessary for the operation of the port. For details on how these ships arrive and leave RUSAL's port terminal we refer the reader to previous work on this system (Cimpanu et al. (2015)).

Once a bauxite ship arrives at the port outer berth, the unloading process begins. From the bulk carrier, the bauxite is unloaded onto conveyor belts and is subsequently transported to storage facilities. The detailed steps in

*Corresponding author

Email addresses: radu.cimpanu11@imperial.ac.uk (Radu Cimpanu), mel.devine@esri.ie (Mel T. Devine), conorobrien@hotmail.com (Conor O'Brien)

URL: <http://www3.imperial.ac.uk/people/radu.cimpanu11> (Radu Cimpanu)

this procedure are highlighted in subsection 2.1. The material is then utilised and treated further in the production line with the final aim of it being refined into alumina.

We construct a discrete event simulation model that reproduces and expands the functionality of the port terminal and its auxiliary facilities. This methodology is used due to the formation of queues before ships dock at the port, as well as the event-based nature of the port activities. Following a successful validation, a sensitivity analysis is conducted and the effects and benefits of investing in upgrading crucial port infrastructure such as unloading machines, conveyor belts and storage facilities are accurately assessed.

In previous investigations of this setup (Cimpeanu et al. (2015)), a model of the port's inner berth has been presented. The model successfully captured the queueing of ships before their arrival at RUSAL's port and the unloading/loading of their cargo. Tidal constraints, stochastic arrival times and random events that delayed ship processing (such as extreme weather) have been taken into account in the respective formulation. The model was used to analyse the impact of variations in the port activity on several performance indicators such as berth occupancy and costs. In the present work, we develop a model of the outer berth which significantly, and, in contrast to previous work, also models the following non-standard features:

1. extension of the unloading infrastructure from a single- to a two-server system;
2. specialised maintenance scheduling;
3. the conveyor system of the plant;
4. storage facilities and discharge functionality.

The specific outer berth operations (originating from the much larger ships and the detailed manner in which the bauxite stored in the compartments therein is handled) also differ greatly from the inner berth modelling.

We perform a detailed sensitivity analysis focusing on the new elements of the system and identify the key aspects of material handling within the complex port network using recent real life data. The study addresses port logistics management and expansion considering interactions between the functional units highlighted above (berth operations, material unloading, transport, storage and discharge mechanisms) within an integrated large scale environment.

The paper is organised as follows: firstly, in Section 1.1, the literature on modelling shipping processes is reviewed. In Section 2, the discrete event simulation model is detailed. Section 3 is dedicated to the validation of the system and to the examination of designed test cases, presentation of results and their analysis. Finally, discussions and conclusions are presented in Sections 4 and 5, respectively.

1.1. Previous studies

Discrete event simulation models have been used successfully throughout the last several decades to tackle the dynamic behaviour of multi-component port systems. Angeloudis and Bell (2011) and later Carlo et al. (2014) present overviews of some of the most recent literature on the topic and outline the current industry trends and developments, with particular inclination towards container type ship explorations, as well as ship to yard transport operations (Legato et al. (2013); Petering (2009)). The essential aspect of these review studies is that berth terminal operation modelling is a rich and vibrant area, with immense scope for analytical and numerical investigations. In

Dragović et al. (2016) a detailed classification of such applications is presented and the authors argue that simulation modelling offers the most realistic results when searching for solutions in the maritime and transport industries. A wide range of studies are discussed therein and in what follows we expand on some of the most relevant research related to the present investigation.

For instance, following a detailed statistical analysis, Carteni and De Luca (2010) use simulation modelling to analyse terminal operations at the Port of Salerno in Italy, where handling activities are modelled using well-defined stochastic variables. By contrast, uncertainty in the present work is modelled using sampling from empirical distributions. Longo et al. (2013) also use discrete event simulation modelling to replicate the activity of the same port in Italy. As we will also show later, they find that inter-arrival times and unloading/loading rates, amongst others, are crucial factors in seaport management. The large number of variables present in the system necessitates a stringent validation procedure, typical of informative simulation models in this area. Qu and Meng (2012) develop a similar model and apply it to ships movements in the Singapore Straits. Using experienced personnel they embed expert judgement into the model's decision-making process.

In typical real life scenarios, we find factors of uncertainty which are very important in the overall dynamics of the system (Legato et al., 2014). The integration of non-deterministic features plays a fundamental role in our proposed model as well. In practice operators and shipping lines often agree on arrival windows rather than arrival times, with far-reaching implications for the management of the port activity, as highlighted by Hendriks et al. (2010). Using the Antwerp terminal as an example, the peak loading and number of quay cranes are minimised. On a larger scale, Wang et al. (2015) emphasise the connection between the activity of port terminals and the shipping lines transporting containers from their origin to their destination ports. Port operators work based on requirements and information from the shipping lines, thus a collaborative mechanism is proposed to lower bunker and inventory costs, as well as ensure a robust assessment and transfer of knowledge between the two parts. Ship arrival scheduling with stochastic modelling has also been identified by Zhen et al. (2011) and Zhen and Chang (2012) as having a significant impact in improving the efficiency of port terminal operations (see also Du et al. (2011)).

A multitude of studies use numerical techniques to tackle distinct but related performance issues within typical port environments. For example, Bugaric and Petrovic (2007) and Bugaric et al. (2012) use simulation modelling to show how capacity of port terminals can be increased without new capital costs, while similar lines of investigation have been explored in Bugaric et al. (2011) when a queuing theory model was utilised instead. Simulation modelling is also used in Douma et al. (2012) for a barge handling problem in the port of Rotterdam. In contrast to the present investigation, their work considers a competitive multi-player game between several barge operators. Tang et al. (2016) employ a simulation model to examine the effects of entrance dimensions on berth occupancy of a container terminal. An interesting alternative methodology via the use of Markov decision processes to model ship loading and unloading is used by Rida (2014) with the ultimate aim of reducing the total waiting time of auxiliary equipment in the port. Working towards a similar goal, the simulation-based approach of Longo (2010) is used to quantify the performance of the proposed framework to design improved inspection practices. Our study also assesses the impact of the duration of inspection periods, however, in contrast to Longo (2010), we measure its impact both individually and also in conjunction with upgrades to the infrastructure. Inter-connected component analysis is

also undertaken by Chang et al. (2010) and later by Song et al. (2012), who tackle berth allocation and quay crane scheduling simultaneously (rather than as separate elements). The authors of the latter investigation first discuss simple models and ultimately present a large scale model based on the PSA Singapore terminal.

Alongside the detailed analysis of port activity, one of the main aims of the present work is to inform an investment decision. Bielli et al. (2006) underline the fact that improving berth activity is often a compromise between developing the productivity of a present system against the costs and associated logistical complications of adding new equipment upgrades. Other studies that use simulation modelling of a port system to inform investment decisions include Demirci (2003), Lin et al. (2014) and Sun et al. (2013) who model the Trabzon Port in Turkey, the Humen Port in China, and the Brani terminal in Singapore, respectively. Similarly, Cortes et al. (2007) model the port of Seville to inform how current resources are able to manage present and future challenges facing the system in question. Other instances in the literature where simulation modelling is used for real world case studies of port systems include Legato and Mazza (2001) (Gioia Tauro, Italy), Bielli et al. (2006) (Casablanca), Shabayek and Yeung (2002) (Kwai Chung container terminals, Hong Kong), Yun and Choi (1999) (Pusan, Korea), Mat Tahar and Hussain (2000) (Port Kelang, Malaysia), and Verdonck et al. (2014) (Haven Genk, Belgium). The wealth of exploration possibilities has also encouraged the development of general simulation platforms, such as MicroPort, introduced by Sun et al. (2012). However, as is the case in the present context, often the very specific nature of the local port operations does not allow the usage of such a high level software approach, in which case mathematical or simulation modelling are the ideal tools to tackle the specialised features of a particular system.

The above mentioned studies are similar to the present work in that they model the movement of ships within a port network and consider variables such as inter-arrival times of ships and unloading/loading functionality. In addition, many of the previous investigations are also validated against real world data. However, the present study, as detailed above, considers novel features such as strategies for maintenance scheduling whilst also incorporating how onshore transportation and storage affect unloading rates and berth occupancy. Furthermore, a strength of our examination lies in the execution of the simulation study under statistical analysis for both input and output data during the validation study and the comprehensive scenario analysis.

Other contributions to the specialised literature use simulation for modelling of onshore material transport within a port system, such as Caballini et al. (2014), Fanti et al. (2015), Petering (2011), Saurí et al. (2014) and Tierney et al. (2014). Understanding the transfer of shipments is closely related to improvements in storage practice, which is the subject considered by Borgman et al. (2010), Guldogan (2010), van Asperen et al. (2013) and van Vianen et al. (2014). In contrast to the present study, the respective methodology is based on container movement via vehicles such as trucks rather than continuous material flow on conveyor systems directly towards dedicated storage facilities for specific raw materials. An exception to this is Iannone et al. (2016) who use discrete event simulation to model operations at a car terminal. Furthermore, these previous lines of study do not incorporate the movement of ships into and out of a port terminal, focusing exclusively on the target element of the logistic chain.

The present investigation builds on previous port terminal explorations and expands the former simulation framework (Cimpeanu et al. (2015)) to include several generalisations that severely affect the unique dynamics of the RUSAL Aughinish outer berth operations. A novel feature of this work is the non-trivial extension to the infrastructure and the associated maintenance policy. We integrate the entire material transport pipeline from

the arrival of bulk carriers to the handling of the specific unloading procedure, the delivery of the material onto conveyor belts and finally to the storage facilities. Many of these elements require non-standard modelling, which we believe provides the readers with a useful insight into several problems of interest in berth management.

2. Simulation model

We introduce a discrete simulation model capable of capturing the realistic material dynamics in the complex system. The proposed formulation combines the accurate modelling of the various functioning units within the extended port terminal with the integration of elements of uncertainty. This latter aspect is particularly beneficial in estimating and understanding the broader impact of new elements and/or upgrades, such as the inclusion of additional unloading units or the improvement of transport and storage facilities. This type of sensitivity analysis is not commonly considered in models that concentrate on individual features of the processing chain and is therefore one of the strengths of our model.

2.1. Ship processing

During each operational year, bulk carriers are due to arrive at the port terminal according to a shipping schedule. This schedule is naturally subject to change, with material requirements, costs and shipping company conditions often contributing to modifications in the schedule. In addition, it is not uncommon for weather- or ship-related delays to have a significant impact on the arrival time at the outer berth.

Two different varieties of bauxite (different in terms of composition and chemical properties) are brought into the refinery. The bulk carriers transporting this material are in the same family (seven-hatch Panamax ships), however have slight variations in terms of size (see Fig. 6). Furthermore, due to the differences in processing this material further in the plant, from this point onward we shall differentiate between ships unloading these materials as Type A and Type B bulk carriers.

With the aid of the schematic in Fig. 1, we briefly discuss the movement of each ship during the stages of interest in the context of the present study. Further relevant details of the geographical layout and the ship processing can also be found in Cimpeanu et al. (2015), where an overview of the procedures related to dynamics at the inner berth is presented. Here we focus primarily on the particularities of the outer berth dynamics, along with the newly introduced transport and storage elements, and refer the interested reader to previous work on this system.

The bulk carriers first reach Scatterry Island, situated 40 km west of Aughinish in the Shannon Estuary. This is a queueing point in which ships await a pilot to direct the vessel to the outer berth itself. Once the pilot is on board the ship, the time period allocated to the company for the processing of the ship begins. This interval is called *lay time* and is related to the size of each individual bulk carrier. Exceeding this period incurs demurrage costs, which are directly proportional to the number of additional hours required to process the respective ship. In ideal circumstances, the bulk carrier would at this point proceed to the outer berth for the next stages. There are several factors that may however affect the advancement of the ship. Firstly, the tidal window must be correct for the bulk carrier to berth. In particular, downstream tides are to be avoided, thus reducing the ship berthing times (and later on leaving times) to one hour after low tide and one hour before high tide. This is a demanding requirement, since it only allows ships to transition between Scatterry Island and the berth for a relatively small time window each day,

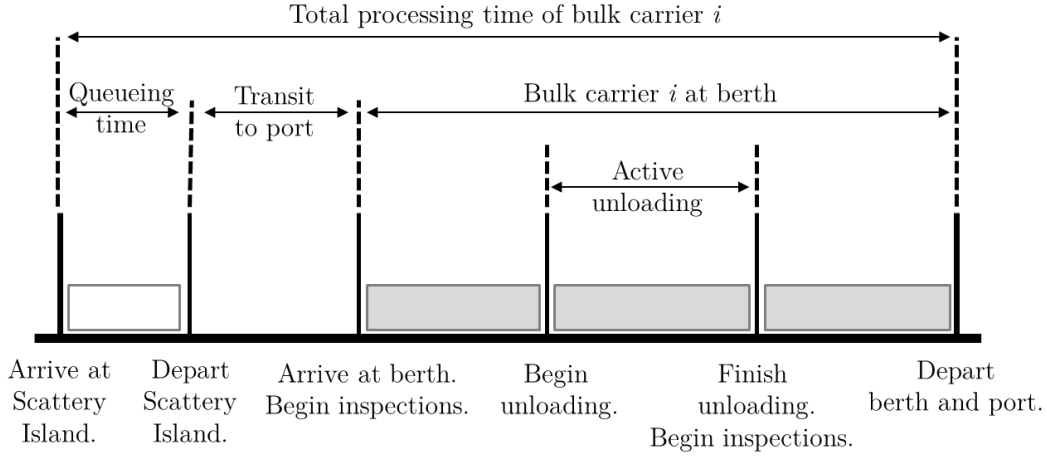

Figure 1: Schematic of individual bulk carrier processing steps.

however the regular nature of this geographical process makes it simpler to account for. Secondly, the berth must be free (only one ship can be processed at any given time), thus any delays in the processing of a previous ship will have an effect on present (and potentially future) bulk carriers to be processed.

Furthermore, a queue of ships may already be present at Scattery Island. Particularly after severe weather events, it is relatively common for several ships to be present in the queue. Even in the absence of such a scenario, there are instances when ships arrive very closely in time to one another, requiring the implementation of a sensible queue negotiation policy in order to decide which ship should be the first to depart towards the port terminal. We highlight that the non-standard feature of having a moderate distance between the queue and the processing point (the berth) also ensures that port congestion is avoided altogether. The traffic in the near vicinity of the port terminal is restricted due to the presented geographical constraints and the pressure of significant arrival of ships (or delays) is conveniently shifted towards Scattery Island, which has ample queueing capacity.

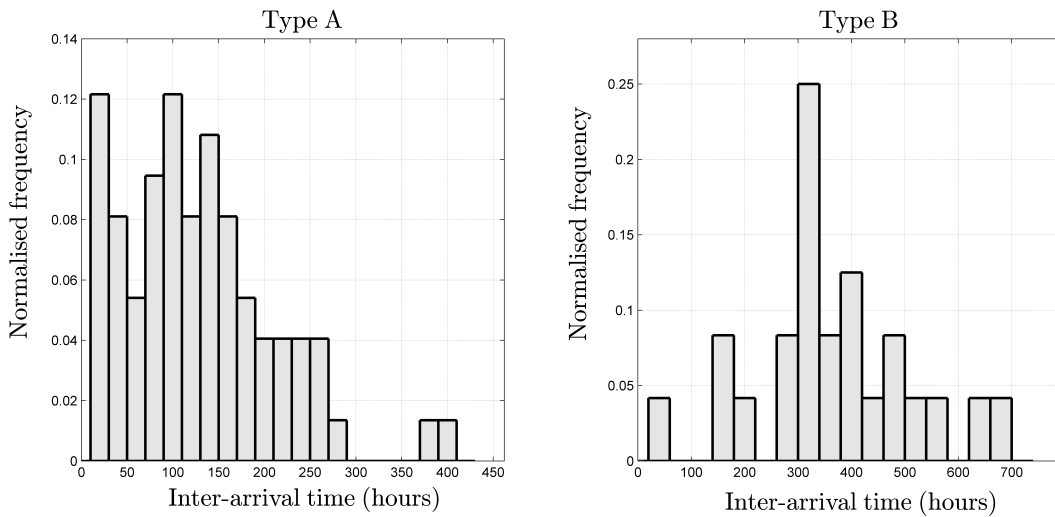

Figure 2: Discrete inter-arrival time distributions for Type A bulk carriers (left) and Type B bulk carriers (right).

As the ship arrival times are the primary cause of uncertainty in the model, we underline that a reliable Monte

Carlo sampling procedure is central to obtaining accurate results. Fig. 2 illustrates the frequency of ship arrivals and introduces the notion of inter-arrival times between ships. When modelling each activity year, we initially impose a certain number of ships of each type as input. Historical data provided by the company in the form of empirical (discrete) distributions is then used for populating the parameter space in terms of the number of hours between the arrival of any two given ships. The two schedules (for each ship time) are then merged and a master schedule is created, mirroring the effect of the yearly schedule received by the company in real life. Inverse cumulative probability distribution functions are generated from the provided empirical distributions, which are then sampled the appropriate number of times dictated by the number of ships modelled in the system. Start and end of the year effects are accounted for as well in order to limit the influence of outliers. From Fig. 2, we find that the distributions themselves reveal a relatively strong spread in both datasets, indicating variability in the system.

The journey time from Scatterry Island to the port terminal itself is of approximately three hours, including the berthing operations themselves. Each ship then undergoes a pre-unloading inspection conducted by an independent surveyor. If such an inspection reveals any mechanical failures that would hinder the unloading process or cause any safety concerns, repair work will be initiated at a nearby port in Foynes. In such a case, the shipping company would be responsible for both the time required to service a damaged bulk carrier, as well as the associated costs of the operations.

When the inspection is passed, the unloading procedure begins and the bauxite is transported from inside the bulk carriers onto a conveyor system, with details provided in the following subsection. Unloading may be affected by delays which are either weather-related (for instance, heavy rain that may damage the material quality or strong winds that may hinder the movement of the unloading equipment) or shore-related (for instance, equipment breakdown). Once the ship is unloaded, a post-unload inspection is carried out and, if within the appropriate tidal window, the ship departs the port terminal and the processing time for the respective bulk carrier is stopped. The next ship can then be brought in and the procedure is repeated for every scheduled bulk carrier.

Referring back to the step-by-step summary in Fig. 1, the presence of white or grey rectangles indicates the time intervals when a certain activity of the ship is to be conducted during the lay time allowance of the company itself. The transit to port is excluded from the total cost. During the stay at Scatterry Island, only the queueing time with a pilot on board is regarded as being under the responsibility of the company. The time required by the company to process the bulk carrier is then compared to the allocated lay time for the respective ship. In case this lay time is exceeded, demurrage costs are generated at a certain fixed rate for each bulk carrier type.

2.2. Unloading procedure

The bulk carriers considered in the present study are seven-hatch Panamax ships, a schematic of which is provided in Fig. 3. From a functional perspective, each ship contains seven separate storage units (hatches), in which the bauxite to be unloaded is transported up to the port terminal. Inside each hatch we distinguish a three-tier structure, the details of which are presented in the following paragraphs.

Phase I unloading (or cream digging) is characterised by high unloading rates due to the availability of material at the ship surface and ease of access for the unloaders. In phase II the unloading slows down, as less material can be extracted in each unloader movement (which incidentally also takes longer time). There are small variations

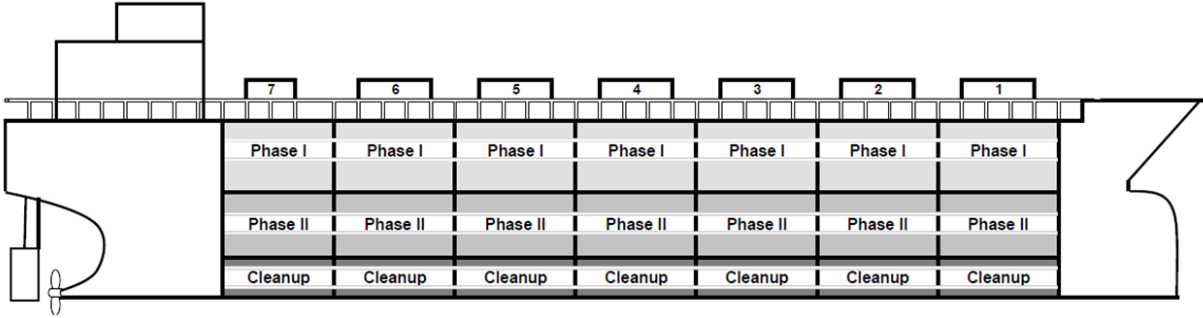

Figure 3: Seven-hatch ship structure and interior storage details, illustrating three distinct compartments within each hatch.

depending on the ship type, however normally the phase II digging rate amounts to approximately 55% of the phase I digging rate. Finally, during the last stage called the cleanup stage, material is only found at the bottom of each hatch and additional effort is required to rearrange this material in a manner which is convenient for the unloader to process. Thus the cleanup phase has a much lower digging rate, typically of less than 25% of the phase I rate. The material quantities and digging rates have been provided by RUSAL.

It is useful at this stage to characterise the time required to unload a hatch mathematically. We define t_U as the total unloading time for a typical ship in the queue. We also introduce h_{p1} as the number of hatches to be unloaded under a phase I digging rate, h_{p2} as the equivalent value for phase II digging and finally h_c as the number of hatches to be unloaded at cleanup rate. Each hatch will carry a certain amount of material, denoted as m_{xy} , where $x \in \{1, 2, c\}$ specifies the digging phase and y refers to the hatch number. Furthermore, each hatch is characterised by a certain unloading rate r_{xy} (with analogous meanings for x and y). Combining the above into a general formula for the total unloading time t_U , we obtain

$$t_U = \sum_{i=1}^{h_{p1}} \frac{m_{1i}}{r_{1i}} + \sum_{j=1}^{h_{p2}} \frac{m_{2j}}{r_{2j}} + \sum_{k=1}^{h_c} \frac{m_{ck}}{r_{ck}}. \quad (1)$$

For the seven-hatch Panamax ships considered in this study, the following simplifying assumptions can be made to customise equation (1) to the local system, namely:

1. each hatch has the same internal structure, thus $h_{p1} = h_{p2} = h_c = 7$;
2. each internal compartment in a certain phase has the same amount of material, i.e. $m_{1i} \equiv m_1 \forall i \in \{1, \dots, 7\}$, $m_{2i} \equiv m_2 \forall i \in \{1, \dots, 7\}$ and $m_{ci} \equiv m_c \forall i \in \{1, \dots, 7\}$;
3. similarly, the digging rate in a certain phase coincides for all hatches, i.e. $r_{1i} \equiv r_1 \forall i \in \{1, \dots, 7\}$, $r_{2i} \equiv r_2 \forall i \in \{1, \dots, 7\}$ and $r_{ci} \equiv r_c \forall i \in \{1, \dots, 7\}$;

An important aspect of the unloading process is the emptying of hatches in a specific sequence, dictated by safety and equipment restrictions. In particular, we note that the distribution of the weight of the material within the entire bulk carrier needs to be balanced (deballasting procedure) in order to avoid undesired displacement of the ship while at berth. The specific ordering of the hatches to be unloaded often requires the unloaders to move from the more externally positioned hatches, alternatively, until the middle hatch is reached in each phase.

The computed time t_U is at this stage unaffected by any form of delays and simply describes the unloading power of the equipment under no additional pressure.

While not directly entering the computation of the unloading time, it is important to note the contribution of the maintenance operations in the process as a whole. During intervals in which the machinery (the unloader itself or any other elements further in the pipeline) is under maintenance, the unloading procedure cannot start and the ship remains at berth awaiting to be serviced. There are two types of maintenance to be considered at the port terminal:

- *long-term* maintenance, which entails a large scale shutdown of the entire plant for facility inspections, restoration work and upgrades. Two such events are scheduled every operational year and span several days;
- *short-term* downtimes, often caused by unexpected equipment repair work, which produce delays in the order of hours to days.

The specific real life long-term maintenance imposition is inherited by the model, whereas short-term operations are accounted for as follows. From the historical data provided, a total amount of short-term maintenance hours and number of yearly downtimes related to them is extracted. This enables us to compute an average short-term maintenance period, which is then embedded into the model at regular time intervals throughout the operational year.

We proceed with a description of the transport and storage systems for the material unloaded at the port terminal.

2.3. Material transport and storage

The material unloaded from the ships is placed onto a conveyor system, which is a network of moving belts that stretch from the port terminal onto the jetty through a covered passage spanning several hundred meters and finally into the storage sheds, where the bauxite is held before entering the refining process further in the plant.

The precise geometrical features and layout of the conveyor system are beyond the scope of the present study, as they are not subject to change within a short timescale. Such detailed characteristics of the transportation mechanism are amassed under a single quantity, the amount of tons per hour that can be transported through the system from the ship to the sheds. In particular, an important quantity emerges in the form of a maximum amount of tons per hour that can be supported by the conveyor system. This limitation is in place due to mechanical features of the system, ranging from the power of the motors (affecting the speed of the belt) to the width of the belts themselves. The unloading rate cannot exceed the maximum capacity of the conveyor (expressed in the same units of tons per hour), as this would determine spillages and loss of material through the pipeline. To account for this in the model, we impose a limit of the unloading rate to within the operational capacity of the conveyor system. Upgrades of the various parts of the conveyor system would increase capacity and translate to an increase in the amount of maximum tons per hour that can be transported.

Two large storage sheds are found at the end of the bauxite transportation system, each hosting one of the different types of material (Type A and Type B). The sheds are each characterised by a certain capacity (in tons) and a discharge rate (in tons per hour) at which the material is removed from the sheds and taken through the next stages of refinement in the plant. The material demand is known a priori and the relative proportions required affect the shipping schedule at the beginning of the operational year. The sheds and the material dynamics within

represent the final point which is accounted for in the present model. If material reserves become too high and the storage capacity will be exceeded by further unloading, the unloading procedure has to be halted. If, on the other hand, material reserves become too low, additional equipment is required to gather the less accessible loads of bauxite, reducing the discharge rate until finally no more material is present. The load of the next ship would then replenish the reserves inside the appropriate shed.

Several upgrades are possible at the level of the sheds, two of which will be considered in future studies. We consider potential extensions to the capacity of the sheds, alleviating existing pressure in case of periods of heavy activity and continuous unloading. Such upgrades could also be accompanied by increases in the discharge rate in order to speed up the production process at the subsequent stages in the refinement.

2.4. Additional unloader

One of the main features of this study is the introduction and analysis of an additional unloading unit at the port terminal. The high amount of material currently processed at the plant and increasing levels of berth occupancy indicate that a significant upgrade would be necessary in order to meet increased material demands in the future. The existing unloading mechanism may be upgraded, however only minor improvements are anticipated. Therefore analysing the impact of an additional unloading unit is one of the most attractive options at present.

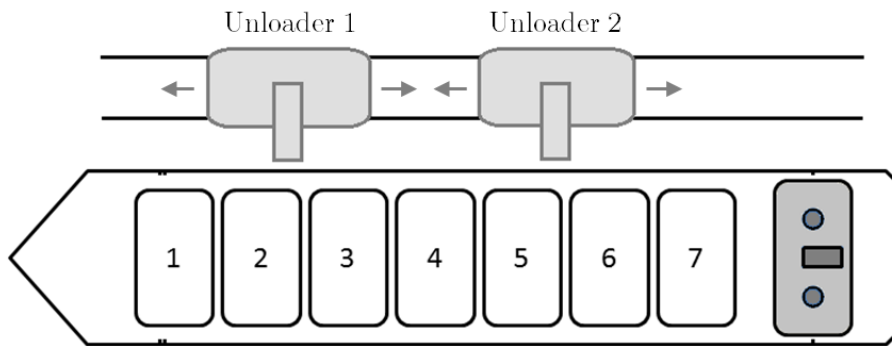

Figure 4: Schematic of the seven-hatch ship unloading procedure in the presence of two operating unloaders.

Fig. 4 provides a sketch of the integration of the second unloading unit, which for simplicity and without loss of generality we will consider to be identical in capacity to the system currently in place. The two unloaders would be placed on a rail system (currently used by the single unloader) that extends far enough laterally such that each unloader could potentially service any of the hatches. This becomes important particularly in case one of the unloaders were to undergo maintenance or repair work. The main aim at this stage is to introduce an efficient unloading procedure for the seven hatch Panamax ships described in subsection 2.2 that would simultaneously reduce the unloading time as much as possible, while maintaining the safety requirements indicated by the deballasating procedures.

A straightforward solution is to allow each unloader to service one side of the ship, for example having the first unloader operate on hatches 1, 2 and 3, while the second unloader extracts materials from hatches 5, 6 and 7. The middle hatch 4 may be accounted for by any of the two unloaders. The result of this exercise is that the unloader which services 4 hatches in phase 1 and 3 hatches in phase 2 will finish faster due to the extended operation time

at higher unloading rates and will therefore be used for the last hatch in cleanup phase. To summarise the above procedure, we find that

$$t_{U1} = \sum_{i=1}^{h_{1p1}} \frac{m_{1i}}{r_{1i}} + \sum_{j=1}^{h_{1p2}} \frac{m_{2j}}{r_{2j}} + \sum_{k=1}^{h_{1c}} \frac{m_{ck}}{r_{ck}}, \quad t_{U2} = \sum_{i=1}^{h_{2p1}} \frac{m_{1i}}{r_{1i}} + \sum_{j=1}^{h_{2p2}} \frac{m_{2j}}{r_{2j}} + \sum_{k=1}^{h_{2c}} \frac{m_{ck}}{r_{ck}}, \quad t_{\bar{U}} = \max(t_{U1}, t_{U2}). \quad (2)$$

Here t_{U1} denotes the unloading time for the first unloader, while t_{U2} is the equivalent quantity for the second unloader. The individual contributions were previously summated in equation (1) from 1 to $h_{p1} = h_{p2} = h_c = 7$. The total number of hatches in equation (2) now acquires an additional index to indicate the number of hatches serviced by each unloader, with h_{1p1} , h_{1p2} , h_{1c} , h_{2p1} , h_{2p2} and h_{2c} taking values of either 3 or 4 as per the described procedure above. The total unloading time for the ship is the time in which one of the unloaders is last to finish operating on the bulk carrier, namely the maximum of the two unloading times t_{U1} and t_{U2} .

Finally, we point out that the issue of maintenance becomes more involved with the introduction of the additional unloader. More concretely, when designing the discrete event simulation model we analyse what the most efficient way to impose long-term maintenance is in order to control costs and additional metrics. Furthermore, we consider the effect of short-term maintenance procedures. These aspects are examined in detail in subsection 3.4.

2.5. Algorithm

In the present subsection we bring all previously discussed elements together and formulate a discrete event simulation model with the aims to

- i. reproduce the unique and complex activity at the port terminal over medium- and long-term periods;
- ii. identify the main contributors to changes in the behaviour of the system;
- iii. test the sensitivity of large scale performance indicators such as costs and berth occupancy to systematic changes in the key parameters (to be identified);
- iv. introduce additional logistical features, such as an upgraded unloading system with multiple active units;
- v. carry out an analysis of the improvements necessary to maximise the utility of such upgrades.

The proposed queueing model replicates the bauxite shipping process at RUSAL by means of integrating the arrival and departure of bauxite bulk carriers together with the material dynamics in the system. A schematic of the simplified model architecture encompassing the systems and sub-systems of the entire port is illustrated in Fig. 5. To account for the convoluted nature of the operations, we formulate a set of simplifications and assumptions directed towards identifying a rigorous theoretical foundation for the discrete event simulation model, while at the same time preserving the realistic nature of the modelled company activity:

1. A known schedule for ship arrival, as well as the appropriate tidal times, are available at the beginning of the year;
2. Bulk carriers can start the journey from Scatterry Island accounting for the correct tidal window, and, if the berth is free, can dock as soon as the tidal window is appropriate;
3. The bulk carrier queue sorting mechanism is solely based on cost reduction considerations, by comparing the demurrage rates of the ships in the queue;

4. Unloading begins immediately after the pre-unloading inspection is passed;
5. All seven hatches of the Panamax ships are assumed to have an identical amount of material and the same internal structure;
6. The unloading rate is a constant value that only changes depending on the digging phase inside each hatch;
7. The unloading rate may also be modified by restrictions based on either conveyor system (the rate of unloading cannot exceed the capacity of the system) or storage facility limitations (full sheds translate to a halting of the unloading process until sufficient material is discharged to re-commence the unloading process);
8. The time for the material to reach the sheds once it is placed on the belts is assumed to be negligible;
9. A shed containing a particular type of bauxite experiencing shortage will not trigger changes in the yearly schedule to account for the lack of material;
10. The discharge rate from the sheds is constant, which neglects the situation of small reserves requiring additional operations and reducing the discharge rate.

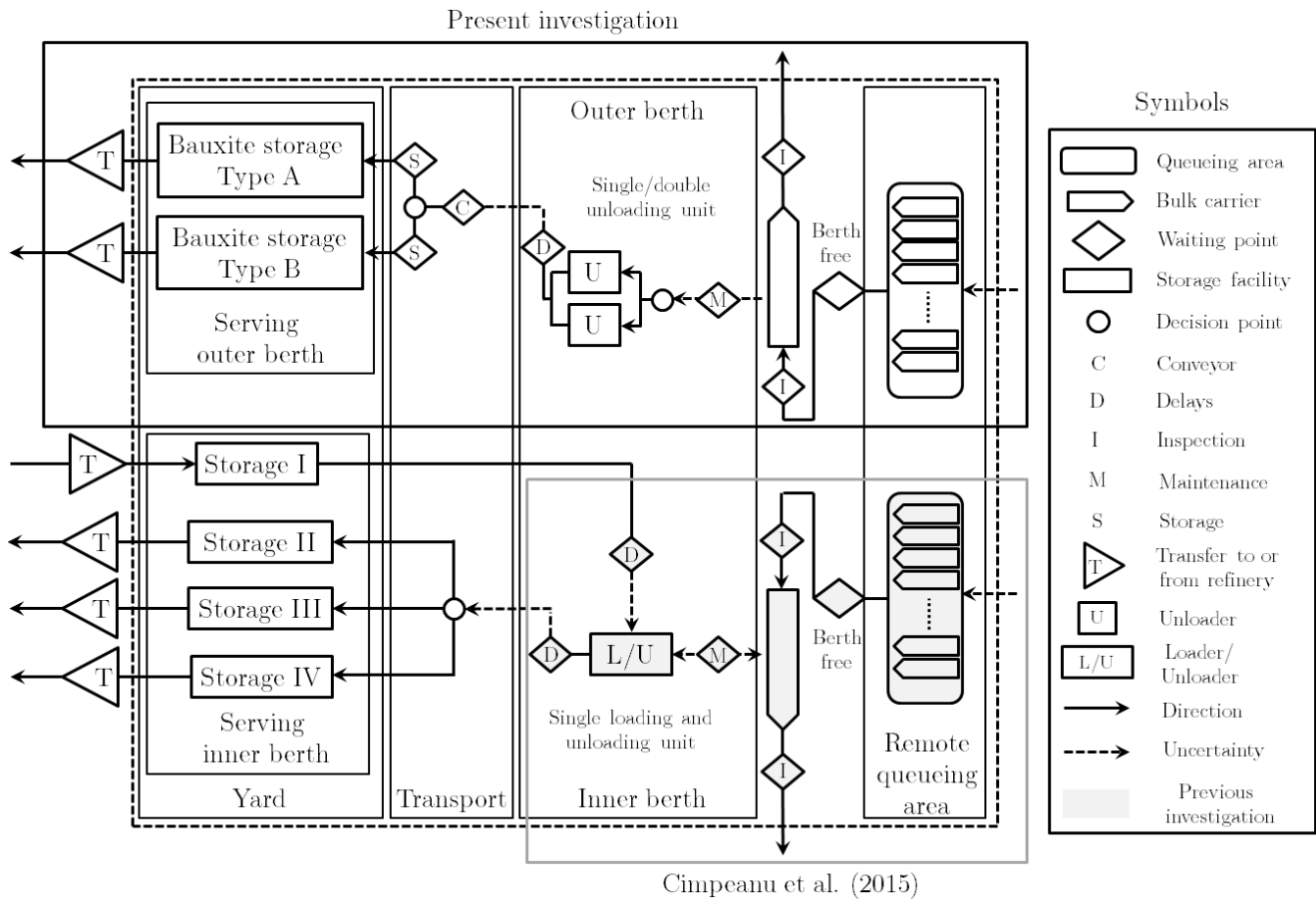

Figure 5: Simplified architecture of the modelled system, highlighting the components and sub-components of the extended port. The regions highlighted in grey (queuing area and inner berth) have been previously examined by Cimpeanu et al. (2015), while the remaining blocks in the upper region (queuing area, outer berth, transport and storage facilities) characterise the constituent elements of the present investigation.

Table 1 introduces the notation for the main steps each bulk carrier undertakes during its local journey within the scope of the present study. In what follows, we use the $(\cdot)^*$ -symbol to refer to quantities that are generated

randomly from empirical distributions of the historical data. The table indicates times during the activity year at which the respective actions take place. Table 2 elaborates on the specific time intervals that affect each particular ship and which will be used for statistical analysis once the entire activity is processed by the simulation model.

Table 1: Event times for bulk carrier i of capacity k_i^* .

a_i^*	Arrive at Scatterry Island
b_i	Depart Scatterry Island
c_i	Arrive at Aughinish port terminal
d_i	Finalise pre-processing operations and begin unloading
e_i	Finish unloading
f_i	Finalise post-processing inspections
g_i	Depart Aughinish port terminal

Apart from the initial schedule itself, the other terms in this table which retain a level of uncertainty are due to either variations in ship size or due to delays (ship-, shore- and weather-related), all of which are sampled from the historical data provided by the company. The underlying empirical (discrete) distributions (see e.g. Fig. 2 on inter-arrival times) incorporate the level of variability typical to each quantity in a realistic manner. In the case of bulk carrier inter-arrival times, we observe a relatively strong spread of the data and also note the presence of outliers. In another example, when inspecting the weather-delay distributions, we find characteristic peaks for either a very small number of hours (due to winds of short duration) or a very large number of hours in case of strong storms or other persistent weather events. Thus each distribution captures the local features of interest, embedding the type of unexpected events encountered in the everyday activity of the port, be they of purely logistic or geographical nature. The direct use of historical data is preferred to the formulation of assumptions about the relevant data structures, such as employing normal or Poisson distributions, which would often be inaccurate given the specialised port activity. We therefore take advantage of the availability of this comprehensive dataset and accurately model a complex system in the domain of port logistics towards practical solutions.

Purely deterministic quantities in the simulation model, such as unloading rates in each phase, demurrage rates, storage capacities and discharge rates from sheds are regarded as constants for each of the two types of bauxite modelled in the system. Finally, the remaining quantities, such as the conveyor capacity, are described by a single global constant that does not change irrespective of the transported material. The main properties of the infrastructure facilities are provided in Table 3, alongside the start and end points of the maintenance periods within the operational year.

Two fundamental building blocks emerge in terms of the algorithmic construction of the proposed discrete simulation model:

- the movement of ships from the queueing point to the berth and, subsequently, their departure from it;
- the detailed logistical operations taking place while the ship is serviced at the port terminal.

Due to the local geographical features of the Shannon estuary, the first of the above shares strong similarities with

Table 2: Bulk carrier activities.

Waiting time at Scatterry	$b_i - a_i^*$
Voyage to port terminal	$T \equiv c_i - b_i$ (constant)
Pre-processing inspection duration	π_i
Delays due to full storage facilities (ShedFull)	s_i
Delays due to material transport facilities (LimitedTransport)	t_i
Delays due to ongoing maintenance (MaintenanceProcedures)	m_i
Shore-related delays	σ_i^*
Ship-related delays	f_i^*
Weather-related delays	ω_i^*
Unloading bulk carrier	$e_i - d_i$
Post-processing inspection duration	$\Pi_i = f_i - e_i$
Start of next tidal window	w_t
Tidal Window Open (TidalWindow)	$w_{t-1} \leq g_i \leq w_{t-1} + TidalWindow$
Depart Aughinish	$g_i = f_i$ if <i>TidalWindow</i> , $g_i = w_t$ otherwise
Time to clear berth	$S \equiv g_i - f_i$ (constant)
Hours counting for demurrage costs	q_i

Table 3: System properties and constraints, with units highlighted in [-]brackets where relevant.

\mathcal{U}	Number of unloading units (one or two)
\mathcal{C}	Conveyor mechanism capacity [tons/hour]
\mathcal{S}_j	Shed capacity [tons], $j = A, B$
\mathcal{D}_j	Discharge rate from each shed [tons/hour], $j = A, B$
$\mathcal{M}_j(t)$	Raw material inside each shed [tons] at a given time t , $j = A, B$
μ_s	Start of maintenance period, $s = 1, \dots$
μ_e	End of maintenance period, $e = 1, \dots$

the previous study of Cimpeanu et al. (2015). More specifically, ships being serviced at either the inner or the outer berth, irrespective of their size, construction and transported material, are restricted by the same tidal windows in order to ensure the safety of the logistical operations at the port terminal. In both circumstances Scatterry Island serves as the natural queueing point in the system. We thus refer to Algorithm 1 of the respective study for details on how tidal windows affect the ship movement up to the port terminal. A consistent variable naming scheme has been selected to ensure a suitable comparison.

In what follows we concentrate on the main contributions of the present investigation, previously introduced in Section 2. Algorithm 1 addresses the components of the discrete event simulation model summarising the port activities outlined in the previous subsections in pseudocode form.

Inspection procedures of a set duration π_i are required before the unloading process begins. If, after this step

Data: Global simulation data for ship i : type $j \in A, B$, $c_i, k_i^*, \sigma_i^*, f_i^*, \omega_i^*, \pi_i, \Pi_i, \mathcal{U}, \mathcal{C}, \mathcal{S}_j, \mathcal{D}_j, \mathcal{M}_j(t), \mu_i$

Result: Dynamics of bulk carrier i while at the port terminal: g_i , performance indicators

```

InheritGlobalSimulationData();
RetrieveBerthingTime():  $c_i$  (see Algorithm 1 in
  Cimpeanu et al. (2015));
InspectShipPreprocessing():  $\pi_i$ ;
if  $\mu_s \leq c_i \leq \mu_e \forall \{s, e\}$  (MaintenanceProcedures) then
  |  $m_i = \mu_e - c_i$ ;
  |  $q_i = q_i + m_i$ ;
end
RetrieveShipType():  $j$ ;
if  $M_j(t) + k_i^* \geq \mathcal{S}_j$  (ShedFull) then
  |  $s_i = (M_j(t) + k_i^* - \mathcal{S}_j) / \mathcal{D}_j$ ;
  |  $q_i = q_i + s_i$ ;
end
ComputeUnloadingTime( $\mathcal{U}, k_i^*, r_{xh}, m_x$ ):  $T_{\mathcal{I}}$ ;
if  $\mathcal{U} = 2$  (AdditionalUnloader) then
  | for  $x \in \{1, 2, c\}$  do
    | for  $h = 1 \dots 7$  do
      | for  $h = 1 \dots 7$  do
        | if  $h < 7$  then
          | |  $r_{xh} = 2.0 \cdot r_{xh}$  (MaxLoadingFactor);
          | end
        |  $r_{x7} = \iota_x \cdot r_{x7}$  (IntermediateFactor);
        | end
      | end
    | end
  | end
end
for  $x \in \{1, 2, c\}$  do
  | for  $h = 1 \dots 7$  do
    | if  $r_{xh} > \mathcal{C}$  (LimitedTransport) then
      | |  $LimitedTransportSwitch = 1$ ;
      | |  $r_{xh} = \mathcal{C}$ ;
    | end
  | end
end
if LimitedTransportSwitch then
  | ComputeUnloadingTime( $\mathcal{U}, k_i^*, r_{xh}, m_x$ ):  $T_{\mathcal{C}}$ ;
  |  $t_i = T_{\mathcal{C}} - T_{\mathcal{I}}$ ;
  |  $q_i = q_i + T_{\mathcal{C}}$ ;
end
else
  |  $q_i = q_i + T_{\mathcal{I}}$ ;
end
AddDelays():  $q_i = q_i + \sigma_i^* + f_i^* + \omega_i^*$ ;
InspectShipPostprocessing():  $q_i = q_i + \Pi_i$ ;
LeaveDuringSuitableTide:  $g_i$ ;
UpdateGlobalSimulationData();
ComputeIndividualPerformanceIndicators();
UpdateGlobalPerformanceIndicators();
DataAnalysis;
Visualisation;

```

Algorithm 1: Individual bulk carrier processing at berth - simulation pseudocode.

has taken place, the port terminal is undergoing maintenance procedures, the bulk carrier must remain unserved until a functional unloader is available. In the following subsections we expand on how a suitable maintenance configuration may avoid such delays when using multiple unloading units. The next verification step relates to the amount of material $M_j(t)$ in the appropriate shed, where j denotes material of type either A or B and t refers to the point in time within the operational year at which the contents of the respective shed are examined. Should the storage limit in the relevant unit be under pressure, the number of hours required to provide the necessary space for the material in the serviced bulk carrier is calculated and the unloading start time postponed due to storage-related delays.

Once the inspection and auxiliary equipment verifications are finalised, the next stage of the servicing progression

is dedicated to the unloading procedure. This step requires the most substantial amount of time within the sequence of operations involved in the processing of any individual bulk carrier, with the number of unloading units strongly influencing the implementation. The transition from one to two unloading facilities entails a conversion of the underlying model from a single-server to a two-server queueing system with dedicated modelling in view of the specific bulk carrier properties highlighted in subsections 2.2 and 2.4. Therein formulas (1) and (2) have been provided to calculate the amount of time required to empty the bulk carriers with the specified internal structure. These are applicable in cases in which the conveyor capacity \mathcal{C} is higher than the digging rate in any of the three phases and does not form a bottleneck in the unloading process. Particularly when a second unloader is present, the overall digging rate may however exceed this operational capacity and suitable adjustments are necessary. In these circumstances, the overall unloading rate is re-computed and may be approximated by doubling the single unloading rate while the first six hatches are serviced in parallel in each phase, three by each unloader. The seventh hatch would be emptied either with one of the other hatches in a subsequent phase, with the exception of the clean-up of the final hatch. In each of these events a rate of $\iota_x < 2.0$, where $x \in \{1, 2, c\}$ is computed based on the ship capacity, internal hatch design and corresponding unloading rates. Should the original unloading rates in the case of a single unloader or the recomputed unloading rates in the case of the second unloader exceed the conveyor mechanism capacity \mathcal{C} , the latter value acts as an upper limit and as the redefined operational unloading rate for the respective phase, effectively increasing the total unloading time when servicing the bulk carrier. The material is ultimately transferred to the appropriate storage facility (with an associated discharge rate) and the quantity of bauxite within each shed is updated dynamically based on the times of the discrete events involved in the bulk carrier processing.

At this point we underline that, as highlighted in the introductory subsection 1.1, typically material transfer and storage refers to the transportation of containers with units such as trucks and the stacking of these containers in dedicated areas within the port. A conveyor system serving multiple unloading units with a direct pipeline from the berth to specialised raw material storage facilities, together with associated discharge operations, are new additions of the present study in terms of modelling of port logistics, inspired by the local challenges of the analysed activity.

Any other type of delays (shore-, ship- or weather-related) generated from the inverse cumulative probability distributions based on the historical datasets for each ship type are then added once unloading is finished. Upon post-unloading inspection procedures of duration Π_i and the arrival of a suitable tidal window, the bulk carrier leaves the berth and the processing of the next scheduled vessel commences in an analogous manner to the procedure described above.

With all prerequisites in place, the set of bulk carriers is introduced into the system, with each ship undergoing the required steps. Within these stages, a dynamic dataset pertaining to each ship is gradually compiled, containing time-dependent quantities (unknown at the start of the simulation), such as queueing times. We note that each component in the transportation chain of the bauxite from the ships to the storage facilities and further into the refinery may have a (potentially strong) effect on the individual dynamics of each ship, with delays also propagating further in the queue. From the contributions of each bulk carrier, associated costs, berth occupancy and queueing times are gathered and accumulated into aggregate amounts, ultimately providing an insight into the performance of the system on longer timescales. The role of the proposed model as a strategic rather than a short-term decision

making support tool reinforces the adoption of a discrete event simulation approach. Given that the modelled system includes significant events such as long-term maintenance procedures that occur only once every few months, the duration of a full operational year as the relevant time window is well justified. The complexity of the model (including multiple sub-systems), as well as the non-trivial empirical distributions underlying features from inter-arrival times (recall Fig. 2) to the various types of delays, makes fitting analytical distributions either impossible or detrimental to the accuracy of the model (see also discussion on this topic by van Vianen et al. (2014)). All previous arguments favour a simulation modelling approach. We underline however that theoretical random variable estimation approaches have been used successfully for short-term (tactical) scenarios or integrated in larger scale systems and we refer to the investigation of Carteni and De Luca (2012) for a rigorous comparison of these techniques and an analysis of their scope and efficiency.

The discrete event simulation model discussed in the previous paragraphs is implemented and used extensively in the form of a computational platform designed to facilitate changes in port terminal equipment, as well as explorations of the parameter space.

3. Results and analysis

The algorithm and its underlying model are used in the present section in order to investigate the performance of the modelled system with the aim of informing additional equipment modifications and strategic decision-making on a longer timescale. We first validate the proposed framework in subsection 3.1 by comparing the simulated activity to that of a typical operational year in the relevant parts of the refinery and port terminal.

3.1. Validation

Using the algorithm described in the previous section, simulations of the yearly activity in the target sections of the refinery and port terminal are carried out, producing detailed information on the key performance indicators. All relevant initial data (demurrage rates, unloading rates in each phase, conveyor and shed capacity etc.) has been provided by the company. Furthermore, based on datasets provided by RUSAL Aughinish, we generate information such as bulk carrier capacities and delays, by sampling from empirical distributions. The information queried in these datasets, referred to as the historical data, encompasses the activity at the port terminal and subsequent points in the system during the last operational year, i.e. the most recent 365 day period for which complete data was available. At a mean level, we expect to reproduce the large scale quantitative features of the system. However we also aim to quantify the level of variability of the investigated activities. To this end, the results in the present subsection are summarised from a set of 50000 simulations, which provide a reliable account of the activity year statistics. The efficiency of the constructed computational framework ensures that a single repetition takes less than 0.05 seconds on a 2.5 GHz i5-3210M dual-core processor with 8GB of RAM, despite the complexity of the modelled system. Based on analysing the dynamics of cumulative moving averages, the mean values of the performance descriptors of interest no longer vary beyond $\mathcal{O}(10^2)$ samples. The additional computational effort has been invested in order to obtain a very clean description of the confidence intervals, as well as the structure of the result distributions, thus facilitating a deeper understanding of the underlying behaviour of the system.

The values reported in section 3 are normalised with respect to the values in the reference year. Where differentiation between bulk carrier types is required or is beneficial, the results are scaled in terms of the values for Type A ships. Any exceptions are acknowledged when discussing the points in question. Most importantly, we note that for the data in all subsequent figures and tables, a value of 1 corresponds to the actual value in the historical dataset for the respective variable and, in the context of the validation process, the target value for the discrete event simulation model.

We employ the two-sample Kolmogorov-Smirnov test in order to assess the accuracy of the discrete sampling procedure based on the constructed inverse cumulative probability distributions from the provided datasets. Such is the case of the ship capacities, for which the historical distributions have already been highlighted in Fig. 2. An example fleet obtained by the sampling procedure is depicted in Fig. 6, with the historical data shown in the top panels and the simulation data presented in the bottom panels. This verification, highlighted in Table 4, indicates that the obtained bulk carrier capacity distributions, with p -values of 0.832 and 0.877 (significantly higher than the typical mark of 0.05), are statistically no different from the historical datasets and hence describe an accurate representation thereof.

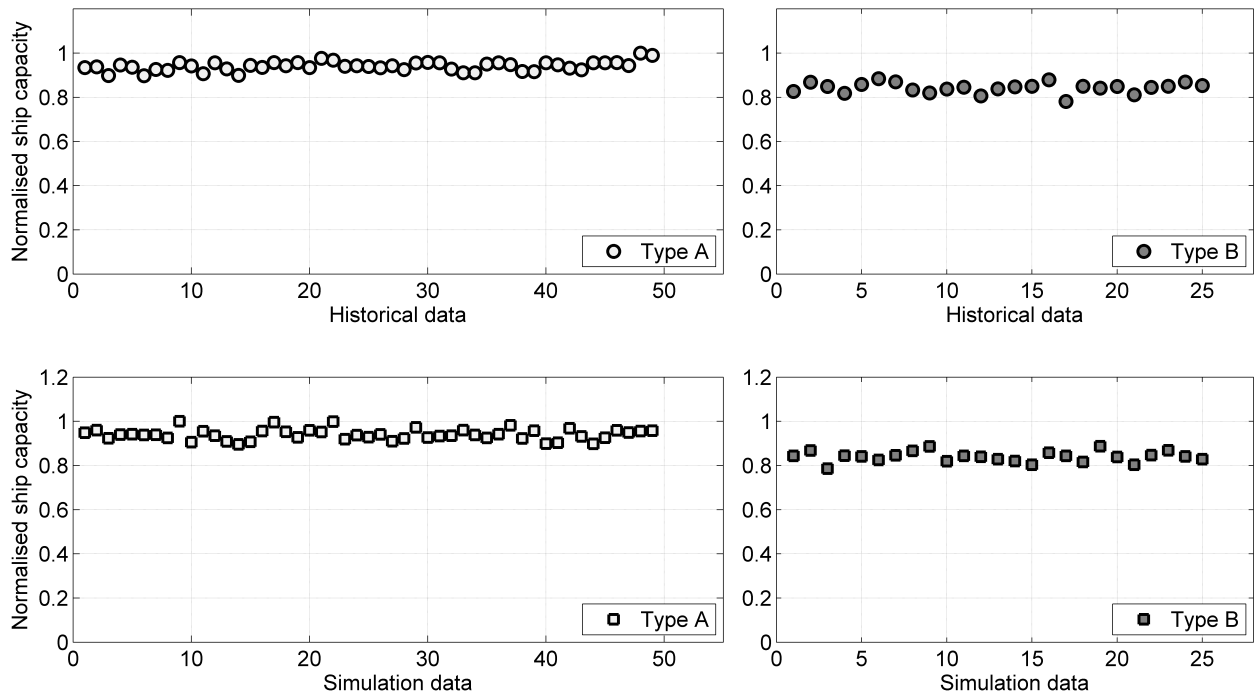

Figure 6: Comparison between normalised ship capacity distributions, with the historical dataset (above) illustrated alongside sample simulation data (below) produced from distribution sampling, for both Type A bulk carriers (left) and Type B bulk carriers (right).

Fig. 7 displays the queueing hours accumulated by each bulk carrier in the same format. The noticeable features, apart again from the similarity of the historical and simulation data (quantified later in this discussion), are the fact that most ships accrue a non-zero queueing time and the emergence of a certain pattern of increases followed by decreases within a timescale spanning the processing duration of several bulk carriers. This property was found to be related to the long-term maintenance procedures, during which ships queue at Scatterry Island and accumulate queueing hours resulting in local peaks. As soon as the effects of the maintenance disappear, the

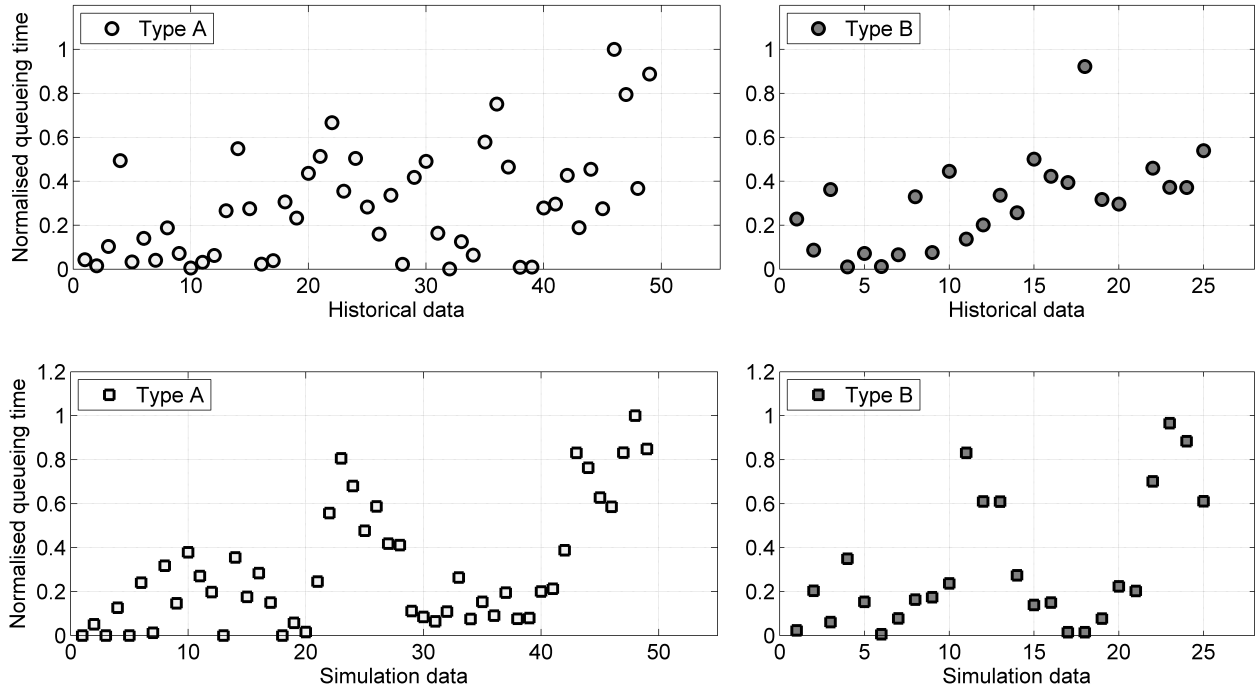

Figure 7: Comparison between normalised queueing hour distributions, with the historical dataset (above) illustrated alongside sample simulation data (below) resulting from the discrete event model, for both Type A bulk carriers (left) and Type B bulk carriers (right).

Table 4: Distribution validation via the two-sample Kolmogorov-Smirnov test for bulk carrier capacity (input created from historical dataset distribution sampling) and queueing hours (model output), with the historical dataset as reference.

	Type A ships	Type B ships
Distribution	p -value	p -value
Bulk carrier capacity	0.832	0.877
Queueing hours	0.147	0.237

system is regularised to the desired state in which the normalised queueing time reduces significantly. Even in such a case however, note that the potential impact of the concurrent arrival of multiple ships due to the variability in inter-arrival times still has an important effect on queueing hours and hence demurrage costs. The distributions depicted in Fig. 7 have again been compared with the historical dataset in terms of the two-sample Kolmogorov-Smirnov test in Table 4, with p -values of 0.147 and 0.237, respectively. As opposed to the bulk carrier capacities, which are a form of purely initial data directly sampled from the historical distributions, the queueing hours describe the behaviour of the system at the end of the simulation and thus the quantities in question are subjected to the entire variability in the system. Thus obtaining p -values larger than 0.05 indicates that the model reproduces the activity of the real life system accurately.

An example of material dynamics simulation within each shed is illustrated in Fig. 8, revealing the balance between the material being introduced in the shed following bauxite unloading procedures at the port terminal and the discharge of material to the next processes in the refinery. The symbols (light and dark grey dots) represent the amount of material present in the shed at the end of the unloading of each ship during the respective activity year. The material quantity is normalised with respect to the total capacity of each shed. Note that the shed capacity

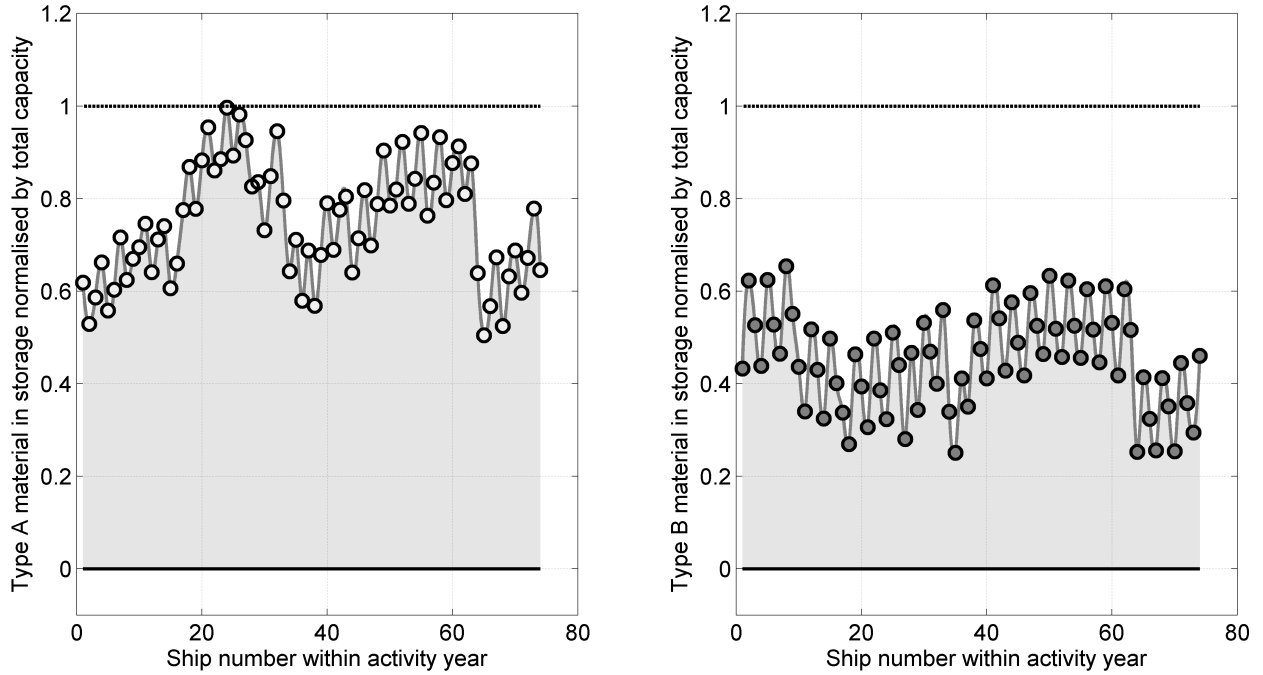

Figure 8: Example simulated material dynamics within the storage facilities. The symbols indicate the amount of bauxite found in the sheds observed after finalising the unloading procedure for each bulk carrier (Type A - left and Type B - right). The horizontal axis extends over the total number of ships during one activity year.

in the respective realisation is almost reached (left panel). This would cause a delay in the unloading process for a duration up to when enough space is created for the bauxite to be transported from the outer berth. In ideal circumstances, the bulk carriers arriving at berth would have to alternate in proportion to the required bauxite quantities within the period of activity, so as to reduce the pressure on any of the two sheds. Large queues of bulk carriers of the same type of material cause significant delays, due to the discharge rates being unable to account for the inflow of bauxite in the storage facilities. We emphasise that such an in-depth analysis of the material dynamics in the system and its effects has, to our knowledge, not been addressed in this level of detail in previous investigations on this topic.

In Fig. 9 we present a bar plot of the normalised average unloading times (both overall and separated into ship types) of the data in the 90% confidence interval, as well as its limit values. While the unloading rates are set as constant values as an initial parameter in the simulation, the ship capacities, as well as all types of delays (ship-, shore- and weather-related) introduce variability in this quantity, which measures the time from when the ship passes its pre-unload inspection to when post-unload inspection begins. The difference between the simulated and actual means is below 2%, suggesting good agreement with the historical dataset.

The normalised overall costs are one of the most important large scale performance indicators in the system. Fig. 10 illustrates the summary of this study, with the distribution of the overall costs shown in Fig. 10a, as well as a differentiation based on ship types presented in Fig. 10b. We notice a positively skewed cost distribution, with a 90% confidence interval extending from 65% of the historical value up to approximately 200% of the real life costs. This relatively strong variation suggests that employing a simulation model with embedded variability and conducting a statistical analysis of the resulting dynamics was indeed appropriate, as the real life system is

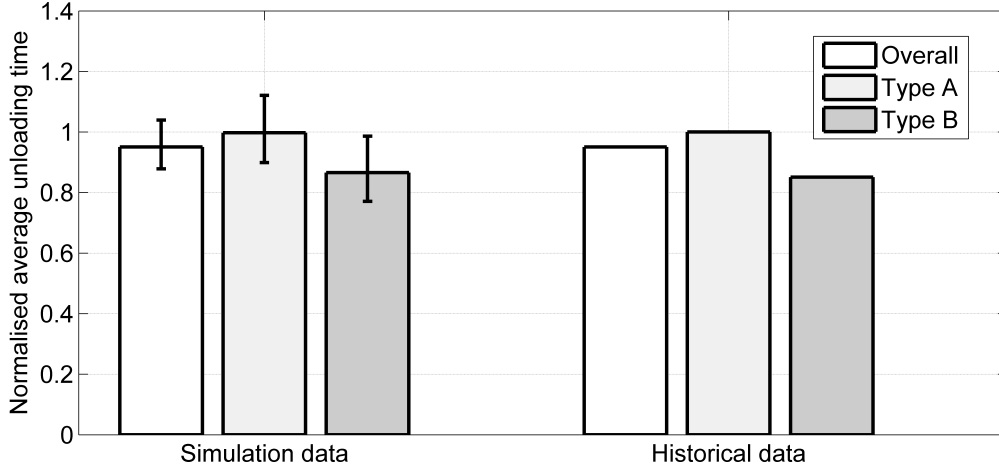
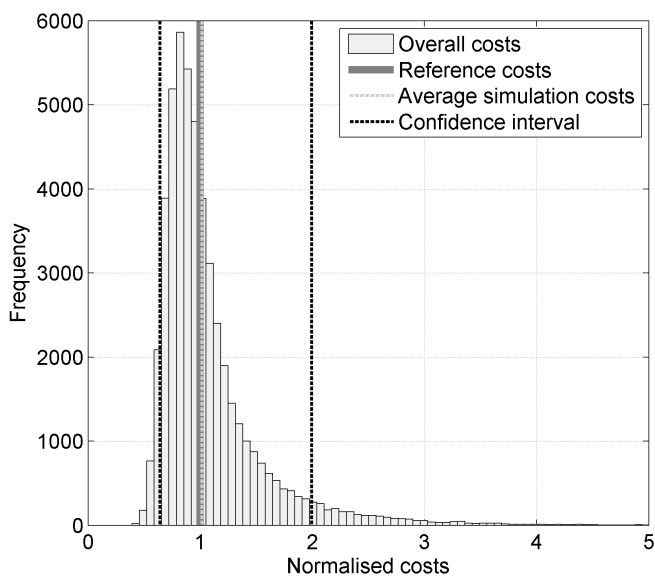

Figure 9: Average unloading times for each type of bulk carrier, as well as average unloading times (white), comparing the simulation data (left) to the historical data for the reference activity year (right). The quantities are normalised with respect to the historical values for Type A bulk carriers, the largest in the fleet. The bars indicate the minimum and maximum of the 90% confidence interval.

subjected to a similar degree of uncertainty as the model itself. Whereas the difference between the means of the historical dataset and the simulations is negligible, we underline that the simulated data evolves a peak which is visibly lower than the mean. The positively skewed distribution is explained through the persistence of rare events in the system. As already pointed out, long delays occurring either through maintenance or unforeseen events tend to affect not only the ship presently at berth or in the front of the queue, but rather a large number of bulk carriers. The frequent arrival of ships at Scattery Island translates to accumulated queues and thus it is very likely that an overlap of undesirable factors (such as a long weather delay followed by a long-term maintenance period) causes substantially larger queuing times directly translating into increased demurrage costs. As can be seen in Fig. 10a, in the most extreme cases, such a behaviour may result in cost increases of up to 300%. In practice, such issues may be ameliorated by means of human intervention, ranging from changes in scheduling to modifications of the queue prioritisation system (cost-based in the model). However, this requires policies tailored on a case-by-case basis and may not facilitate interpretation from a larger scale perspective. Therefore, instead, we study the system within confidence intervals and limit the influence of strong outliers from a strategic point of view.

A similar study is performed in the case of berth occupancy, as presented in Fig. 11. The distribution in this case is approximately symmetric and shows only minor variation (less than 4% on either side) around the mean. Referring to the direct comparison between the simulated and historical data, Fig. 11b reveals a slight underestimation of the contribution of Type A ships to the berth occupancy (less than 5%). This is however balanced by the berth occupancy for Type B ships, with the overall mean being virtually indistinguishable from the historical value.

The remaining large scale performance indicators can be described in a straightforward manner. As the queuing hour values underlie the computation of the costs, their behaviour is very similar in terms of both averages and distribution behaviours. Finally, the total material unloaded (a fixed quantity given by the ship capacities during the activity year) experiences almost no variation. This quantity is expected to suffer more significant modifications in cases when not all bulk carriers in the shipping schedule can be processed. This currently happens only in the



(a) Normalised cost histogram.

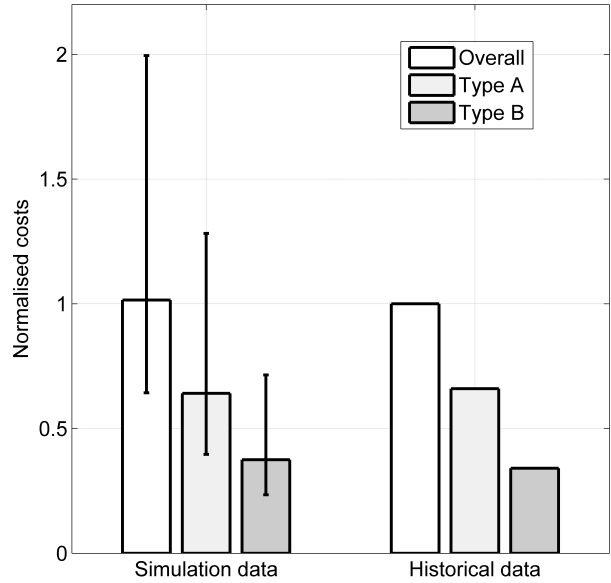

(b) Mean cost comparison.

Figure 10: Demurrage cost results produced by each type of bulk carrier and overall, compared to the historical data from the reference year. (a) In the histogram, the dark grey continuous vertical line indicates the value for the reference year, while the light grey dotted line illustrates the mean costs, as resulting from the simulation model. Black dashed vertical lines indicate the limits of the 90% confidence interval. (b) The results are presented both overall and for each type of bulk carrier, with bars denoting the limits of the 90% confidence interval.

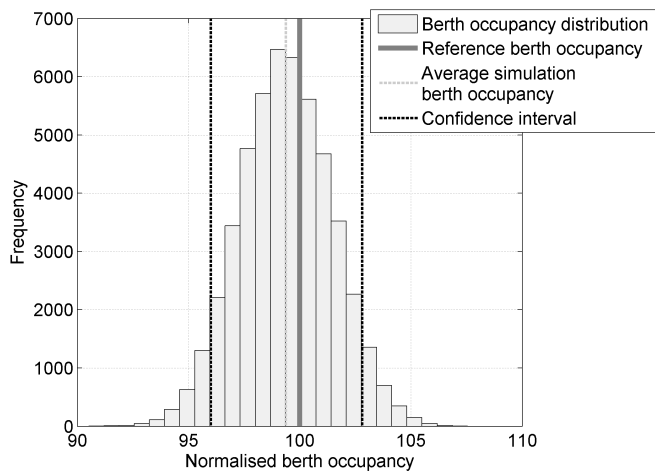

(a) Normalised berth occupancy histogram.

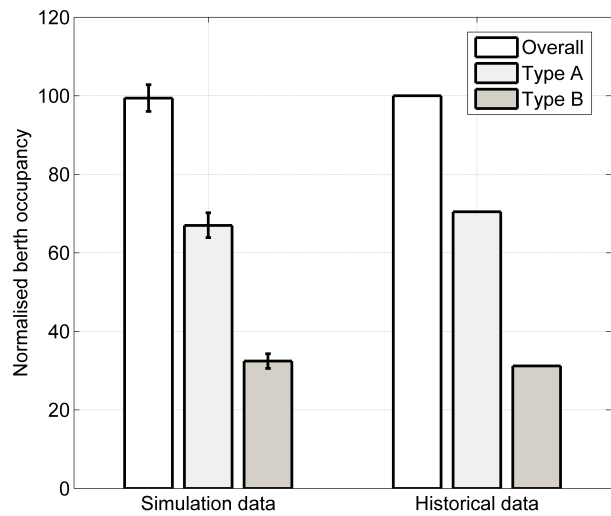

(b) Mean berth occupancy comparison.

Figure 11: Berth occupancy results produced by each type of bulk carrier and overall, compared to the historical data from the reference year. (a) In the histogram, the dark grey continuous vertical line indicates the historical value, while the light grey dotted line illustrates the mean berth occupancy, as resulting from the simulation model. Black dashed vertical lines indicate the limits of the 90% confidence interval. (b) The results are presented both overall and for each type of bulk carrier, with bars denoting the limits of the 90% confidence interval.

Table 5: Discrete event simulation model validation summary. Comparison of results for large scale performance descriptors (costs, berth occupancy, queueing hours and unloaded material) with the historical dataset.

Indicator	Mean L^1 error norm across simulations	Coefficient of variation	Error (%) between simulation mean and reference value
Costs	0.217506	0.099731	1.498784
Berth occupancy	0.014568	0.019503	0.614618
Queueing hours	0.201136	0.037740	4.259393
Unloaded material	0.012328	0.002229	1.147650

extremely rare cases of the occurrence of clusters of maintenance periods and severe delays.

Previous discussion of the system is further complemented in a quantitative manner by means of introducing a standard choice of norm (the L^1 -norm, defined in eq. 3) to quantify the mean absolute percentage error. With Q defined as a quantity of interest, we introduce Q_h as notation for its value in the historical data and $Q_s(i)$ as the value of the respective quantity obtained in the i^{th} simulation. With an averaging factor we then obtain

$$N(i, Q_s, Q_h) = \frac{|Q_s(i) - Q_h|}{Q_h}, \quad \bar{L}^1(Q) = \frac{1}{n} \sum_{i=1}^n N(i, Q_s, Q_h). \quad (3)$$

Furthermore, the percentage error between the mean value of the simulations and the historical values is reported in terms of

$$E(Q) = \left| 1 - \left(\frac{1}{n} \sum_{i=1}^n \frac{Q_s(i)}{Q_h} \right) \right| \cdot 100. \quad (4)$$

Table 5 summarises our findings for each of the four performance descriptors, indicating the results for the error norm as defined in eq. (3), the coefficient of variation and finally, the mean percentage error as presented in eq. (4). The similarity between queueing time and cost behaviour is noticeable due to their direct dependence through the lay time variable. Presented in Fig. 10, the underlying distribution explains the larger discrepancy in the L^1 -norm as compared to the other studied variables. The discrepancy is comparable to the difference between the historical value and the peak obtained in the simulated dataset. The variability in berth occupancy and material unloaded is significantly smaller. Finally, we note that the mean percentage error $E(Q)$ is very small, 4% for queueing hours and approximately 1% for all other performance descriptors.

Following a comprehensive analysis of both qualitative and quantitative features, we have established agreement with historical values in a simulation model with no fitting parameters. Furthermore, modelling the uncertainty in the system allowed us to investigate the type of phenomena causing deviations from a typical operational year.

3.2. Single unloader

The extensive validation study established a reliable performance of the discrete event simulation model. In addition, the level of variability of the uncertainty factors indicates that modifications of key parameters could produce substantial changes. The investigation in the present subsection identifies such features, allowing us to use the developed methodology in order to establish strategic directions for performance improvement.

While the number of variables that could be studied exceeds 100, we concentrate on eight constituents of the model. The reason behind this choice lies in the level of control that the company can exert onto these features in

real life. For example, while an interesting study, the severity or regularity of weather-related delays could not be manipulated in future activity years. However concrete efforts can be made in the case of several logistical elements, as well as shore-related activities. These variables are:

- i. the regularisation of the inter-arrival time of the bulk carriers;
- ii. shore-related delays, the only type of delays originating from the activity at the refinery and port terminal;
- iii. pre-unload inspection times;
- iv. storage facility capacities;
- v. conveyor system capacity;
- vi. discharge rates from the sheds;
- vii. unloading rate in all phases (simultaneously);
- viii. full equipment upgrade: unloading rates, conveyor capacity, shed capacity and discharge rates modified as a joint variable.

In the following paragraphs these parameters are referred to as control variables. The test scenarios we perform involve a variation of these control parameters from 50% to 150% of their original values. By convention, an increase in the control variable relates to an improvement in performance, such that for example setting the conveyor system capacity at 1.1 corresponds to a 10% increase in capacity, while for shore-related delays this actually indicates a reduction in the mean shore-related delay values by the same percentage. Similarly, a 1.1 value for the inter-arrival time relates to a decrease in the variability, which can be controlled during the Monte Carlo sampling process by the given factor. The limits of the interval have been chosen as part of the consultation process with the company and are regarded as realistically attainable targets for the chosen elements.

The test procedure for each of the selected scenarios entails a series of 10000 realisations of the yearly activity. Therefore 110000 iterations of the model underlie the investigation of each control variable, with 880000 runs generated in total. During the respective realisations, the control variables are modified as explained in the previous paragraph, while all other parameters are maintained at the levels from the historical dataset. This method determines the influence of each individual factor on the large scale performance indicators (costs, berth occupancy, queueing hours and unloaded material).

Figures 12-13 summarise our findings. The results are grouped into two separate figures, with the first group of four control variables producing a more limited variation of the performance indicator. This is in contrast to the impact of the final four control variables, which in addition to the notable discrepancy in the scales, also require the use of insets in order to highlight desired features in the results.

Fig. 12 illustrates the effect of the first four control variables (regularisation of the schedule, shore-related delays, pre-unload inspection duration and shed capacities). Queueing hours and costs exhibit, as expected, a very similar behaviour. Pre-unload inspections produce an approximately linear variation in these performance indicators and overall determine the smallest change from the tested control variables, with an impact of less than 10% in reference to the historical values. Similarly, shore-related delays determine a reduction in costs of only 15%, while a significant increase in shore-related delays causes a cost increase of 24%. By contrast, a more irregular shipping schedule would increase costs by 40%, while a reduced shed capacity would more than double queueing hours and hence costs.

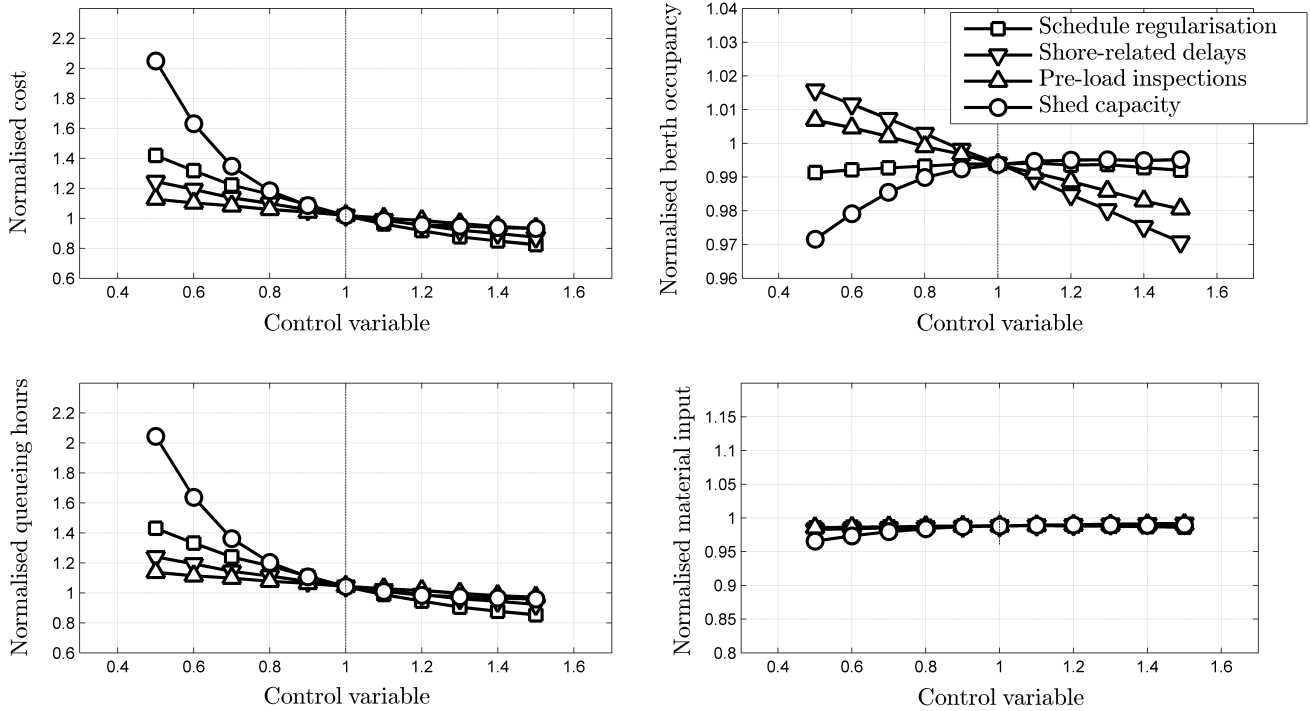

Figure 12: Summary of the impact of parameter variation on large scale performance indicators in the case of one operating unloader - normalised demurrage costs (top left), normalised berth occupancy (top right), normalised queueing hours (bottom left) and normalised unloaded material (bottom right).

The berth occupancy exhibits a more interesting dynamics across the parameter study. Shore-related delays directly affect berth time and a change in this variable imposes a proportional effect on the berth occupancy variation. While only a subset of the ships are affected by shore-related delays, each individual bulk carrier requires pre-unload inspection, with a total amount of hours spent on inspections exceeding the previously mentioned delays. Since these time intervals also translate to an increased berthing period for the ships, it is natural to find that pre-unload inspections follow a similar, yet stronger pattern. Schedule regularisation produces almost no variation (less than 0.25% in range). In terms of shed capacity, we first emphasise that increasing the current capacity would not be beneficial in terms of processing a fleet with the modelled properties. Interestingly, a decrease in the shed capacity decreases the berth occupancy by a small factor. This is due to a technical aspect of the model, in which we consider the material unloaded from the ships as being in temporary storage once it lies on the conveyor system and in smaller storage units outside the sheds. Thus, once unloaded, the bulk carrier is inspected and then leaves berth, giving rise to a long interval of time between its departure and the arrival of the next ship, interval in which the berth is considered empty, therefore contributing to a decrease in berth occupancy. An alternative policy would be to disregard the possibility of temporary storage and require the bulk carrier to remain at berth while a slowed down unloading process takes place. By contrast, this choice would increase berth occupancy. Note however the the total window of variation in berth occupancy does not exceed 5%, hence the discussed variables only produce a marginal level of impact on the berth occupancy on a larger scale. Finally, we find that the amount of material is unaffected unless a significant reduction in shed capacity is prescribed.

Fig. 13 describes the impact of the remaining four control variables. In terms of costs and queueing hours, an

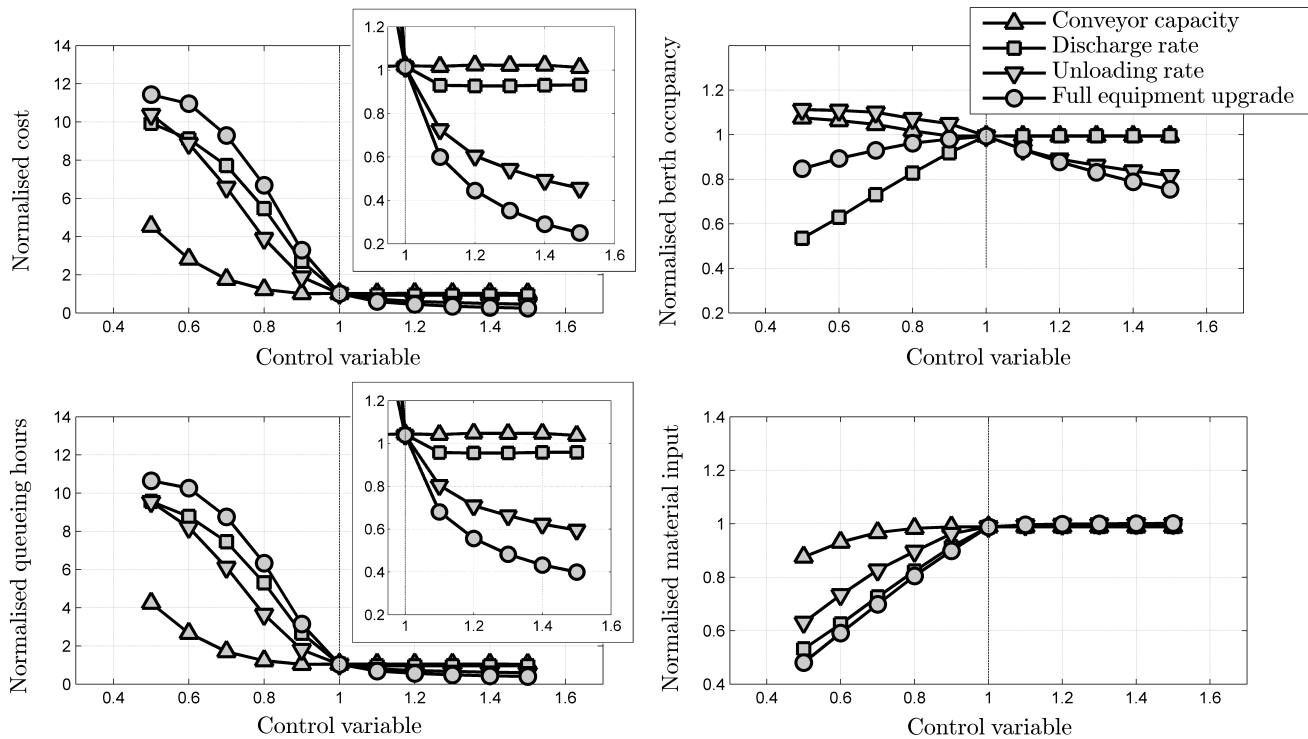

Figure 13: Summary of the impact of parameter variation on large scale performance indicators in the case of one operating unloader - normalised demurrage costs (top left), normalised berth occupancy (top right), normalised queueing hours (bottom left) and normalised unloaded material (bottom right).

increase in the conveyor capacity does not present substantial advantages, since the current amount of material to be processed during an operational year is serviced conveniently by the present system. On the other hand, should the transport capacity decrease, there is a strong negative effect on the performance, with a 50% decrease in the conveyor capacity leading to an increase in costs by more than a factor of four, significantly higher than all previous control variables discussed with the aid of Fig. 12. In such a case, the amount of material unloaded also decreases by 16% during the respective operational year, as not all ships are processed within the desired window of activity. The delays caused by reduced transportation capabilities also affect the time spent at berth by each bulk carrier, leading to an increase of 10% in berth occupancy.

Enhancing the discharge rate of material from the sheds improves the performance of the system, with a 10% increase in this control variable contributing to a 7% cost decrease as compared to the reference value. However no further benefits are observed beyond this point. On the other hand, a reduction of the current rates has severe effects, both in terms of material unloaded, decreasing proportionally with the discharge rate down to almost a half of the original amount, as well as costs. An almost tenfold cost level is reached in the case of a strong reduction in the discharge rate. This is due to a very large number of bulk carriers awaiting in the queue for material space to become available in the sheds before berthing. Berth occupancy also decreases considerably, the berth being empty in between ship movements during the intervals when slowed down discharge would be occurring.

The unloading rate is the pivotal parameter responsible for cost reduction. An increase in its performance leads to substantial gains in terms of both costs (down to almost half when increasing the unloading rate by 50% and

with sustained effects even at smaller improvement rates) and berth occupancy (down by 18% in the best case scenario). A decrease in the unloading performance produces similar cost impacts to the discharge rate study with a queueing hour and cost total of approximately ten times the historical amount. The berth occupancy rises by 5 – 10% depending on the severity of the decrease, as bulk carriers remain longer at berth while a slower unloading takes place.

In a novel exploration, we also combine the overall equipment performance into a joint variable comprised of simultaneous modifications in unloading rates, conveyor capacity, shed capacity and discharge rates, which magnifies the discussed features within the entire parameter space. The benefit in terms of reduction in queueing hours and costs are increased by a further 50% as compared to the case when only the unloading rate is improved, while any negative alterations are further enhanced by 10 – 20%. Interestingly, the berth occupancy still decreases, however not as strongly as in the case when solely the discharge rate is responsible for the variation. The slowing down of the other components in the system amount to a longer time spent at berth in order to service each bulk carrier.

The study in the present subsection indicates the unloading rate as the critical factor responsible for potential performance growth, lowering costs down to 45% of the historical value. A swifter processing of the ships limits the impact of outliers affecting the system, and even in such a case, significantly reduces the effects of such an occurrence in terms of the number of ships in the queue affected. This can be complemented by improving the transport and storage facilities, lowering costs down to 25% of the original value. Thus we conclude that the investment in an additional unloading unit, as introduced in subsection 2.4, offers the best strategic direction.

3.3. Additional unloader

One of the most salient aspects of the present paper is the introduction of a large scale logistical modification in the form of an unloading mechanism with two separate unloading units. A thorough examination of the parameter space in the previous subsection highlighted the central role of the unloading process in the modelled system. Such a large scale strategic expansion is the natural next step in our study.

For a first comparison between unloading times with one or two units, t_U and $t_{\bar{U}}$, we refer back to eq. (1) and eq. (2), respectively, for a definition of the individual times required to process an individual bulk carrier. Simple algebraic operations in light of the quantities in the historical dataset lead to $t_{\bar{U}}/t_U = 0.5159$ and $(t_{\bar{U}} + \bar{t}_{\text{delays}})/(t_U + \bar{t}_{\text{delays}}) = 0.6166$, where \bar{t}_{delays} represents the average number of total delays (shore-, ship- and weather-related) per ship as provided in the historical dataset. This entails that the effective unloading time when using a second identical unloading unit is reduced down to 61.66% of its original value. Hence we already anticipate a strong effect of the upgraded unloading mechanism.

The introduction of a second unloading unit poses an additional challenge in the form of providing a suitable maintenance schedule during the operational year. We elaborate on possible maintenance configurations and their ramifications in subsection 3.4. The results described in the following paragraphs are based on what proved to be the most suitable choice, namely alternating both long-term and short-term maintenance periods between the unloading units. In this setting, while one of the unloaders is undergoing maintenance work, the other is still operational and hence the period of complete shutdown is minimised to zero, with an influential effect on the unloading functionality.

Table 6 provides a summary of the performance of the modelled system with the same construction as in the validation study of subsection 3.1, after the addition of an identical second unloading unit. The reported findings are based on 50000 simulations. We find a substantial reduction in queueing hours and costs, with the latter dropping to 16% of the reference value. The variability of the results is also considerably reduced, with the upper limit of the confidence interval only marginally exceeding half the original costs and a coefficient of variation of 5.5%. Berth occupancy decreases down to 82% of its original value, with the improved unloading allowing to relieve the pressure between ship arrivals. Finally, the unloaded material only varies in light of the sampling of ship capacity data, as without exception the entire amount of bauxite is processed seamlessly after the upgrade.

Table 6: Result summary for large scale performance indicators (costs, berth occupancy, queueing hours and unloaded material) after the addition of a second unloader to the port terminal.

Indicator	Mean (90% confidence interval)	Coefficient of variation
Costs	0.159753 (0.084837/0.549688)	0.055796
Berth occupancy	0.824783 (0.798483/0.852505)	0.019866
Queueing hours	0.259663 (0.175910/0.706582)	0.024785
Unloaded material	1.002808 (0.998989/1.006581)	0.010547

The addition of a second unloading unit provides substantial benefits in terms of large scale performance gains in the system. As carried out in the previous subsection, we conduct a sensitivity study of the model in order to a. identify which elements would further increase the impact of this investment and b. analyse the effect of potential performance losses.

Fig. 14 describes the effect of the first four control variables, as introduced in the previous subsection. Varying both shore-related delays and pre-unload inspection times produces a limited effect in the presence of the second unloading unit. Costs and queueing hours are unchanged within the test window of 50% to 150% of the historical values, while the transported material is easily accommodated for. This entails a much more reliable functionality of the port terminal, as potential increases/delays in these operations would impose minimal performance modifications. The berth occupancy varies approximately linearly with both these parameters, with any further delays contributing to a growth in berth occupancy from 82% of the historical value to 83.5% in the case of pre-unload inspection times and 84.8% in the case of shore-related delays. The benefit of further reducing these delays would have a proportional effect in terms of yearly berth occupancy, with a decrease of 2 – 3% in each case.

A regularisation of the schedule is found to be more advantageous, with significant reductions in queueing hours and costs, which reach a level of less than 10% of the historical values should the variation in the inter-arrival times decrease by 50%. Note that adding variability in the system at this level has important consequences in terms of performance, with costs more than doubling in the light of larger variations added into the Monte Carlo sampling process. However, even in such a case, the activity proves robust, with important gains still visible as compared to the single unloading unit scenario. A similar dynamics is provided in the case of shed capacity modifications. Berth occupancy is unaffected in case of further upgrades, while the cost gain is comparable to the schedule regularisation case. The effect in case of further capacity reductions is more noticeable, with a 50% capacity reduction leading

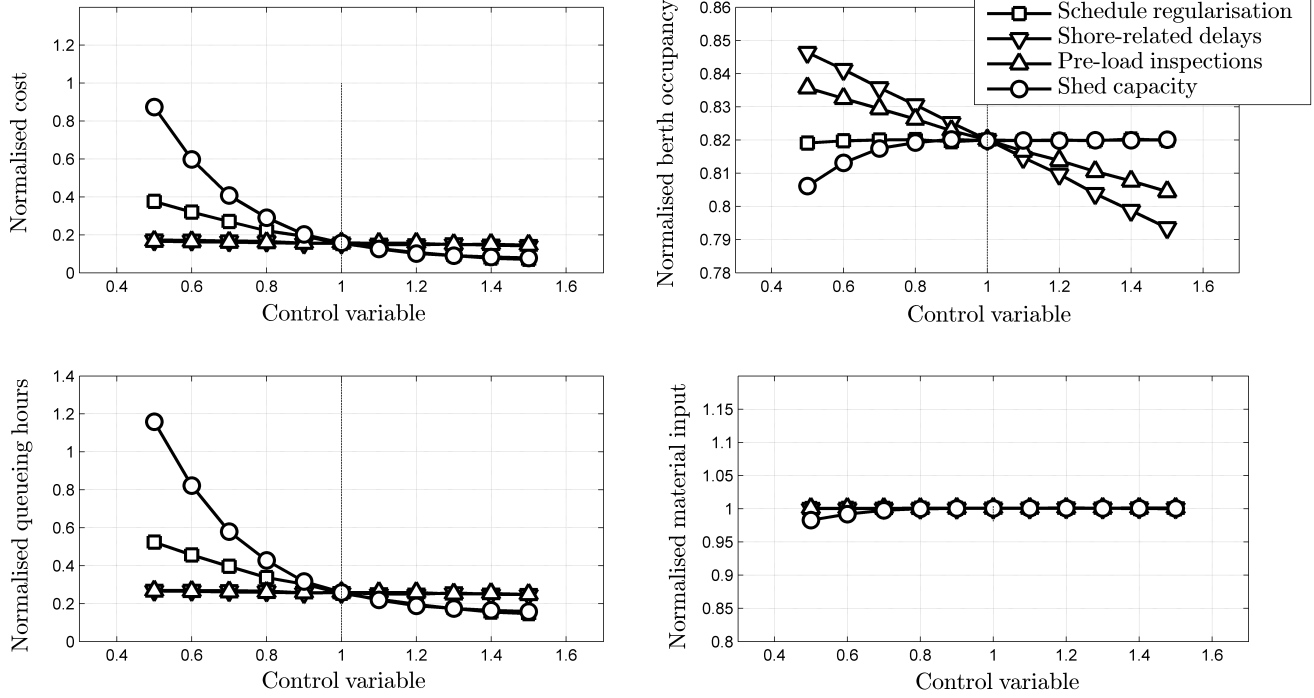

Figure 14: Summary of the impact of parameter variation on large scale performance indicators in the case of two operating unloaders - normalised demurrage costs (top left), normalised berth occupancy (top right), normalised queuing hours (bottom left) and normalised unloaded material (bottom right).

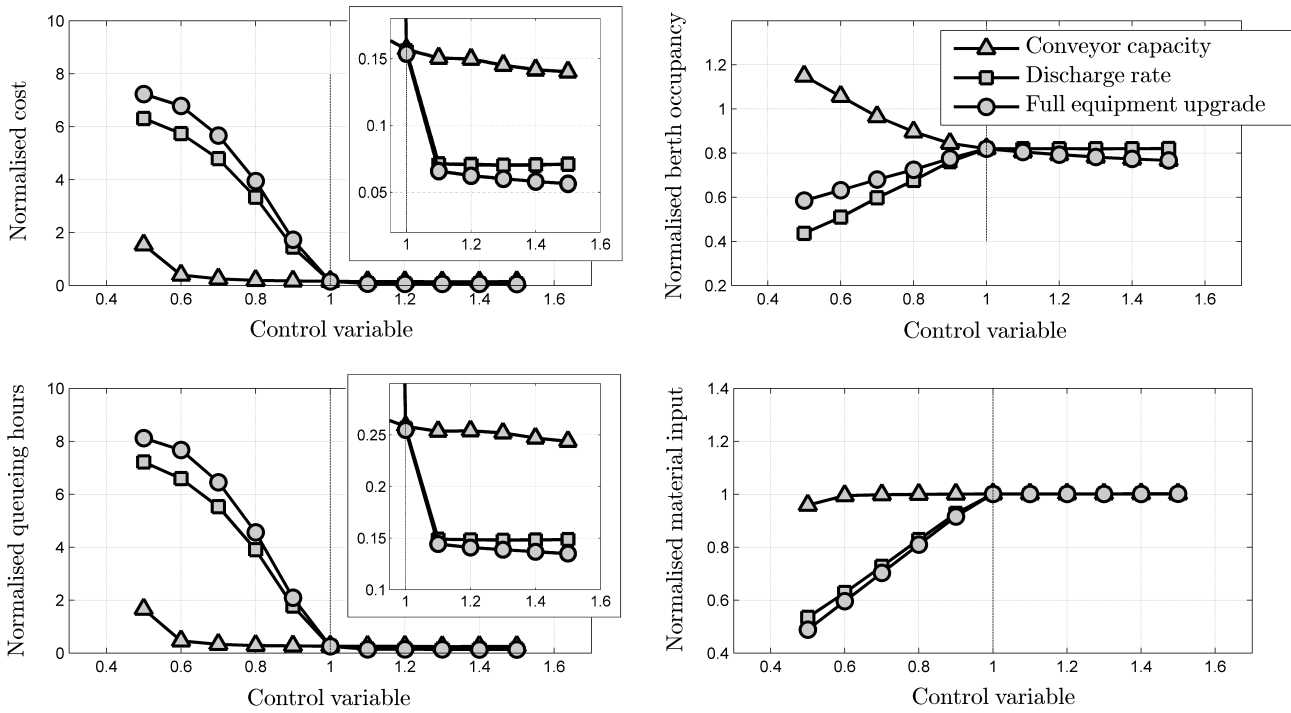

Figure 15: Summary of the impact of parameter variation on large scale performance indicators in the case of two operating unloaders - normalised demurrage costs (top left), normalised berth occupancy (top right), normalised queuing hours (bottom left) and normalised unloaded material (bottom right).

to similar cost levels as prior to the investment in the second unloading unit. In cases of severe losses of capacity, the quantity of unloaded material to be processed also begins to drop, thus indicating a stronger sensitivity of the general port activity to the storage facilities.

Fig. 15 summarises the results of the remaining control variables, from which we discarded further variation in unloading rates as a result of the already performed upgrade in terms of the unloading system. Changes in conveyor capacity, discharge rate and joint logistical changes (conveyor capacity, shed capacity and discharge rates) all impact performance substantially.

We address the effects of modifying the conveyor capacity. Additional upgrades of the current mechanism would help reduce costs by a further 2 – 3%, however the limited pressure in terms of total material to be unloaded during the operational year does not warrant further investment unless heavy increases in material input are expected. Comparing to the single unloader case of Fig. 13, we find that decreases in transport system performance are handled much more robustly by the upgraded model, with costs remaining approximately unchanged except for cases of loss of capacity of more than 40 – 50%. Even in such a scenario, while queueing hours and costs double as compared to the historical values (much stronger impact than all previously discussed control variables), the performance is a major improvement to the single unloader case, which was subject to stronger variability and a fourfold increase in terms of costs and queueing hours.

The discharge rate from the storage facilities is revealed to exert the most significant changes on the modelled system. Even a small increase of 10% would further decrease costs by a factor of two. Furthermore, additional improvements would not further benefit performance in the context of currently processed fleets, making this upgrade particularly attractive. On the other hand, any losses or degradations of the current discharge process would severely affect the activity at the berth, with a very similar dynamics to the single unloader case discussed in Fig. 13. The added functionality does not address the queue formation at Scatterry Island due to long waiting times for the storage facilities to be emptied. While there are minor gains, a cost increase of more than a factor of six is by a large margin the most prominent loss of performance within this study.

Modelling all equipment as a joint variable magnifies previous findings, with modifications in conveyor capacity and discharge rates having a cumulative effect and reducing queueing hours below 14% of the original value, as well as costs down to 5.5% as compared to the historical data. The fundamental change has been revealed to be caused by an upgrade of the material discharge from the sheds, with the conveyor and shed capacities contributing to further cost reductions by 1 – 2%. On the other hand, joint degradation of equipment would have important consequences, with even a 10% decrease causing the inability to process the required amount of material, as well as doubling costs and queueing hours.

We find that the additional unloading unit produced substantial performance gains and an overall significant reduction in sensitivity to unforeseen circumstances. Our results indicate that the storage facilities, in both capacity but in particular in terms of material discharge capabilities to further steps in the refinement process, represent the most relevant equipment upgrade complementing the second unloader. On a larger scale, the developed methodology has shown the required flexibility and level of insight to become a valuable tool in addressing current and future challenges and economic demands within the scope of the modelled system.

3.4. Maintenance configuration

An additional novel aspect of the present investigation, which directly affects the performance of the newly introduced unloading unit, is the imposed maintenance configuration. Maintenance has been described in terms of short- and long-term downtimes during which the respective unloading unit cannot process any material from the bulk carriers. Each of these can occur either simultaneously, affecting both unloaders for a more limited period of time, or in alternative order, in which case the unloading facility reverts to the functionality of a single unloader system. While the causes of short-term disruptions may be beyond the control of the company, the sensitivity of the performance on long-term maintenance is of particular interest. The maintenance policies in the case of a single unloader offer little flexibility, however adding a new unloading unit provides us with the opportunity to model the maintenance configuration in a sensible and efficient manner that would ultimately enhance the performance of the port terminal. To this end, we analyse possible maintenance configurations under the assumption that the total amount of long-term maintenance hours is doubled (accounting for the presence of the second unloader), while the total amount of short-term maintenance hours remains unaffected, as these may not be unloader-related. We underline that, apart from the addition of the second unloader, no other infrastructure modifications are assumed at this stage. This entails that the conveyor capacity, storage capacity and discharge rate remain at the same levels as in the historical data. A series of tests is then designed in the context of processing the fleet of bulk carriers in the historical dataset as follows:

- Configuration A: short- and long-term maintenance can only affect one unloader at once, with long-term maintenance scheduled to alternate between the two and short-term maintenance only being imposed on one unloader at a time;
- Configuration B: long-term maintenance performed alternatively, however short-term maintenance impacts the performance of both unloaders at the same time, thus accounting for larger scale events that affect the overall unloading process;
- Configuration C: long-term maintenance performed simultaneously on both unloaders, while short-term maintenance can only affect one unloader at a time;
- Configuration D: both short- and long-term maintenance performed simultaneously on the unloaders, preventing any unloading activity at the port terminal during these downtimes.

In realistic circumstances, a combination of proposed configurations A and B would be the most likely activity scenario. While long-term maintenance could be scheduled at the start of the activity year in the desired manner, shore-related delays are elements of uncertainty which may or may not affect both unloaders. However studying each configuration in detail provides valuable information on the individual contribution of each factor in terms of the long-term impact on performance. Table 7 summarises the results of this study, indicating the means and limits of the 90% confidence interval in the case of each maintenance configuration.

The results based on configuration A have already been discussed as part of subsection 3.3, in which we have opted for the most efficient configuration to underlie the extensive series of tests examined in the respective study. This is the only configuration that prevents complete downtimes, as any maintenance period is compensated for by

Table 7: Sensitivity of large scale performance indicators to maintenance configuration. Configurations A-D vary the imposition of long-term and/or short-term maintenance on either one or both unloaders simultaneously (see text for details).

Indicator	Configuration A	Configuration B	Configuration C	Configuration D
Costs (90% c.i.)	0.159753 (0.084837/0.549688)	0.168065 (0.090796/0.594911)	0.300477 (0.198420/0.700783)	0.295517 (0.193477/0.696436)
Berth occupancy (90% c.i.)	0.824783 (0.798483/0.852505)	0.792915 (0.766615/0.820400)	0.776685 (0.751095/0.803933)	0.743039 (0.718042/0.769695)
Queueing hours (90% c.i.)	0.259663 (0.175910/0.706582)	0.294397 (0.207703/0.773249)	0.438095 (0.327591/0.886134)	0.462605 (0.351680/0.919467)
Unloaded material (90% c.i.)	1.002808 (0.998989/1.006581)	1.001520 (0.990476/1.006351)	1.000829 (0.989786/1.006121)	1.001520 (0.990246/1.006167)

the activity of one of the two unloaders. We find the total queueing hours to be reduced down to approximately 26% of the historical value, leading to a strong reduction in costs of down to 16%. Furthermore, due to the more rapid servicing of bulk carriers, berth occupancy decreases down to 82.5% of the historical value. All material to be unloaded is processed during the operational year, with the negligible variations explained in the form of the variable ship capacity for each realisation. This feature is representative of all maintenance configurations, as the performance gain after introducing the second unloader allows the processing of the historical fleet of ships in a very efficient manner. Switching to configuration B only produces minor changes to the previous results, suggesting that the short-term maintenance plays a secondary role on the activity as a whole. In this context, bulk carriers having to wait before berthing due to the simultaneous short-term maintenance periods amount to a slightly decreased berth occupancy of 79% of the historical value. This dynamics also translates to an increase in queueing hours and hence costs, however only by a negligible amount of less than 1%.

By contrast, the quantitative analysis of the activity with maintenance configurations C and D reveals that long-term maintenance scheduling can have a strong effect on the performance descriptors. Most notably, queueing hours and costs increase by a factor of two as compared to configurations A and B, now up to approximately 30% of the value in the historical dataset. Berth occupancy is reduced even further down to 74% as a result of the downtimes. We therefore assert that a suitable maintenance schedule, particularly for long-term downtimes, presents considerable benefits and should be carefully considered within the context of strategically expanding and/or improving of the port activity.

3.5. Managing unexpected extreme events

The versatility of the proposed simulation model allows us to address an important issue concerning the management of extreme uncertainty. In order to ensure a realistic behaviour, the system must suitably incorporate unexpected incidents and the occurrence of irregularities in the everyday activity of the port. We recall that up to this point typical delays have been successfully accounted for (see subsection 3.1) using underlying empirical (discrete) distributions for shore-, ship- and weather-related events. These distributions originate from the historical data from the latest available operational year and represent real life events that took place in the system, from staff reassignment to equipment technical issues and material quality concerns introduced by wet or windy conditions.

In addition to the previously mentioned features, due to its flexibility and robustness, the model is well adapted

to inform on the effects additional incidents, not captured by the historical data. To illustrate this, we focus primarily on shore-related events, which are most relevant from the perspective of prevention and management. Three different mechanisms are proposed in order to evaluate the sensitivity of the port activity to unexpected events:

1. Increasing the current average shore-related delays (while sampling from the original empirical distributions and adding a further proportionally defined amount of delays) to up to 200% of their historical value. The mean costs (as well as the minimum and maximum of the 90% confidence interval in each case) are illustrated in increments of 10% in Fig. 16.
2. Doubling the total number of shore-related delays by adding a single large scale event (such as a complete shutdown spanning several days caused by a major logistical issue) for each ship type. Its occurrence has a well-defined likelihood introduced by the sampling procedure from new empirical distributions of the shore-related delays incorporating this feature (implemented such that the expected value of the total delays is twice the corresponding value of the original distributions).
3. Imposing an increased number of short-term maintenance procedures, matching the amount of delays added in points 1 and 2 above. As opposed to the previous two methods, this scenario does not rely on sampling, with interruptions in the operations being imposed at regular intervals irrespective of the ship type or other ongoing port activities.

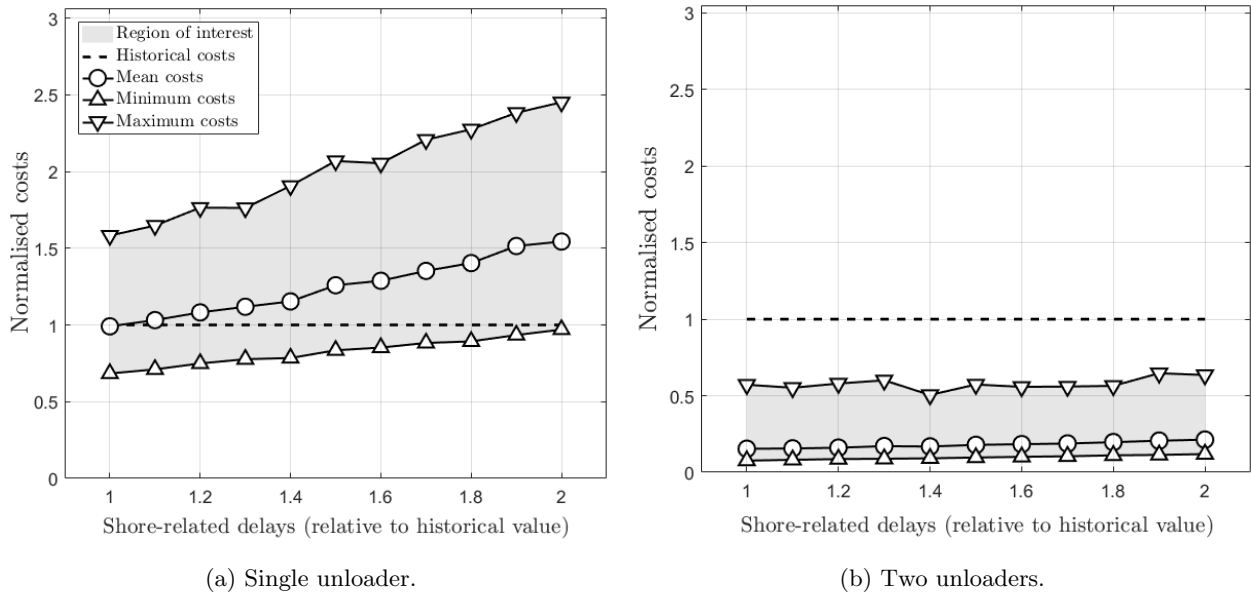

Figure 16: The effect of increasing average shore-related delays from 100% to 200% of their historical value, in increments of 10%, on the mean normalised costs (circles). The lower/upper bounds of the 90% confidence interval are also illustrated using upward/downward facing triangles. Both (a) a single unloader and (b) two unloader configurations are investigated.

To aid comparison, all three scenarios have been constructed to introduce, on average, the same number of additional hours of delays (spanning several days in total) into the system and have been addressed using both a single and two unloading units. The effect on the main performance descriptors (costs, berth occupancy and material unloaded) is summarised in Table 8 as a result of running 10000 simulations in each individual case. When

two unloaders are presented, the most suitable maintenance strategy (as outlined in subsection 3.4) is considered. The exact manner in which the system copes with all types of irregularities, be they single extreme events or delays distributed in different ways (regular or with a variation induced by the sampling procedure) throughout the operational year, are therefore quantified.

Table 8: Sensitivity of large scale performance indicators to the occurrence of irregularities of three different types in the system (increased average shore-related delays, the occurrence of a single large scale incident and an increased number of short-term maintenance procedures), using either one or two unloaders. The variation in costs in the first case is also presented in Fig. 16.

	One unloader			Two unloaders		
Performance indicator	Average delay increase	Single extreme event	Extended maintenance	Average delay increase	Single extreme event	Extended maintenance
Costs	1.531232	1.955485	1.530311	0.175467	0.406239	0.173277
Berth occupancy	1.036253	1.022391	0.985072	0.839262	0.843738	0.824191
Unloaded material	0.977911	0.965025	0.978831	1.003761	1.002526	1.003128

We find that increasing the average level of shore-related delays and adding to the number of short-term maintenance procedures have a similar impact on all performance indicators. This is not unexpected, given the total number of hours the activity is affected is the same and the fact that both mechanisms distribute the delays throughout the year in relatively small periods. We stress that there are minor differences in the distribution of the added irregularities, with the first mechanism following a pre-existing distribution, while the maintenance mechanism allocates the downtimes in equal amounts at regular intervals throughout the operational year. Despite this property, the separation of these delays in relatively small amounts is absorbed similarly within the modelled queue dynamics, with only one or two bulk carriers affected by each individual incident. The inter-arrival time of the ships acts as a buffer in these scenarios. By contrast, the occurrence of a single extreme event results in a different behaviour, with the bulk carrier affected producing substantially more demurrage costs and the following ships in the queue experiencing further (decreasing) delays as part of a strong chain reaction that requires several bulk carriers to accommodate before normal service is resumed. In this last case, the costs while operating under a single unloader configuration almost double when compared to the historical value, as opposed to the distributed uncertainty mechanisms, which induce a cost increase of approximately 53%. In all cases the amount of unloaded material decreases by 2 – 3%. The main outcome of this investigation is however the robust performance of the system when the second unloader is considered. If the added uncertainties are distributed in time (under mechanisms 1 and 3) the normalised costs increase by only 1.5%, from approximately 16% of the historical value (see Table 6) to 17.5% of the historical value, which is a significant improvement to the single unloader configuration. Even in the case of an extreme incident, the added unloading functionality ensures that the impact of the event is not propagated strongly further in the queue, as the delayed bulk carriers are processed much more efficiently. This results in a normalised cost of 40.6% of the historical value, a fivefold decrease as compared to the single unloader case. None of the three new uncertainty mechanisms affect the capacity of the system to process the full target material amount when the second unloader is present.

As a result of the analysis on the impact of a range of irregularities in the modelled port operations, our findings

strongly support the addition of the second unloading unit in enhancing the capabilities of the system in managing extreme uncertainty in its activity.

4. Discussion

In the present section we exploit the functionality of the system to provide useful statistics beyond the level of the large scale performance indicators, a resource which is particularly useful when analysing potential equipment upgrades and future activity targets. With one unloader we find that a relatively small amount of potential activity hours (in terms of unloading) are lost due to sheds being full by either capacity or discharge rate restrictions. We refer to the previously presented Fig. 8 for an example realisation of the discrete event simulation model in which the storage limit is rarely tested within the respective operational year. This is consistent with the findings of Fig. 12-13, which indicate no further performance gains from increasing shed capacity and minor cost reductions of 7 – 8% for the discharge rates. With two unloaders, the amount of operational hours lost due to storage-related restrictions increases almost fivefold, indicating yet again that the sheds are one of the most important bottlenecks in the system after addressing the unloading capabilities. The likelihood of the sheds being full (especially when considering increasing bulk carrier arrival rates) in such cases becomes significant, converting the queueing model into a tandem queueing system, in which the shed discharge activity becomes the second processing stage. Quantifying the blocking effect of the unloading operations (due to the intermediate buffer being full) in such circumstances by discrete-event simulation then becomes beneficial in view of further operation extensions in the future. Additionally, in a typical operational year during which the historical fleet is processed, restrictions on the conveyor system when operating a single unloader have little effect on the unloading activity. However we find a potentially important performance gain when querying for the hours lost due to conveyor capacity limitations in a fully upgraded equipment setting. This change is more subtle in nature, as observing its impact directly is hindered by restrictions in storage or in general other factors.

The periods in time when the berth is free during an operational year also raise a point of interest. The berth is unoccupied in the interval of time between the departure of one ship and the arrival of the next bulk carrier, which may vary from hours (should other vessels be queued at Scatterry Island) to days in the event of reduced activity based on the shipping schedule. There is particular interest in assessing the detailed structure of the berth occupancy, since only longer periods of inactivity at berth (more than a day) allow for potential servicing or in general any form of intervention. After the addition of the second unloader, we find that the cumulated time within an operational year in which the berth is free less than 24 hours decreases by 45%. This is in favour of much longer periods when the berth is free for an extended period of time (more than 24 hours), which on average increase by a factor of 2.55. Even without further upgrades, the gain at the level of possibility in terms of servicing is significant.

Finally, up to this point we have relied on the design of a fleet of bulk carriers that maintain the same characteristics and total capacity (total amount of bauxite) as in the historical dataset. For both validation and test scenario exploration, this has been the natural choice in order to assess the impact of the various components of the model. There are however potential benefits, as we have noted in the case of the conveyor capacity, that are only highlighted in the case of an increased activity level. An important question we can answer with the designed tool is how much more material could be processed during an operational year at the same cost level as in the historical

dataset, however in the context of a fully upgraded facility. Keeping the proportion of bauxite in the fleet fixed and with an additional unloader, all auxiliary equipment upgraded (conveyor capacity, shed capacity and discharge rate) and a favourable maintenance setting, we find a potential to process an additional 51.03% bauxite during an operational year. This would be a substantial augmentation of the current activity level of the company. The value also serves as an indication for the maximum performance gain under the described facility upgrade configuration. Further parameter space explorations beyond the levels of the discussed control variables and their maximum upgraded functional rates of 150% of the historical value are possible should additional strategic directions be sought in the future.

5. Conclusions

We have proposed a simulation model for the systematic study of extended port terminal operations at the RUSAL Aughinish refinery in Ireland. The methodology includes non-standard features, such as a moderate distance between the queue and the server, the presence of specialised conveyor and storage units for the raw material (as opposed to the more common container handling) and additional unloading functionality, which induces the selection between single-server and two-server queueing systems. It acts as a predictive tool, capable of isolating and exploring the contributions of both individual and joint components within the port network. Emphasis has been placed on practicality and flexibility, with the model constructed to assist in long-term investment planning and decision making strategies.

The first step in our analysis was a comprehensive validation exercise, comparing the simulated activity with historical data. The agreement found was further consolidated by detailed information on the variability present in the system. The study combines new elements of simulation modelling for port terminal operations with features that account for the uncertainty in the everyday activity of the company. These range from the level of the bulk carriers themselves which vary in terms of size and inter-arrival times, to all forms of delays (ship-, shore- and weather-related) that may affect the system. Thus the simulated dynamics not only captures mean features of the system, but also enables a view of the variation window of performance indicators such as costs, berth occupancy and total material processed during an activity year.

Next we tested the impact of key elements in the model in order to determine the most fruitful direction of improvement in light of reliability, performance and capability expansion. Following these studies, an extension to the unloading facility emerged as having the strongest influence on the system. Managing the discharge rate from the storage facilities is also required in order to avoid delays caused by accumulation of bauxite, with even a small functional increase proving sufficient to minimise costs and reduce sensitivity. A regularisation of the schedule and a reduction of shore-related delays were also found to have beneficial, however limited effects when compared to the previous factors. These findings motivated us to introduce a second unloading unit, thus addressing the principal factor revealed by the extensive parameter exploration. Coupled with an appropriate maintenance configuration, as examined in subsection 3.4 (see Table 7 in particular), this investment leads to a reduction in costs of approximately 85%. In subsection 3.5 we have underlined how the added functionality also supports the management of extreme uncertainty in the activity of the port. We then conducted an analysis indicating that when complemented by expansions of the conveyor capacity and increased discharge rates, the costs would drop to less than 10% of the

historical value. Berth occupancy is also positively affected, with the additional unloader producing significantly longer periods in which the berth is free for servicing and intervention.

All designed scenarios can be addressed in a realistic context, as elements under the full control of the company have been selected in favour of factors whose uncertainty levels are beyond reach (such as weather-related delays). Finally, the model is capable of exploring the effect of future modifications in the processing activity. To this end, it has been found that an increase of material input of more than 50% is possible with the improved facilities without exceeding the current costs. Adopting a long-term investment strategy then becomes naturally linked to the economic decision of systematically examining the balance between the benefits of the suggested infrastructure upgrades and the costs associated with their acquisition and deployment. Determining the most appropriate policy under such circumstances has been the subject of prominent investigations in the literature, as in the case of Bendall and Stent (2005) and Demirci (2003).

While many of the features of the model have been developed in a specialised setting addressing the activity of RUSAL Aughinish and its possible extensions, we believe the suggested methodology introduces many useful general features in the area of extended port terminal operations. In particular, we emphasise:

- i. the inclusion of logistical elements outside the port terminal, such as the conveyor system and storage facilities;
- ii. the systematic testing of individual performance upgrades in the form of control variables, allowing the identification of potential investment directions;
- iii. the large scale modification of a second unloading unit, bringing fundamental changes to the algorithms and port terminal functionality;
- iv. the detailed discussion on maintenance configurations and their effect on the activity;
- v. the investigation on how the modelled system manages different types of uncertainties in its operations.

We consider that the current work is a valuable resource in furthering the understanding of port activity in all its complexity. The comprehensive modelling techniques have been complemented by an in-depth analysis of the system properties beyond the level of inspection of a limited set of large scale variables. While performance indicators are carefully monitored in all test scenarios, we also report on individual operational aspects of the model, from queueing patterns in bulk carrier movement to the amount of material in the storage facilities and the exerted pressure on the transport mechanism. The discussion section 4 provides additional practical information in terms of the benefits of introducing an additional unloader and the impact of this change on the connected system components. The question of how port activity levels could be increased given suggested strategic upgrades within certain cost-oriented performance targets is also addressed. We therefore conclude that the proposed model of the port environment integrating berth, transport, storage and discharge activities offers insight into the relative contribution and sensitivity of the different logistical elements involved in the management of port operations. Furthermore, the simulation platform and the underlying algorithm are adaptable to a multitude of conditions, making this progress transferable to the wider context of port activity optimisation, planning and investment.

Acknowledgements

All authors gratefully acknowledge the generous support of RUSAL Aughinish, in particular the contributions of Louise Clune and Bernadette Sinnott. All authors also wish to thank Joanna Jordan and Sinéad Burke of MACSI. M.D. acknowledges the support of the Science Foundation Ireland award 09/SRC/E1780 and the ESRI's Energy Policy Research Center.

References

- Angeloudis, P., Bell, M.G.H., 2011. A review of container terminal simulation models. *Maritime Policy and Management* 38, 523–540.
- van Asperen, E., Borgman, B., Dekker, R., 2013. Evaluating impact of truck announcements on container stacking efficiency. *Flexible Services and Manufacturing Journal* 25, 543–556.
- Bendall, H.B., Stent, A.F., 2005. Ship investment under uncertainty: Valuing a real option on the maximum of several strategies. *Maritime Economics & Logistics* 7, 19–35.
- Bielli, M., Boulmakoul, A., Rida, M., 2006. Object oriented model for container terminal distributed simulation. *European Journal of Operational Research* 175, 1731 – 1751.
- Borgman, B., van Asperen, E., Dekker, R., 2010. Online rules for container stacking. *OR spectrum* 32, 687–716.
- Bugaric, U.S., Petrovic, D.B., 2007. Increasing the capacity of terminal for bulk cargo unloading. *Simulation Modelling Practice and Theory* 15, 1366–1381.
- Bugaric, U.S., Petrovic, D.B., Jeli, Z.V., Petrovic, D.V., 2012. Optimal utilization of the terminal for bulk cargo unloading. *Simulation* 88, 1508–1521.
- Bugaric, U.S., Petrovic, D.B., Petrovic, Z., Pajcin, M., Markovic-Petrovic, G., 2011. Determining the capacity of unloading bulk cargo terminal using queuing theory. *Strojniški vestnik-Journal of Mechanical Engineering* 57, 405–416.
- Caballini, C., Pasquale, C., Sacone, S., Siri, S., 2014. An event-triggered receding-horizon scheme for planning rail operations in maritime terminals. *IEEE Transactions on Intelligent Transportation Systems* 15, 365–375.
- Carlo, H.J., Vis, I.F., Roodbergen, K.J., 2014. Transport operations in container terminals: Literature overview, trends, research directions and classification scheme. *European Journal of Operational Research* 236, 1–13.
- Carteni, A., De Luca, S., 2010. Analysis and modeling of container terminal handling activities. *European Transport* , 52–71.
- Carteni, A., De Luca, S., 2012. Tactical and strategic planning for a container terminal: Modelling issues within a discrete event simulation approach. *Simulation Modelling Practice and Theory* 21, 123–145.

- Chang, D., Jiang, Z., Yan, W., He, J., 2010. Integrating berth allocation and quay crane assignments. *Transportation Research Part E: Logistics and Transportation Review* 46, 975–990.
- Cimpeanu, R., Devine, M.T., Tocher, D., Clune, L., 2015. Development and analysis of a port terminal loader model at RUSAL Aughinish. *Simulation Modelling Practice and Theory* 51, 14–30.
- Cortes, P., Munuzuri, J., Ibanez, J.N., Guadix, J., 2007. Simulation of freight traffic in the Seville inland port. *Simulation Modelling Practice and Theory* 15, 256 – 271.
- Demirci, E., 2003. Simulation Modelling and Analysis of a Port Investment. *Simulation* 79, 94 – 105.
- Douma, A., van Hillegersberg, J., Schuur, P., 2012. Design and evaluation of a simulation game to introduce a Multi-Agent system for barge handling in a seaport. *Decision support systems* 53, 465–472.
- Dragović, B., Tzannatos, E., Park, N.K., 2016. Simulation modelling in ports and container terminals: literature overview and analysis by research field, application area and tool. *Flexible Services and Manufacturing Journal* , 1–31.
- Du, Y., Chen, Q., Quan, X., Long, L., Fung, R.Y., 2011. Berth allocation considering fuel consumption and vessel emissions. *Transportation Research Part E: Logistics and Transportation Review* 47, 1021–1037.
- Fanti, M., Iacobellis, G., Ukovich, W., Boschian, V., Georgoulas, G., Stylios, C., 2015. A simulation based Decision Support System for logistics management. *Journal of Computational Science* 10, 86–96.
- Guldogan, E., 2010. Simulation-based analysis for hierarchical storage assignment policies in a container terminal. *Simulation* 87, 523–537.
- Hendriks, M., Laumanns, M., Lefebvre, E., Udding, J.T., 2010. Robust cyclic berth planning of container vessels. *OR spectrum* 32, 501–517.
- Iannone, R., Miranda, S., Prisco, L., Riemma, S., Sarno, D., 2016. Proposal for a flexible discrete event simulation model for assessing the daily operation decisions in a ro-ro terminal. *Simulation Modelling Practice and Theory* 61, 28–46.
- Legato, P., Mazza, R., Trunfio, R., 2013. Medcenter Container Terminal SpA uses simulation in housekeeping operations. *Interfaces* 43, 313–324.
- Legato, P., Mazza, R.M., 2001. Berth planning and resources optimisation at a container terminal via discrete event simulation. *European Journal of Operational Research* 133, 537–547.
- Legato, P., Mazza, R.M., Gulli, D., 2014. Integrating tactical and operational berth allocation decisions via Simulation-Optimization. *Computers & Industrial Engineering* 78, 84–94.
- Lin, J., Gao, B., Zhang, C., 2014. Simulation-based investment planning for Humen Port. *Simulation Modelling Practice and Theory* 40, 161 – 175.

- Longo, F., 2010. Design and integration of the containers inspection activities in the container terminal operations. *International Journal of Production Economics* 125, 272–283.
- Longo, F., Huerta, A., Nicoletti, L., 2013. Performance analysis of a southern Mediterranean seaport via discrete-event simulation. *Strojniški vestnik-Journal of Mechanical Engineering* 59, 517–525.
- Mat Tahar, R., Hussain, K., 2000. Simulation and analysis for the kelang container terminal operations. *Logistics Information Management* 13, 14–20.
- Petering, M.E., 2009. Effect of block width and storage yard layout on marine container terminal performance. *Transportation Research Part E: Logistics and Transportation Review* 45, 591 – 610.
- Petering, M.E., 2011. Decision support for yard capacity, fleet composition, truck substitutability, and scalability issues at seaport container terminals. *Transportation Research Part E: Logistics and Transportation Review* 47, 85–103.
- Qu, X., Meng, Q., 2012. Development and applications of a simulation model for vessels in the Singapore Straits. *Expert Systems with Applications* 39, 8430 – 8438.
- Rida, M., 2014. Modeling and optimization of decision-making process during loading and unloading operations at container port. *Arabian Journal for Science and Engineering* 39, 8395–8408.
- Saurí, S., Morales-Fusco, P., Martín, E., Benítez, P., 2014. Comparing manned and automated horizontal handling equipment at container terminals: productivity and economic analysis. *Transportation Research Record: Journal of the Transportation Research Board* , 40–48.
- Shabayek, A.A., Yeung, W.W., 2002. A simulation model for the Kwai Chung container terminals in Hong Kong. *European Journal of Operational Research* 140, 1 – 11.
- Song, L., Cherrett, T., Guan, W., 2012. Study on berth planning problem in a container seaport: Using an integrated programming approach. *Computers & Industrial Engineering* 62, 119–128.
- Sun, Z., Lee, L.H., Chew, E.P., Tan, K.C., 2012. MicroPort: A general simulation platform for seaport container terminals. *Advanced Engineering Informatics* 26, 80 – 89.
- Sun, Z., Tan, K.C., Lee, L.H., Chew, E.P., 2013. Design and evaluation of mega container terminal configurations: An integrated simulation framework. *Simulation* 89, 684–692.
- Tang, G., Wang, W., Song, X., Guo, Z., Yu, X., Qiao, F., 2016. Effect of entrance channel dimensions on berth occupancy of container terminals. *Ocean Engineering* 117, 174–187.
- Tierney, K., Voß, S., Stahlbock, R., 2014. A mathematical model of inter-terminal transportation. *European Journal of Operational Research* 235, 448–460.
- Verdonck, L., Caris, A., Ramaekers, K., Janssens, G.K., 2014. Analysis of the operations of an intermodal barge terminal. *International Journal of Simulation and Process Modelling* 9, 3–15.

- van Vianen, T., Ottjes, J., Lodewijks, G., 2014. Simulation-based determination of the required stockyard size for dry bulk terminals. *Simulation Modelling Practice and Theory* 42, 119–128.
- Wang, S., Liu, Z., Qu, X., 2015. Collaborative mechanisms for berth allocation. *Advanced Engineering Informatics* 29, 332–338.
- Yun, W.Y., Choi, Y.S., 1999. A simulation model for container-terminal operation analysis using an object-oriented approach. *International Journal of Production Economics* 59, 221 – 230.
- Zhen, L., Chang, D.F., 2012. A bi-objective model for robust berth allocation scheduling. *Computers & Industrial Engineering* 63, 262–273.
- Zhen, L., Lee, L.H., Chew, E.P., 2011. A decision model for berth allocation under uncertainty. *European Journal of Operational Research* 212, 54 – 68.