



Title	Risk averse optimal operation of a virtual power plant using two stage stochastic programming
Authors(s)	Tajeddini, Mohammad Amin, Rahimi-Kian, Ashkan, Soroudi, Alireza
Publication date	2014-08-14
Publication information	Tajeddini, Mohammad Amin, Ashkan Rahimi-Kian, and Alireza Soroudi. "Risk Averse Optimal Operation of a Virtual Power Plant Using Two Stage Stochastic Programming." Elsevier, August 14, 2014. https://doi.org/10.1016/j.energy.2014.06.110 .
Publisher	Elsevier
Item record/more information	http://hdl.handle.net/10197/6116
Publisher's statement	This is the author's version of a work that was accepted for publication in Energy. Changes resulting from the publishing process, such as peer review, editing, corrections, structural formatting, and other quality control mechanisms may not be reflected in this document. Changes may have been made to this work since it was submitted for publication. A definitive version was subsequently published in Energy (VOL 73, ISSUE 2014, (2014)) DOI: 10.1016/j.energy.2014.06.110
Publisher's version (DOI)	10.1016/j.energy.2014.06.110

Downloaded 2026-05-02 00:26:00

The UCD community has made this article openly available. Please share how this access benefits you. Your story matters! (@ucd_oa)



© Some rights reserved. For more information

Risk Averse Optimal Operation of a Virtual Power Plant using two Stage Stochastic Programming

Mohammad Amin Tajeddini^{*,a}, Ashkan Rahimi-Kian^a, Alireza Soroudi^b

^aSmart Network Laboratory, School of Electrical and Computer Engineering, University of Tehran, Tehran, Iran.

^bRenewable Energies and Environmental Department, Faculty of new Science and Technologies, University of Tehran, Tehran, Iran

Abstract

Virtual Power Plant (VPP) is defined as a cluster of energy conversion/storage units which are centrally operated in order to improve the technical and economic performance. This paper addresses the optimal operation of a VPP considering the risk factors affecting its daily operation profits. The optimal operation is modelled in both day ahead and balancing markets as a two-stage stochastic mixed integer linear programming in order to maximize a generation companys (GenCo) expected profit. Furthermore, the Conditional Value at Risk (CVaR) is used as a risk measure technique in order to control the risk of low profit scenarios. The uncertain parameters, including the PV power output, wind power output and day-ahead market prices are modelled through scenarios. The proposed model is successfully applied to a real case study to show its applicability and the results are presented and thoroughly discussed.

Key words: VPP, Two-stage stochastic programming, Risk, CVaR, Scenario based modelling, Uncertainty .

1. Introduction

Due to the increase of concerns related to environmental issues, decrease in the level of fossil fuels resources and advancement of technology, higher share of distributed energy resources is being observed worldwide. So, the Distributed Generation (DG) and Renewable Energy Sources (RES) are going to replace traditional fossil fuelled power plants to promote energy efficiency

*Corresponding author

Email addresses: a.tajeddini@ut.ac.ir, Department of Electrical and Computer Engineering Tehran University Amir-abad Ave., P. O. Box 11365-9363. Tehran, Iran. Tel : (Office) +98(21) 61114222 Fax : +98(21) 61114223 (Mohammad Amin Tajeddini), arkian@ut.ac.ir (Ashkan Rahimi-Kian), alirezatoroudi@gmail.com (Alireza Soroudi)

and generate green energy. The Virtual Power Plant (VPP) enables the associated RES and DG to participate in electricity markets as a single power plan [1, 2].

Shimon Awerbuch in 1997 introduced the origin of the terminology VPP in his book entitled the Virtual Utility for the first time [3]. The idea of VPP is to refer the integration of small scale generation and storage technologies (that are not located at the same bus) to operate and behave as a single unit. The main goal of this entity is to maximize the benefits of the participants to take advantage of a larger capacity in the energy markets [4, 5]. The commercial VPP (CVPP) and technical VPP (TVPP) are two popular types of VPP operation. The focus of CVPP is a profit maker agent which optimizes its operating schedule based on the wholesale markets. The obtained results are given to TVPP. The TVPP implements them considering the local network constraints [6]. In [7, 8], some simple VPP models were considered. From a modelling point of view, a VPP usually includes dispatchable power plants, storage units and non-dispatchable generation units such as wind turbines and photovoltaic. By the end of 2011, the total renewable power capacity has increased up to 1.360 GW [9]. Besides the advantages and benefits of these renewable energy sources, the amounts of power production are intrinsically dependent on the stochastic behaviour of nature such as clouds and solar irradiation. These uncertainties would impose imbalance costs to the system operators [10, 11]. In order to diminish the effects of these imbalances, different types of renewable and non-renewable generators and storage devices are combined into a single VPP. In [12], the optimization model was formulated as a two-stage stochastic problem in which, the day-ahead energy market prices and wind power generations were considered as uncertain parameters. In that paper, the hydro pumped storage was used to manage the Wind Power Plant (WPP) stochastic generations. In [13], an offering model for the VPP was presented based on a two-stage stochastic programming. In the proposed method, the VPP included a wind farm and a cascade hydro-power system. Moreover, the author assumed trading in the day-ahead energy market with predefined penalty for power mismatch offered by the VPP operator. However, in real applications, the VPP owner can participate in balancing and/or real-time energy markets to cope with the mismatch between day-ahead offering and its real energy production. Also the VPP consists dispatchable power plants in order to diminish the uncertainties. In [14], an offering model for a VPP based on stochastic programming is presented. Despite of the advantage of handling

the uncertainties using stochastic programming, its main drawback is neglecting the probability distribution associated with the random variables. In [15], the optimal offering strategy of the coordinated wind-thermal power plants was proposed and the market risks were modelled and optimized using the CVaR model. In [16, 17], a self-scheduling problem was presented, and the risk was modeled by considering the variance of the market clearing prices. However, it is known that by using CVaR and VaR, the risk management can be done more effectively [18, 19].

In this paper, an efficient stochastic programming with risk management is used for optimal daily operation of a VPP that includes, Conventional Power Plants (CPPs), PV, wind farm and battery bank as the storage unit. The typical schematic of a VPP is shown in Fig.1.

The proposed optimization problem is a mixed integer linear programming (MILP) [20], formulated as a two-stage stochastic programming model. In the first stage, the optimal decision is made for the day-ahead energy market quantity bids for each hour. In the second stage, the VPP operator will decide on the optimal operation of CPPs and battery, once the outputs of non-dispatchable generation units and day-ahead energy market prices are known. In this paper, the CVaR risk management method is used to model and control the risks of low profit scenarios. The proposed formulation investigates both day-ahead and balancing energy markets. The VPP uses trading in both day-ahead and balancing energy markets to reduce its market risks due to uncertain parameters such as wind and PV outputs and the market price by means of the CVaR risk management algorithm [5, 21]. It means that the VPP uses the balancing market to correct its energy deviations with respect to its day-ahead schedule. In the other words, the VPP sells its extra energy in the balancing energy market and purchases its shortage of energy in the balancing energy market. The main novelty of the proposed method (compared to the existing literature) is the inclusion of risk measure and management for protecting the VPP operator from low profit scenarios in day-ahead and balancing energy markets when it operates non-dispatchable energy sources (such as wind and PV generators). In the proposed optimization problem and case studies, the considered uncertain parameters include the PV power output, wind power output and day-ahead energy market prices, which are modelled with different probabilistic scenarios.

The rest of the paper is organized as follows: sections 2 and 3 provide the model description

and formulation, respectively; the simulation results of a real case study are presented in section 4, and the paper is concluded in section 5.

2. Model Description

The studied VPP consists of a WPP, a PV, a micro turbine, a diesel generator and a battery bank. The WPP and PV outputs are stochastic and therefore, are provided by various probabilistic scenarios. In order to preserve the linearity of the model, piecewise linear approximation is used to model the quadratic CPP cost function. Through using the battery bank, the VPP operator could hedge against the volatile balancing market price risks and also reduce the operation risks of the stochastic WPP and PV generators.

In this paper, due to relatively small installed capacities of the VPP components, the VPP operator is considered as a price-taker that cannot affect the hourly market price. The day-ahead and balancing energy markets are considered for the VPP to trade the energy on an hourly basis. In a day-ahead energy market, the daily operation of the power system is determined, where the consumers and suppliers submit their bids/offers into the day-ahead energy market 10-14 hour prior to the day of operation. The balancing energy market provides the opportunity for the producers/ consumers to sell/ purchase electricity near real time. The VPP operator could participate in the balancing market as an alternative to cope with non-dispatchable generators uncertainties (e.g., WPP and PV generators).

Stochastic generation are the means that produce electricity from renewable energy. Their production is uncertain due to the variability of weather conditions such as, sunlight, wind, and etc. Therefore, the sunlight irradiation and wind speed are needed to be estimated precisely for optimal offering in the market. Moreover, there is another uncertain parameter related to the day ahead market prices. To deal with these uncertainties, different scenarios are considered for PV and wind farm outputs and also day ahead market prices.

In the rest of this section, first, the sources of the uncertainties are clearly described and next, an introduction of the some popular risk measure technique is introduced.

2.1. Uncertainties

In general, a VPP contains dispatchable power plants, storage devices, and stochastic (non-dispatchable) generation units.

In this paper, the stochastic scenario based uncertainty modelling is used for dealing with the uncertainties of unknown parameters [22]. Different scenarios for uncertain PV, WPP and day-ahead energy prices are generated based on the Monte Carlo simulations. The probability distribution functions (PDFs) for the wind speed, solar irradiation and day-ahead market prices are assumed to be Weibull, Gamma and Gaussian, respectively [23]. To handle the above mentioned uncertainties, a two-stage mathematical programming with two different kinds of decisions is used [24]. The first stage or “hear and now” decisions are made before the realization of the stochastic process; the second stage or “wait and see” decisions are made after knowing the actual realization of the uncertainties. The here and now decision is the amount of supply offer, which is submitted to the day-ahead energy market for each hour, and the wait and see decision is the operation of dispatch-able power plants and the storage devices.

2.2. Risk Measurement

In order to control the risk of experiencing low profit scenarios, we need to model the associated profit risk and then include it into stochastic programming models. The MVP (mean-variance portfolio), shortfall probability, expected shortage, value at risk (VaR) and conditional value at risk are the most usual risk assessment models in energy market trading [25]. In this paper, the concepts of VaR and CVaR are used for risk modeling and optimization in day-ahead and balancing energy markets. In the following, the VaR and CVaR concepts are briefly explained:

- Value at risk

The VaR is equal to the largest value η such that, with probability of α , the profit will not be less than η . The VaR can be formulated as in (1).

$$VaR(\alpha, x) = \max \{ \eta : P(w | f(x, w) < \eta) \leq 1 - \alpha \}, \quad \forall \alpha \in (0, 1) \quad (1)$$

where $f(x, w)$ is a profit function, w is an uncertain parameter and x is a certain parameter. It is worth mentioning that η is not a given parameter.

- Conditional Value at risk

The CVaR is defined as the expected value of profit function smaller than $(1 - \alpha)$ -quantile of the profit distribution. CVaR can be defined as in equation (2).

$$CVaR(\alpha, x) = \max \left\{ \eta - \frac{1}{1 - \alpha} E_w \{ \max \{ \eta - f(x, w), 0 \} \} \right\} \quad \forall \alpha \in (0, 1) \quad (2)$$

For the same confidence level α used for VaR and CVaR, CVaR provides an estimate of the risk lower than the VaR value. So, CVaR gives a better indication of risk than VaR. Moreover, it is required to assume the Gaussian distribution for uncertain parameters in VaR. The main disadvantage of VaR is that, it gives no information about the profit distribution beyond the value of η . In addition VaR cannot be easily applied to the non-normal distribution. Therefore, in this paper the CVaR is used to model and optimize the energy market risks.

3. Model Formulation

The VPP model consists of WPP, PV power plant, conventional micro-turbine, conventional diesel generator and Li-ion battery bank. The WPP and PV outputs are considered stochastic together with the day-ahead energy market price.

The VPPs objective function is formulated as follows:

$$\begin{aligned} \max \quad & \sum_{t=1}^T \left\{ \sum_{w=1}^{n_w} \pi(w) \cdot \sum_{s=1}^{n_s} \pi(s) \cdot \sum_{p=1}^{n_p} \pi(p) \{ \lambda^p(t) (G_p(t) + 0.7P_{wsp}^{up}(t) - 1.3P_{wsp}^{down}(t)) \right. \\ & \left. - \sum_{j=1}^2 OC_j(t) - y(t)_{j,wsp} \cdot C_{SU,j} - s_{wsp,j}(t) \cdot C_{SD,j} \} \right\} + \beta Risk \end{aligned} \quad (3)$$

The first term of the objective function in (3) refers to the electricity sell/purchase in the day-ahead market ($G_p(t)$) and electricity sell ($P_{wsp}^{up}(t)$)/purchase ($P_{wsp}^{down}(t)$) in balancing market. Following current practice in European markets, it is assumed that, the VPP can only purchase energy in the balancing market at the price higher than day-ahead market ($1.3\lambda^p(t)$). Similarly, VPP can only sell energy in balancing energy market at the price lower than day-ahead energy market ($0.7\lambda^p(t)$). The second term in (3), refers to the operation cost, start-up cost and shut-down cost of the CPPs respectively. The last term is about the risk measure formulation where, β defines the importance of risk minimization in the objective function. The following technical constraints should be considered as the VPPs operating conditions:

$$g_{j, wsp}(t) = \sum_{i=1}^{n_j} g_{j, wspi}(t) \quad (4)$$

$$OC_j(t) = A_j u_{j, wsp}(t) + \sum_{i=1}^{n_j} F_{i,j} g_{j, wspi}(t) \quad (5)$$

$$\underline{g}_j u_{j, wsp}(t) \leq g_{j, wsp}(t) \leq \bar{g}_j u_{j, wsp}(t) \quad (6)$$

$$-ramp_{j, down} \leq g_{j, wsp}(t) - g_{j, wsp}(t-1) \leq ramp_{j, up} \quad (7)$$

$$y_{j, wsp}(t) + s_{j, wsp}(t) \leq 1 \quad (8)$$

$$y_{j, wsp}(t) - s_{j, wsp}(t) = u_{j, wsp}(t) - u_{j, wsp}(t-1) \quad (9)$$

$$y_{j, wsp}(t), s_{j, wsp}(t), u_{j, wsp}(t) \in \{0, 1\} \quad (10)$$

$$\forall t \leq T, w \leq n_w, s \leq n_s, p \leq n_p$$

Constraint (4) states that the CPPs total generation should be equal to the sum of all blocks. Constraint (5) defines the CPPs operation cost. Constraint (6) defines the minimum and maximum outputs of the CPPs; and constraint (7) enforces the ramp-up and ramp-down limits [26, 27]. Constraints (8), (9) and (10) preserve the logic of running, start up and shut down status changes.

$$\sum_{t=1}^q [1 - u_{j, wsp}(t)] = 0 \quad \forall t \leq T, w \leq n_w, s \leq n_s, p \leq n_p \quad (11)$$

$$\sum_{n=t}^{t+up_j-1} u_{j, wsp}(n) \geq up_j y_{j, wsp}(t) \quad (12)$$

$$\forall t = q + 1 \cdots T - up_j + 1, w \leq n_w, s \leq n_s, p \leq n_p$$

$$\sum_{n=t}^T \{u_{j, wsp}(n) - y_{j, wsp}(t)\} \geq 0 \quad (13)$$

$$\forall t = T - up_j + 2 \cdots T, w \leq n_w, s \leq n_s, p \leq n_p$$

Constraints (11), (12) and (13) enforce the minimum up time; q is the number of initial periods during which, the CPPs must be online; q is mathematically expressed as $q = \text{Min}\{T, [up_j - u_{j,0}]u_j(0)\}$. Constraint (11) refers to the initial status of the CPPs. Constraint (12) is used for the subsequent periods to satisfy the minimum up time constraint during consecutive periods of size up_j . Constraint (13) models the final $up_j - 1$ periods in which, if the CPPs have started up, it remains online until the end of time span. [In fact the time horizon is separated in to](#)

three periods. Period one satisfy the minimum up time constraint if the unit has been on at hour 0 for fewer hours than the minimum up time. Period two enforces the minimum up time constraint for all possible sets of consecutive hours of size up_j and the third period enforces the minimum up time constraint for the last $up_j - 1$.

$$\sum_{t=1}^l u_{j, wsp}(t) = 0 \quad \forall t \leq T, w \leq n_w, s \leq n_s, p \leq n_p \quad (14)$$

$$\sum_{n=t}^{t+down_j-1} [1 - u_{j, wsp}(n)] \geq down_j [u_{j, wsp}(t-1) - u_{j, wsp}(t)] \quad (15)$$

$$\forall t = l + 1 \cdots T - down_j + 1, w \leq n_w, s \leq n_s, p \leq n_p$$

$$\sum_{n=t}^T \{1 - u_{j, wsp}(n) - [u_{j, wsp}(t-1) - u_{j, wsp}(t)]\} \geq 0 \quad (16)$$

$$\forall t = T - down_j + 2 \cdots T, w \leq n_w, s \leq n_s, p \leq n_p$$

Similarly, constraints (14), (15) and (16) enforce the minimum down time; where l is the number of initial periods during which, the CPPs must be offline; l is mathematically expressed as $l = \text{Min}\{T, [down_j - s_{j,0}][1 - u_j(0)]\}$.

$$\underline{g}_{batt} \leq g_{batt, wsp}(t) \leq \bar{g}_{batt} \quad (17)$$

$$SOC_{wsp}(t+1) = SOC_{wsp}(t) + \eta_c g_{batt, wsp}(t) z_{batt, wsp}^c - \frac{g_{batt, wsp}(t) z_{batt, wsp}^d}{\eta_d} \quad (18)$$

$$\underline{SOC} \leq SOC(t)_{batt, wsp}(t) \leq \overline{SOC} \quad (19)$$

$$z_{batt, wsp}^c(t) + z_{batt, wsp}^d(t) \leq 1 \quad (20)$$

$$\forall t \leq T, w \leq n_w, s \leq n_s, p \leq n_p$$

Constraint (17) limit the upper and lower levels of the battery's charging and discharging, respectively. Constraint (18) is the available charging level, constraint (19) shows the upper and lower levels of available charging, and constraint (20) is the binary variable declaration.

$$g_w(t) + g_s(t) + z_{batt, wsp}^d g_{batt, wsp}(t) + P_{wsp}^{down}(t) + g_{j, wsp}(t) = G_p(t) + z_{batt, wsp}^c g_{batt, wsp}(t) + P_{wsp}^{up}(t) \quad \forall t \leq T, w \leq n_w, s \leq n_s, p \leq n_p \quad (21)$$

Constraint (21) is the energy balance equation. It states that the sum of the electricity produced by the WPP, PV, battery, CPP and the electricity purchased from the balancing market should

be equal to the sum of the electricity sold/ purchased in day-ahead market, the electricity used for charging the battery and the electricity sold in the balancing market.

$$G_{w_1,s_1,p}(t) = G_{w_1,s_2,p}(t) = G_{w_2,s_1,p}(t) = \dots G_{w_n,s_n,p}(t) \quad \forall t \leq T, p \leq n_p \quad (22)$$

Constraint (22) is non-anticipatively constraint. It guarantees that only one bidding curve can be submitted to day-ahead energy market for each hour, irrespective of the WPP and PV outputs.

$$\begin{aligned} & \eta - \sum_{t=1}^T \lambda^p(t)(G_p(t) + 0.7P_{wsp}^{up}(t) - 1.3P_{wsp}^{down}(t)) \\ & - \sum_{j=1}^2 OC_j(t) - y(t)_{j,wsp} \cdot C_{SU,j} - s_{wsp,j}(t) \cdot C_{SD,j} \leq r_{wsp} \end{aligned} \quad (23)$$

$$Risk = \eta - \frac{1}{1 - \alpha} \left(\sum_{w=1}^{n_w} \pi(w) \sum_{s=1}^{n_s} \pi(s) \sum_{p=1}^{n_p} \pi(p) \right) r_{wsp} \quad (24)$$

$$r_{wsp} \geq 0 \quad (25)$$

$$\forall t \leq T, w \leq n_w, s \leq n_s, p \leq n_p$$

Constraints (23), (24) and (25) are used to model the risk, where η is an auxiliary variable and r_{wsp} is a non-negative variable.

4. Simulation studies and results analysis

The VPP under study in this paper consists of a WPP, a PV power plant, a li-ion battery bank, a micro-turbine and a diesel generator. The WPP is 25 KW, 90 rpm direct drive wind turbine with cut-in and cut-out wind speed 3.1 and 25 m/s respectively. The PV power plant is Hyundai solar module with rated capacity of 12 MW. The battery bank is li-ion 220 V and 16 A [28]. The characteristics of the micro-turbine and diesel generator are presented in Table 1. The CPP cost curve is approximated by a 10-block piecewise linear function.

Modeling the WPP and PV power plants and the market prices are discussed in [29, 30] and [31]. The wind speed and solar irradiation data, and the market prices are based on the PJM market (the Virginia Beach area) for a given day in summer (13 Jul 2005) [32].

The proposed VPP model is implemented within General Algebraic Modeling System (GAMS) on a 2.40 GHz core i5 processor with 4 GB RAM. The CPLEX12.1 solver is used to solve the proposed MILP problem.

In this case study, the Weibull density function with the shape and scale parameters of 15 and 1.75 is used to model stochastic WPP output respectively. Fig. 2, shows 10 day-ahead market price scenarios, and Fig. 3 and Fig. 4, show 10 PV and 10 WPP outputs scenarios.

By considering the above scenarios, and assuming $\beta = 0.4$ and $\alpha = 95\%$, the expected hourly profits of the VPP are shown in Fig. 5. It is worth mentioning that β controls the risk faced by the decision maker and shows the trade-off between expected profit and risk aversion. The parameter α is also chosen by decision maker (like β) and indicates the decision maker's confidence requirements regarding the expected profit.

The expected hourly profits in the first 4 hours are negative, because the day-ahead market prices are lower in those hours in most scenarios than the other hours. In these hours the electricity produced by the VPP is used to charge the battery bank. From hour 5, the expected hourly profit becomes positive due to the increase in the day-ahead market prices. The highest profit is obtained in hour 19 due to the highest market price in most scenarios at this hour. The overall expected profit throughout the day is \$10186. It means, with probability 95%, the expected profit is bigger than \$10186.

In order to evaluate the proposed stochastic optimization, this problem is modelled as the expected value model which, the random parameters are replaced with their expected values [33]. The expected value solution is \$9897 which, 2.84% lower than the stochastic solution.

Fig. 6, shows the VPP day-ahead market offerings for selected hours [in MWh]. An offering curve for each time period of the market horizon, expressing the amount of electricity that the VPP owner is willing to sell in the market at each price level. This decision is made on the first stage.

It can be seen from Fig. 6, up to the day-ahead energy price of 32 [\$/MWh], the VPP operator prefers to purchase electricity from that market the marginal costs of operating the CPPs would be higher than the day-ahead energy price. As the day-ahead price goes above 32 [\$/MWh], the amount of offered energy which the VPP operator submitted to this market goes higher to make more riskless profits from this market. In summary, the VPP activity in

the market is in direct correlation with the expected market price. So, the VPP operator sells lower amounts of electricity when the price is low, and higher amounts of electricity when the price is high.

In order to better represent the efficiency of the proposed model for optimal operation of a VPP considering the market risks, the following scenarios are simulated and discussed in details:

- 1.Small amount of stochastic unit generation and low day-ahead energy market prices.
- 2.Large amount of stochastic unit generation and high day-ahead energy market prices.
- 3.Small amount of stochastic unit generation and high day-ahead energy market prices.
- 4.Large amount of stochastic unit generation and low day-ahead energy market prices.

Fig. 7, depicts the operation of the VPP components in the first scenario. The positive values for the day-ahead and balancing markets means that the electric energy is sold to the corresponding markets. The positive value for the battery means that it is charging. As it is shown in Fig. 7, during the first seven hours, the VPPs renewable generation is sold to the balancing market; furthermore, the battery's electricity consumption is settled by purchasing energy from the day-ahead market. Despite the fact that selling electricity to the balancing market is less profitable than selling it to the day-ahead market, the VPPs operator is willing to purchase the electricity from the day-ahead market and sell the renewable power generation to the balancing market. This result is due to the effect of risk minimization in the mathematical formulation. Furthermore, since the offering curve submitted to the day-ahead energy market is independent of the renewable power generations, in some scenarios the VPPs operator should sell the renewable power generations to the balancing market. The CPPs do not get dispatched due to low day-ahead market prices.

Fig. 8, shows the optimal control strategy for the battery bank in this case study. The positive values show the battery charging, negative values show discharging and 0 shows the idle status of the battery. As it was expected, the battery is charged during low day-ahead market prices; and during 9-12 and 14-18 the battery bank is discharged to produce electricity.

The results of the second case study (with large renewable power generation and high day-ahead market prices) is illustrated in Fig. 9. In this case study, the micro-turbine and diesel produce electricity due to high day-ahead market prices. The battery is fully discharged during

the high day-ahead market prices (e.g. evening hours). The electric energy is sold to the balancing market only at hour 6, and purchased from that market at other hours in order to fulfill the day ahead offering commitments. This results to a nearly 1000 MWh sold to the day-ahead market, and 250 MWh purchased from the balancing market.

The battery optimal control strategy is shown in Fig. 10. The control signal is -1 during hours 15-20 due to high day-ahead market prices. The battery is fully charged from 1 to 5, and then gets discharged gradually during hours 8-11 to fulfil the VPPs offering commitments to the day-ahead energy market.

The simulation results for the small renewable power generations and high day-ahead energy market prices are illustrated in Fig. 11. The battery bank discharges during hours 6-11 and 15-19. The diesel and micro-turbine are committed all the time to fulfill the VPPs offering commitments to the day-ahead energy market and managing the risks associated with the low renewable power generation scenarios. Due to high day-ahead market prices, large amounts of electricity are sold to the day-ahead energy market, while the balancing market is only used to purchase electricity. The largest amount of electricity sold in day-ahead market is 157 MWh in hour 19.

The simulation results for the large renewable power generations and low day ahead energy market prices are illustrated in Fig. 12. Due to high renewable power generations and low day-ahead market prices, the diesel generator stays off and the micro-turbine generates during hours 9-11 and 18-22. The amounts of renewable power generation are sold to the balancing market. The battery bank is mostly charged with the electric energy purchased from the day-ahead energy market, and produces electricity during hours 6-11 and 16-20.

As mentioned before, these above cases studies results were obtained with the assumption: $\beta = 0.4$ and $\alpha = 95\%$. In the next section, the effect of parameter β is investigated. Furthermore, two famous risk measure criteria are compared.

4.1. The Effect of Risk Aversion factor

The VPP operator should consider the stochastic nature of day-ahead market prices and renewable power generations. In the previous section, we considered $\beta = 0.4$ and chose CVaR as the risk management model. In this section, the impact of parameter β is investigated. Moreover, the effect of the VaR as the risk management model is investigated.

Fig. 13, shows the profit histogram for $\beta = 0$ and $\beta = 1$, by considering VaR as the risk management model. It is obvious that when β is increased, the VPPs profit distribution is more concentrated, and the VPP operator would not experience low profit scenarios and would be more confident about its energy market profits. With $\beta = 0$, the VaR is not optimized, so the profit distribution has a bigger variance, although the expected profit is bigger.

Fig. 14, shows the profit histogram for $\beta = 0$ and $\beta = 1$, by considering CVaR as the risk management model. By comparing Fig. 13 and Fig. 14, it is obvious that the expected profit is lower for the CVaR; however, CVaR has a lower risk (or profit distribution variance).

Fig. 15, shows the variations of the VPPs profits, using the VaR and CVaR risk management models, as functions of β . As can be seen from this figure, for the same confidence level, α , the CVaR provides an estimate of the risk lower than the VaR value [34]; therefore, the CVaR gives a better indication of risk than that of VaR. As shown in Fig. 15, the expected profit is \$10400 for, $\beta = 0$ and \$9800 for $\beta = 1$ using CVaR as the risk management model. On the other hand, the expected profit is \$10400 for $\beta = 0$, and \$10000 for $\beta = 1$ using VaR as the risk management model.

5. Conclusion

In this paper, a two-stage stochastic mixed integer linear programming was developed to maximize the expected profit of a typical VPP operator in day-ahead and balancing energy markets considering the risk evaluation and minimization of the stochastic (or non-dispatchable) energy resources such as Wind and PV generators. In the presented VPP optimization model, the uncertainties included those of the day-ahead market prices, WPP and PV generators outputs. To model and optimize the VPP operators market risks, the CVaR was used as the risk management model. Moreover, the VPP operator was assumed to participate in both dayahead and balancing energy markets. In the day ahead market the VPP is a price-taker, due to relatively small installed capacities of its components. On the other hand, the VPP uses the balancing energy market to fulfill its offering curves which was submitted to the day ahead energy market. The case study results (for four different scenarios) showed that the CPPs started operating when day-ahead energy prices were high. In the case of low day-ahead energy prices, the balancing market was used mostly for selling the VPPs electric energy. Moreover, it was shown that when the value was increased, the VPPs profit distribution was

more concentrated and therefore, the VPP operator would not experience low profit scenarios. The comparison between the CVaR and VaR risk management models showed that CVaR could better manage the VPP operators market trading risks with respect to the chosen (and studied) market scenarios.

Indexes:

t	Index of time periods	w	Index of WPP output scenarios
p	Index of day-ahead market price scenarios	j	Index of the CPPs
s	Index of PV output scenarios	i	Index of the CPP production blocks

Constants:

\underline{g}_j	CPP minimum output	$F_{i,j}$	Slope of block i of the piecewise linear production cost function
\bar{g}_j	CPP maximum output	$ramp_{j,up}$	Ramp up limit of the CPP
$C_{SD,j}$	Shut-down cost of the CPP	$ramp_{j,down}$	Ramp down limit of the CPP
$C_{SU,j}$	Start-up cost of the CPP	\underline{g}_{batt}	Battery minimum level
A_j	Fixed cost of the CPP	\bar{g}_{batt}	Battery maximum level
$down_j$	Minimum down time of the CPP	η_c	Battery charging efficiency
up_j	Maximum up time of the CPP	η_d	Battery discharging efficiency
$u_{j,0}$	Number of periods unit j has been online to the first period of the time span	$s_{j,0}$	Number of periods unit j has been offline to the first period of the time span
$u_j(0)$	Initial commitment state of unit j		

Variables:

$G_p(t)$	Power sold (positive) or purchased (negative) in day-ahead market	$u_j(t)$	Binary variable equal to 1 if the CPP is committed at the beginning of the time period, and 0 otherwise
$y_j(t)$	Binary variable equal to 1 if the CPP is started-up at the beginning of the time period, and 0 otherwise	$z_{batt, wsp}^d(t)$	Discrete variable equal to -1 if the battery is discharged, and 0 otherwise
$s_j(t)$	Binary variable equal to 1 if the CPP is shut-down at the beginning of the time period, and 0 otherwise	$z_{batt, wsp}^c(t)$	Discrete variable equal to 1 if the battery is charged, and 0 otherwise
λ_p	Day-ahead market price	$OC_j(t)$	Total cost of the CPP
$g_{j, wsp}(t)$	CPP total power output	$P_{wsp}^{up}(t)$	Power sold in balancing market
$g_{j, wspj}(t)$	CPP power production from block i	$P_{wsp}^{down}(t)$	Power purchase in balancing market
		$g_{batt, wsp}(t)$	Battery power output

References

- [1] Peik-Herfeh M, Seifi H, Sheikh-El-Eslami M. Decision making of a virtual power plant under uncertainties for bidding in a day-ahead market using point estimate method. *International Journal of Electrical Power and Energy Systems* 2013;44(1):88–98.
- [2] Ziogou C, Ipsakis D, Seferlis P, Bezergianni S, Papadopoulou S, Voutetakis S. Optimal production of renewable hydrogen based on an efficient energy management strategy. *Energy* 2013;55:58–67.
- [3] Awerbuch S, Preston AM. *The virtual utility: accounting, technology and competitive aspects of the emerging industry*; vol. 26. Kluwer Academic Pub; 1997.
- [4] Pudjianto D, Ramsay C, Strbac G. Virtual power plant and system integration of distributed energy resources. *Renewable Power Generation, IET* 2007;1(1):10–6.
- [5] Pandžić H, Kuzle I, Capuder T. Virtual power plant mid-term dispatch optimization. *Applied Energy* 2013;101:134–41.
- [6] Mashhour E, Moghaddas-Tafreshi SM. Bidding strategy of virtual power plant for participating in energy and spinning reserve marketspart i: Problem formulation. *Power Systems, IEEE Transactions on* 2011;26(2):949–56.
- [7] Taheri H, Ghasemi H, Rahimi-Kian A, Akbari T. Modeling and optimized scheduling of virtual power plant. In: *Electrical Engineering (ICEE), 2011 19th Iranian Conference on. IEEE*; 2011, p. 1–6.
- [8] Arslan O, Karasan OE. Cost and emission impacts of virtual power plant formation in plug-in hybrid electric vehicle penetrated networks. *Energy* 2013;60:116–24.
- [9] Olivier JG, Peters JA, Janssens-Maenhout G. *Trends in global CO2 emissions 2012 report*. PBL Netherlands Environmental Assessment Agency; 2012.
- [10] Soroudi A. Robust optimization based self scheduling of hydro-thermal genco in smart grids. *Energy* 2013;61:262–71.

- [11] Soroudi A, Amraee T. Decision making under uncertainty in energy systems: state of the art. *Renewable and Sustainable Energy Reviews* 2013;28:376–84.
- [12] Garcia-Gonzalez J, de la Muela RR, Santos LM, González AM. Stochastic joint optimization of wind generation and pumped-storage units in an electricity market. *Power Systems, IEEE Transactions on* 2008;23(2):460–8.
- [13] Moghaddam IG, Nick M, Fallahi F, Sanei M, Mortazavi S. Risk-averse profit-based optimal operation strategy of a combined wind farm–cascade hydro system in an electricity market. *Renewable Energy* 2013;55:252–9.
- [14] Pandžić H, Morales JM, Conejo AJ, Kuzle I. Offering model for a virtual power plant based on stochastic programming. *Applied Energy* 2013;105:282–92.
- [15] Al-Awami AT, El-Sharkawi MA. Coordinated trading of wind and thermal energy. *Sustainable Energy, IEEE Transactions on* 2011;2(3):277–87.
- [16] Conejo AJ, Nogales FJ, Arroyo JM, García-Bertrand R. Risk-constrained self-scheduling of a thermal power producer. *IEEE Transactions on Power Systems* 2004;19(3):1569–74.
- [17] Yamin HY, Shahidehpour SM. Risk and profit in self-scheduling for gencos. *Power Systems, IEEE Transactions on* 2004;19(4):2104–6.
- [18] Rockafellar RT, Uryasev S. Optimization of conditional value-at-risk. *Journal of risk* 2000;2:21–42.
- [19] Soroudi A, Mohammadi-Ivatloo B, Rabiee A. Energy hub management with intermittent wind power. In: *Large Scale Renewable Power Generation*. Springer Singapore; 2014, p. 413–38.
- [20] Carrión M, Arroyo JM. A computationally efficient mixed-integer linear formulation for the thermal unit commitment problem. *Power Systems, IEEE Transactions on* 2006;21(3):1371–8.
- [21] Bourry F, Costa LM, Kariniotakis G. Risk-based strategies for wind/pumped-hydro coordination under electricity markets. In: *PowerTech, 2009 IEEE Bucharest*. IEEE; 2009, p. 1–8.

- [22] Soroudi A. Taxonomy of uncertainty modeling techniques in renewable energy system studies. In: *Large Scale Renewable Power Generation*. Springer Singapore; 2014, p. 1–17.
- [23] Falush D, Stephens M, Pritchard JK. Inference of population structure using multilocus genotype data: linked loci and correlated allele frequencies. *Genetics* 2003;164(4):1567–87.
- [24] Rabiee A, Soroudi A, Mohammadi-ivatloo B, Parniani M. Corrective voltage control scheme considering demand response and stochastic wind power. *Power Systems, IEEE Transactions on* 2014;PP(99):1–9. doi:[10.1109/TPWRS.2014.2316018](https://doi.org/10.1109/TPWRS.2014.2316018).
- [25] Conejo AJ, Carrión M, Morales JM. *Decision making under uncertainty in electricity markets*; vol. 153. Springer; 2010.
- [26] Mohammadi-ivatloo B, Rabiee A, Soroudi A. Nonconvex dynamic economic power dispatch problems solution using hybrid immune-genetic algorithm. *Systems Journal, IEEE* 2013;7(4):777–85. doi:[10.1109/JSYST.2013.2258747](https://doi.org/10.1109/JSYST.2013.2258747).
- [27] Soroudi A, Rabiee A. Optimal multi-area generation schedule considering renewable resources mix: a real-time approach. *Generation, Transmission Distribution, IET* 2013;7(9):1011–26. doi:[10.1049/iet-gtd.2012.0735](https://doi.org/10.1049/iet-gtd.2012.0735).
- [28] Pang C, Dutta P, Kezunovic M. Bevs/phevs as dispersed energy storage for v2b uses in the smart grid. *Smart Grid, IEEE Transactions on* 2012;3(1):473–82.
- [29] Foley AM, Leahy PG, Marvuglia A, McKeogh EJ. Current methods and advances in forecasting of wind power generation. *Renewable Energy* 2012;37(1):1–8.
- [30] Baños R, Manzano-Agugliaro F, Montoya F, Gil C, Alcayde A, Gómez J. Optimization methods applied to renewable and sustainable energy: A review. *Renewable and Sustainable Energy Reviews* 2011;15(4):1753–66.
- [31] Conejo AJ, Contreras J, Espinola R, Plazas MA. Forecasting electricity prices for a day-ahead pool-based electric energy market. *International Journal of Forecasting* 2005;21(3):435–62.
- [32] ISO. P. [online].available. 2004. URL: <http://www.pjm.com/markets-and-operations/energy/day-ahead/lmpda.aspx> . .

- [33] Morales JM, Conejo AJ, Madsen H, Pinson P, Zugno M. Virtual power plants virtual power plant. In: Integrating Renewables in Electricity Markets. Springer; 2014, p. 243–87.
- [34] Jabr RA. Robust self-scheduling under price uncertainty using conditional value-at-risk. Power Systems, IEEE Transactions on 2005;20(4):1852–8.

List of Figure Captions:

- Fig. 1. A typical schematic of the VPP
- Fig. 2. 10 day-ahead market prices scenario
- Fig. 3. 10 PV output scenarios
- Fig. 4. 10 WPP output scenarios
- Fig. 5. The expected hourly and cumulative profits
- Fig. 6. Day-ahead market offerings for the selected hours
- Fig. 7. The optimal operation of the VPPs components in the first simulation scenario
- Fig. 8. The battery's optimal control strategy
- Fig. 9. The optimal operation of VPPs components in the second simulation scenario
- Fig. 10. The battery optimal control strategy
- Fig. 11. The optimal operation of the VPPs components in the third scenario
- Fig. 12. The optimal operation of the VPPs components in the fourth scenario
- Fig. 13. The VPPs profit histogram by considering VaR (as the risk management model) for $\beta = 0$ and $\beta = 1$
- Fig. 14. The Profit histogram by considering CVaR (as the risk management model) for $\beta = 0$ and $\beta = 1$
- Fig. 15. The variation of the VPPs expected profit as a function of β

Table 1: Characteristics of Simulated CPPs

	P_{min}	P_{max}	a	b	c	RU	RD	UT	UD
	MW	MW	(\$/MW ²)	(\$/MW)	(\$)	(h)	(h)	(h)	(h)
Micro	5	28	0.00045	5.6	62	10	8	3	2
Diesel	5	30	0.001	5.66	29.48	20	20	1	1

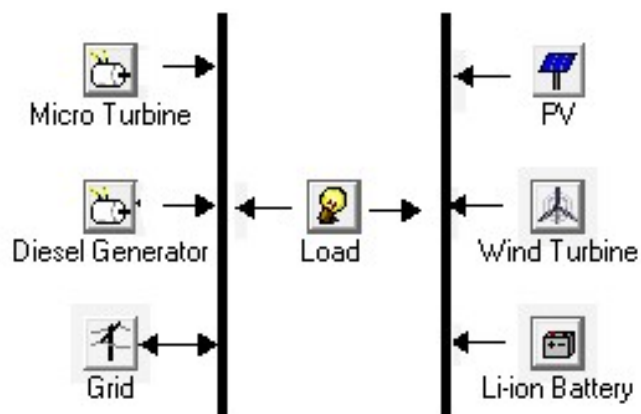

Figure 1: A typical schematic of the VPP.

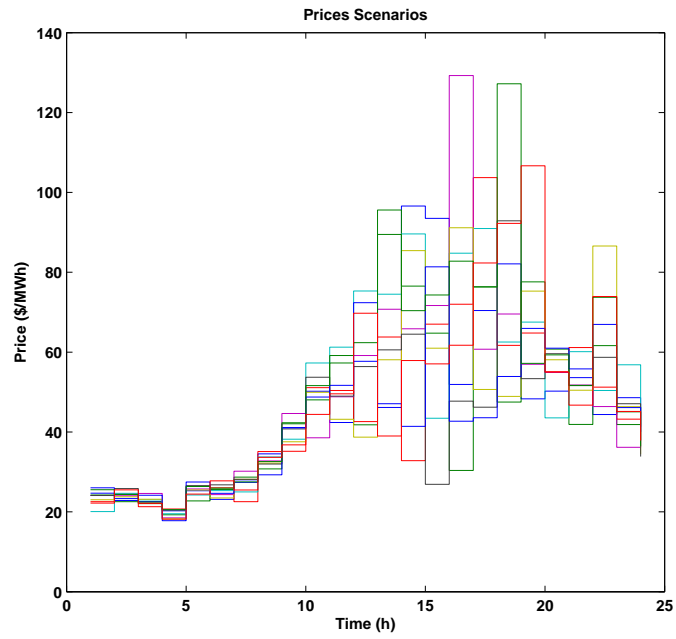

Figure 2: 10 day-ahead market prices scenario.

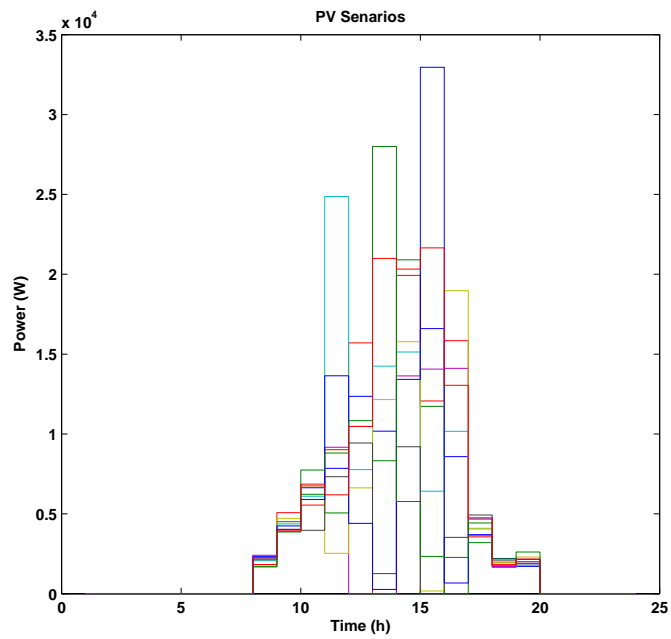

Figure 3: 10 PV output scenarios.

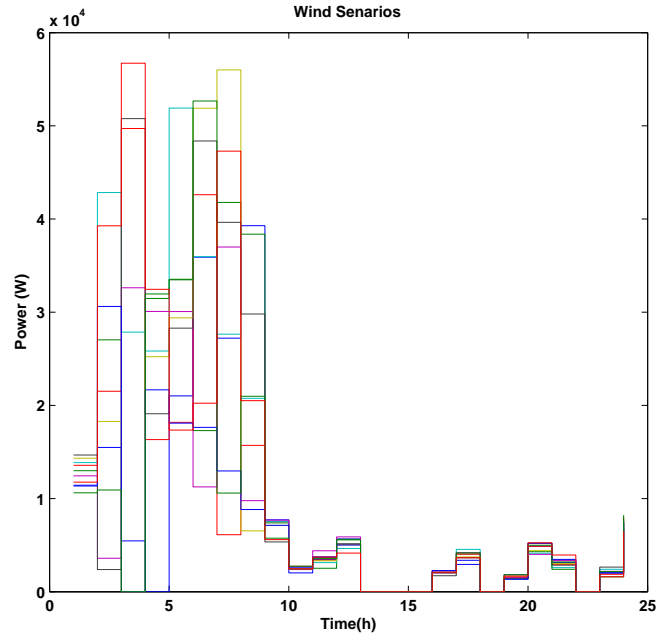

Figure 4: 10 WPP output scenarios.

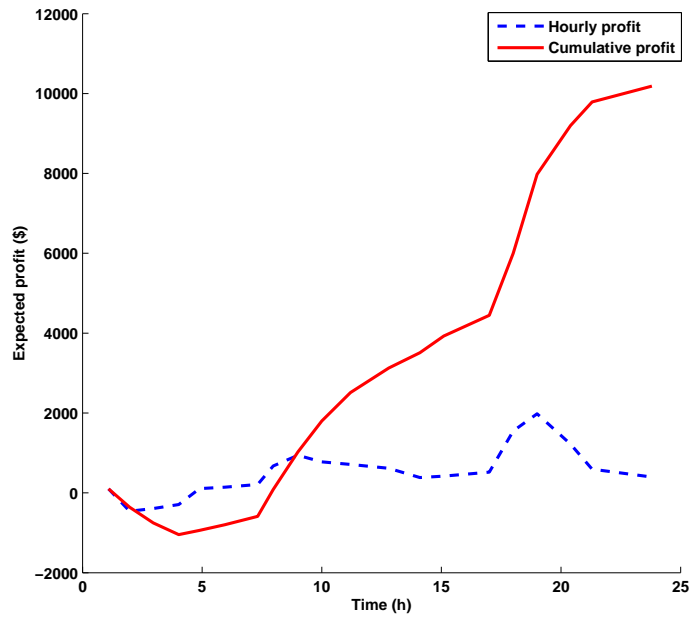

Figure 5: The expected hourly and cumulative profits.

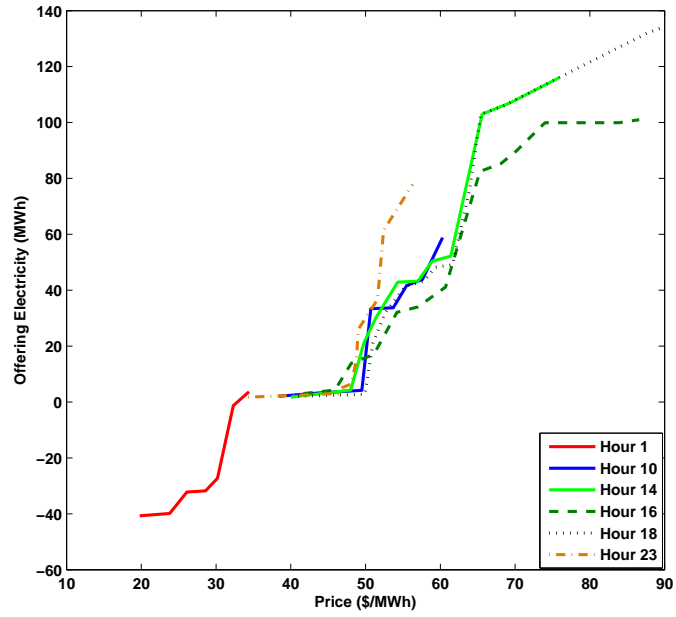

Figure 6: Day-ahead market offerings for the selected hours.

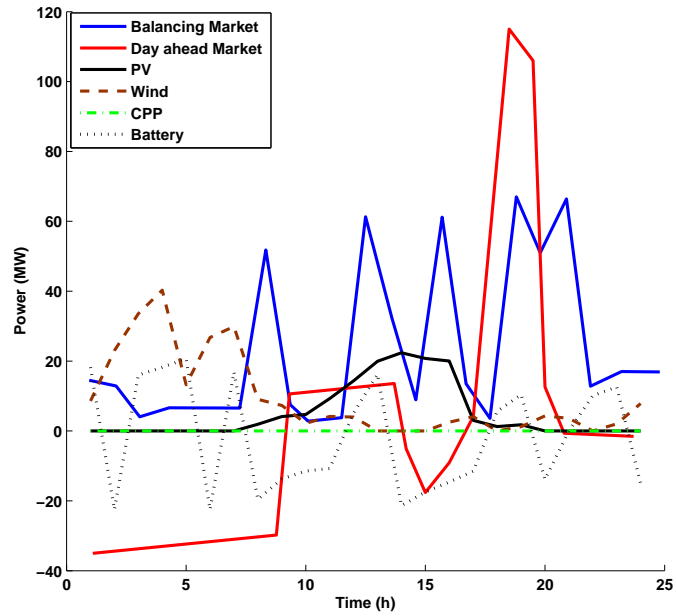

Figure 7: The optimal operation of the VPPs components in the first simulation scenario.

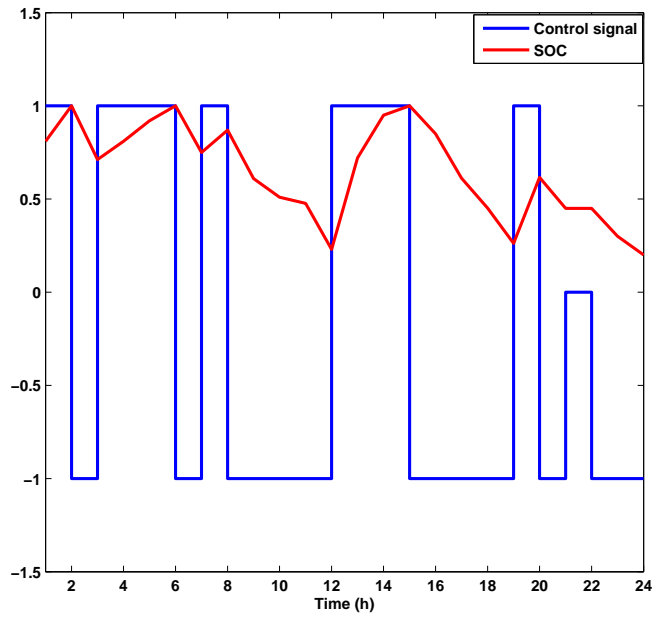

Figure 8: The battery's optimal control strategy.

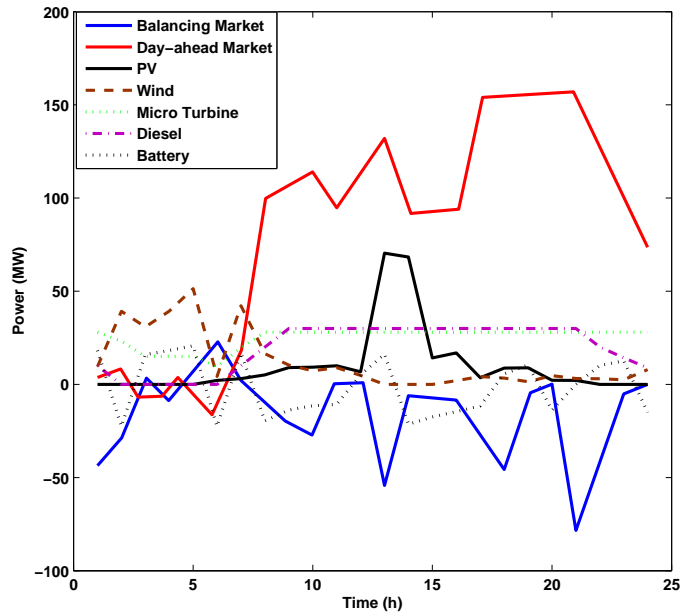

Figure 9: The optimal operation of VPPs components in the second simulation scenario.

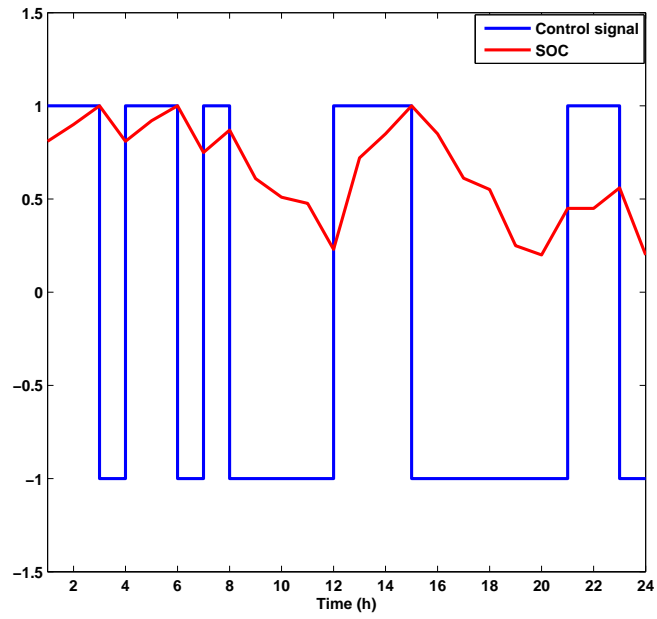

Figure 10: The battery optimal control strategy.

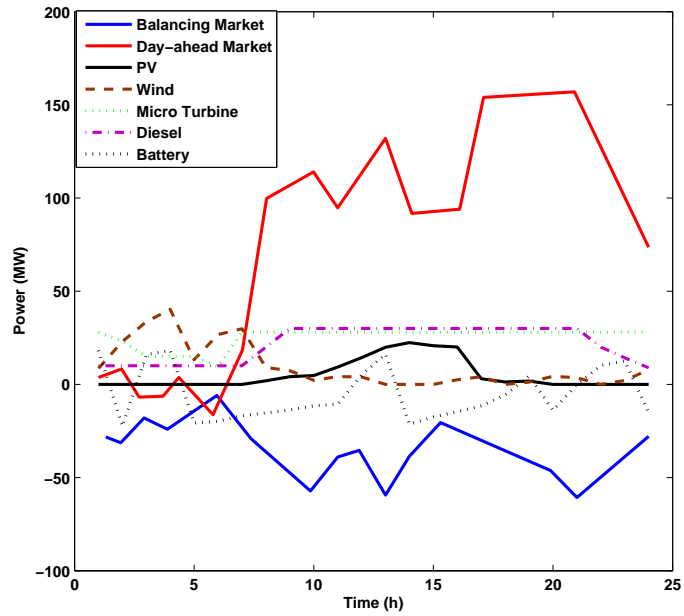

Figure 11: The optimal operation of the VPPs components in the third scenario.

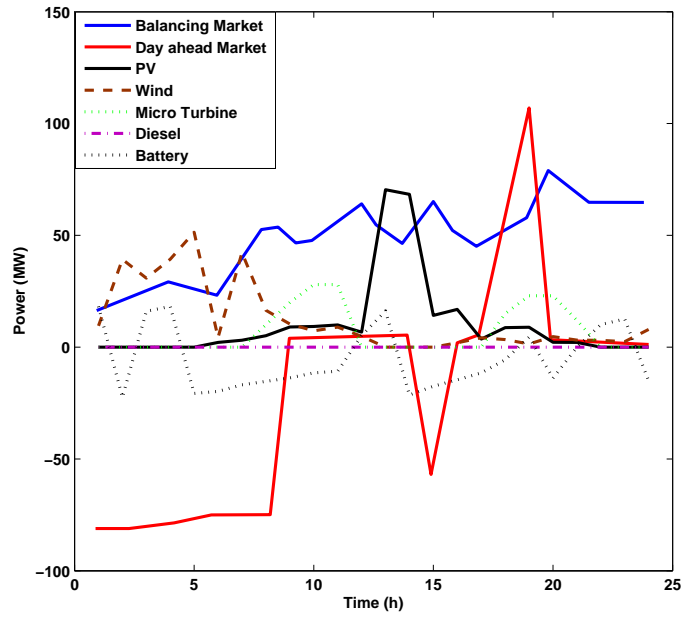

Figure 12: The optimal operation of the VPPs components in the fourth scenario.

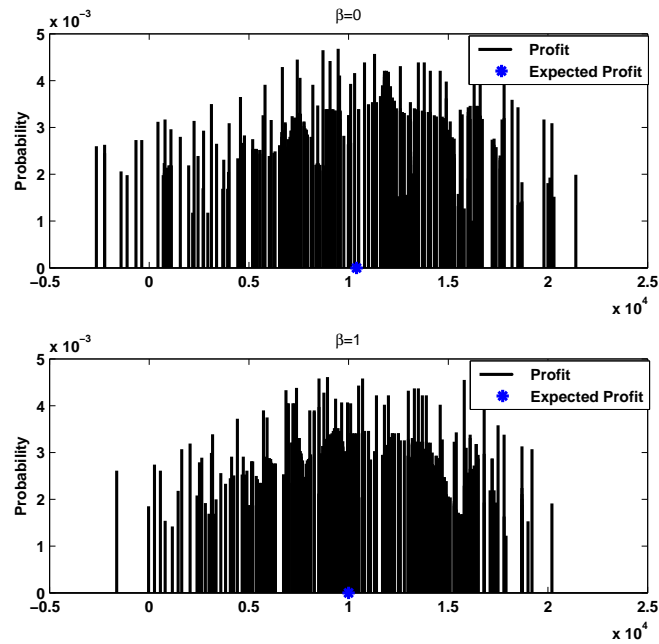

Figure 13: The VPPs profit histogram by considering VaR (as the risk management model) for $\beta = 0$ and $\beta = 1$.

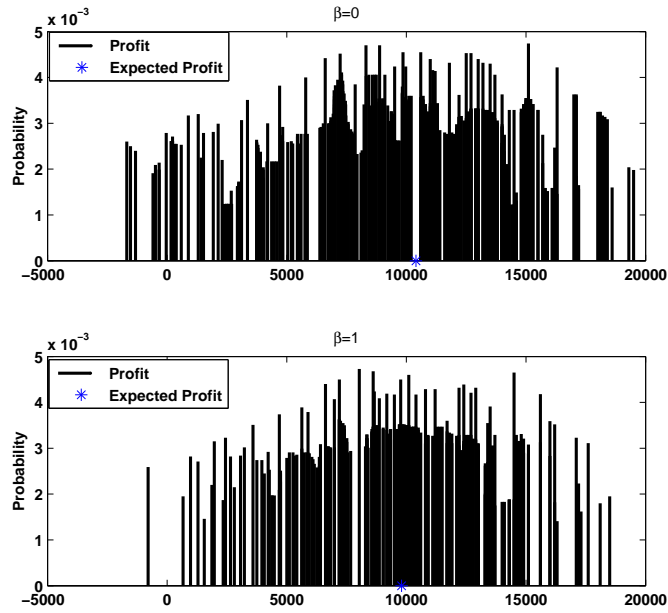

Figure 14: The Profit histogram by considering CVaR (as the risk management model) for $\beta = 0$ and $\beta = 1$.

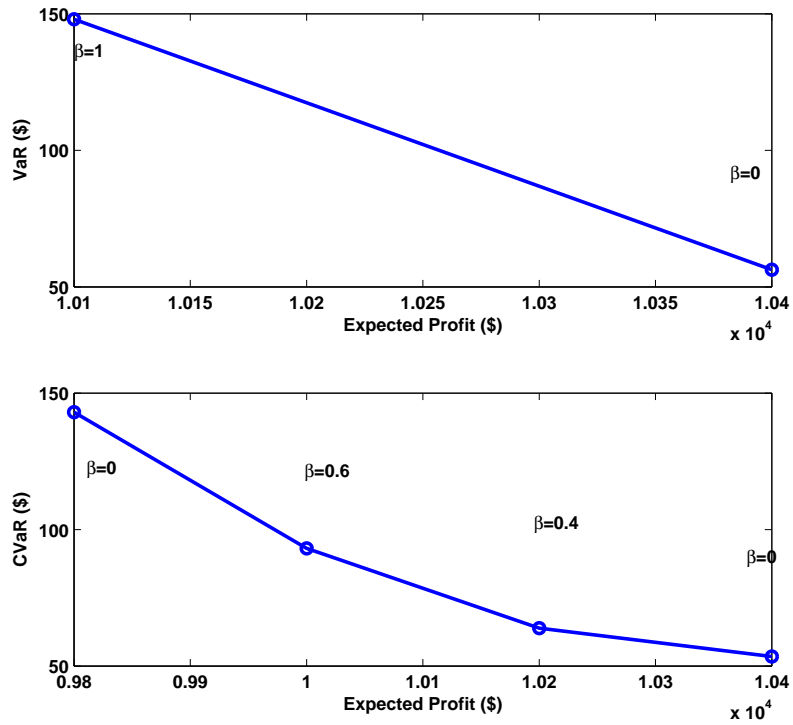

Figure 15: The variation of the VPPs expected profit as a function of β .