



Title	Bayesian maintenance decision optimisation based on computing the information value from condition inspections
Authors(s)	Zou, Guang, Banisoleiman, Kian, González, Arturo
Publication date	2021-03-26
Publication information	Zou, Guang, Kian Banisoleiman, and Arturo González. "Bayesian Maintenance Decision Optimisation Based on Computing the Information Value from Condition Inspections." SAGE, March 26, 2021. https://doi.org/10.1177/1748006X20978127 .
Publisher	SAGE
Item record/more information	http://hdl.handle.net/10197/12148
Publisher's statement	Zou G, Banisoleiman K, González A. Bayesian maintenance decision optimisation based on computing the information value from condition inspections. Proceedings of the Institution of Mechanical Engineers, Part O: Journal of Risk and Reliability. March 2021. doi:10.1177/1748006X20978127 Copyright © 2021 SAGE. Reprinted by permission of SAGE Publications.
Publisher's version (DOI)	10.1177/1748006X20978127

Downloaded 2026-05-02 00:29:45

The UCD community has made this article openly available. Please share how this access benefits you. Your story matters! (@ucd_oa)



© Some rights reserved. For more information

Bayesian Maintenance Decision Optimization based on Computing the Information Value from Condition Inspections

Guang Zou & Kian Banisoleiman

Lloyd's Register Group Limited, Southampton, United Kingdom

Arturo González

University College Dublin, Dublin, Ireland

Abstract: A challenge in marine and offshore engineering is structural integrity management (SIM) of assets such as ships, offshore structures, mooring systems, etc. Due to harsh marine environments, fatigue cracking and corrosion present persistent threats to structural integrity. SIM for such assets is complicated because of a very large number of welded plates and joints, for which condition inspections and maintenance are difficult and expensive tasks. Marine SIM needs to take into account uncertainty in material properties, loading characteristics, fatigue models, detection capacities of inspection methods, etc. Optimizing inspection and maintenance strategies under uncertainty is therefore vital for effective SIM and cost reductions. This paper proposes a value of information (VoI) computation and Bayesian decision optimization (BDO) approach to optimal maintenance planning of typical fatigue-prone structural systems under uncertainty. It is shown that the approach can yield optimal maintenance strategies reliably in various maintenance decision making problems or contexts, which are characterized by different cost ratios. It is shown that there are decision making contexts where inspection information doesn't add value, and condition based maintenance (CBM) is not cost-effective. The CBM strategy is optimal only in the decision making contexts where $VoI > 0$. The approach overcomes the limitation of CBM strategy and highlights the importance of VoI computation (to confirm $VoI > 0$) before adopting inspections and CBM.

Keywords: Value of information, Bayesian decision optimization, maintenance optimization, risk analysis, life cycle assessment

1 INTRODUCTION

Due to cyclic fatigue loading and other environmental factors, fatigue damage accumulates and structural performance degrades with service time. The core tasks of structural integrity management are developing and implementing an effective condition inspection and maintenance programme. As a result of development in non-destructive evaluation, sensing and monitoring technologies, it becomes easier to obtain crack condition information. Many researchers thus put efforts in developing CBM strategies that rely on condition information to make maintenance decisions¹⁻⁴. In marine and offshore engineering, visual inspection and magnetic particle inspection (MPI), represent commonly-adopted means to examine fatigue crack conditions. Following inspection activities, repairs or replacement may be performed to recover structural integrity and increase structural reliability, to avoid failures. Inspection data can also be employed to validate existing structural design codes or to identify potential conservatism in design codes. In addition, any human errors in the

design and manufacture process potentially can be identified by operational inspections^{5,6}.

The challenge is that inspection and maintenance tasks are cumbersome and expensive work for large steel structures with a large number of fatigue-prone structural details, e.g., ship structures, offshore oil platforms and offshore wind farms, etc. There are many stress concentration areas in these structures (e.g. in the vicinity of joints, connections, openings, etc.), where fatigue cracks are likely to occur and propagate leading to structural integrity loss. The costs associated with inspection and repair activities are often responsible for a large part of life cycle costs (LCC) of marine structures, due to a large number of areas susceptible to fatigue cracks, limited access to the damage locations, significant downtime loss, etc.⁷. In this regard, formulation of an efficient inspection and maintenance strategy is crucial for reducing LCC, improving structural reliability and mitigating failure risk. Planning and optimizing lifetime maintenance interventions holistically at the

beginning of service life can improve maintenance efficiency significantly.

Optimal maintenance planning needs to take sources of uncertainty into account, e.g. the uncertainty associated with material properties, fatigue loading and resistance computation, crack detection and measurement, etc. Probabilistic modelling and reliability methods have been applied to tackle with uncertainties consistently in maintenance modelling and optimization of structural assets, e.g. in offshore engineering, nuclear engineering and bridge engineering, etc. ⁸⁻¹¹. By integration of probabilistic modelling with life cycle cost modelling, cost based probabilistic optimization approaches have also been developed in support of rational and optimal maintenance decision-making under uncertainty ^{5, 12, 13}. A limitation of these probabilistic optimization approaches is that a decision rule need to be set up in advance and then optimization is performed on the maintenance strategy defined by the decision rule ¹⁴. In most of these studies, the predefined decision rule is that: carry out maintenance if it is found by an inspection that the crack size exceeds a threshold value and do nothing otherwise, i.e. a CBM strategy. Then the CBM strategy with the optimal threshold is sought for ¹⁵. Under a specific decision rule or strategy, the maintenance decision making is constrained and a really optima decision may not be found in some maintenance decision making problems. In addition, there is also uncertainty in crack detection and measurement techniques, and thus a maintenance decision made based only on inspection information may not be really reliable. Moreover, it is likely that inspection information does not add value

and the CBM strategy which relies on inspection information isn't the optimal strategy in some maintenance decision making problems.

The VoI provides a rational metric for quantifying the add value brought by information to decision making under uncertainty. The costs of obtaining information are justified only when $VoI > 0$. Without explicit computation of the VoI, maintenance decision makers in face of uncertainty often pursue more information and involve more information collecting activities. For example, when planning maintenance interventions, decision-makers often develop inspection or monitoring programme and rely on inspection or monitoring information to make decisions, i.e. adopting CBM strategy. However, it should be noted that the CBM strategy is cost-effective only when VoI is quantified and it is confirmed that $VoI > 0$.

Only by explicit VoI computation it is possible to judge whether the information provided by envisaged inspection or monitoring activities add value or not. If $VoI = 0$, then there is no need to carry out inspections and it is better to make maintenance decisions based on existing crack information. In the last decade, VoI computation methods have been proposed in structural engineering to quantify the added value brought by condition inspection or monitoring activities before they are implemented ^{16, 17} and accordingly optimize inspection or monitoring strategies ¹⁸⁻²¹. There are however few studies on relating VoI computation to optimal maintenance planning under uncertainty.

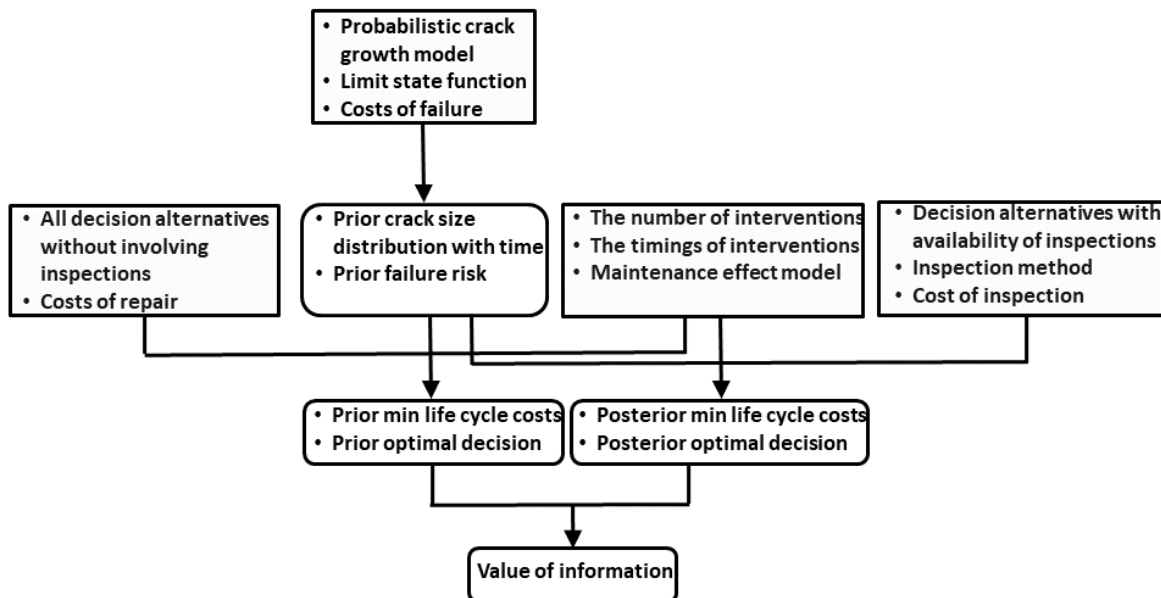

Figure 1. A flowchart of the proposed approach

In this paper, a Bayesian maintenance decision optimization (BDO) approach via computing the VoI from condition inspections is proposed. The ap-

proach is applied to various maintenance decision making problems characterized by different cost ratios. It is shown that the approach is reliable in yield-

ing optimal maintenance decisions associated with the minimum LCC in various decision problems, based on explicit VoI computation and modelling of available decision alternatives. It is found that the value of inspection information is equal to zero in some maintenance decision making problems and the CBM strategy is not the optimal strategy for such problems. The proposed maintenance decision optimization and VoI computation are carried out at the beginning of service life, in support of rational and optimal maintenance planning under uncertainty. The proposed approach can be divided into 4 steps which are illustrated by Figure 1. Step 1: initial crack size distribution with time and initial failure risk are obtained by Monte Carlo simulations based on a probabilistic crack growth model and associated input variables. Herein the simulated crack size distribution represents crack information prior to condition inspections (i.e. prior information). Step 2: the LCC associated with all maintenance decision alternatives without involving inspections (Table 4) are computed based on prior crack size distribution. The decision associated with the minimum LCC is the prior optimal decision. The min LCC is the prior min LCC without involving inspections. The computations are defined as prior decision optimization. Step 3: the LCC associated with all maintenance decision with the availability of inspections (Table 5) are computed based on posterior crack size distribution considering inspection results. The decision associated with the minimum LCC is the posterior optimal decision. The min LCC is the posterior min LCC with availability of inspections. The computations are defined as posterior decision optimization. Step 4: The VoI is the difference between the prior min LCC and posterior min LCC. If $\text{VoI} = 0$, then the obtained prior optimal maintenance decision without involving inspections (in Step 2) is the optimal decision. On the other hand, if $\text{VoI} > 0$, then the obtained posterior optimal maintenance decision with availability of inspections (in Step 3) is the optimal decision. Therefore, the proposed approach can give optimal strategies for various maintenance decision problems, while the CBM strategy is efficient only in problems where $\text{VoI} > 0$. The proposed approach overcomes the limitation of CBM.

It should be noted that this study is different from those studies concentrating on comparing two specific maintenance strategies, e.g. CBM and time based maintenance (TBM)^{3, 22}. This study is in a Bayesian decision analysis perspective, and considers all available maintenance decision alternatives (Tables 4 and 5) in both prior and posterior decision optimizations.

The rest of the paper is organized as follows. Section 2 introduces a representative marine structural model under investigation, and some of its design

considerations. Section 3 proposes a probabilistic crack growth modelling approach to the fatigue deterioration. Section 4 formulates the maintenance planning problem and discusses the maintenance effect model and inspection techniques under consideration. Section 5 formulates the methodology of Bayesian maintenance decision optimization and VoI computation. In particular, all maintenance decisions alternatives in prior optimization and posterior optimization are analyzed, and the approach to calculate the expected LCC associated with a maintenance decision or strategy is developed. Section 6 gives the derived optimal decisions and VoI under different cost ratios (which represent different maintenance decision making contexts) and inspection techniques (which provide different crack information). The cost ratios and maintenance decision making contexts where $\text{VoI} = 0$ and CBM is not the optimal strategy are discussed in detail. The impacts of inspection techniques on the VoI are shown. Section 7 draws conclusions from the study.

2 FATIGUE-SENSITIVE STRUCTURAL COMPONENTS

Marine and offshore structures are typically exposed to sea and wave environments, which can cause fatigue crack initiation and growth in structural components, especially in the areas with stress concentration. Figure 2 shows a typical fatigue-prone stiffened plate under fatigue loading caused by waves, which are common in marine vessels³. Normally, stiffeners and frames improve plate stability, but can lead to a fatigue performance decrease, due to stress concentration, poor welding quality and presence of initial flaws, etc. These are typical trigger factors of crack initiation.

In this study, we investigate the fatigue reliability of the structure and optimal maintenance strategies contributing to reliability growth with reasonably low maintenance costs. In this example the required service life is $T_{SL} = 20$ years. The frequency of wave loading that the structure experiences is about 0.16 Hz²³, which means that the annual fatigue load cycles are approximately equal to $N_0 = 5 \times 10^6$. At the design stage, the fatigue limit state has been checked against design codes. Fatigue resistance of the structure detail is rated as F class and a representative S-N curve is given by a classification society²⁴. The structure is designed with a fatigue design factor (FDF) of 3 and the plate thickness is $T = 25$ mm. Table 1 lists the design parameters, in which \bar{a}_1 and \bar{a}_2 are fatigue strength coefficients, and m_1 and m_2 are fatigue strength exponents according to²⁴.

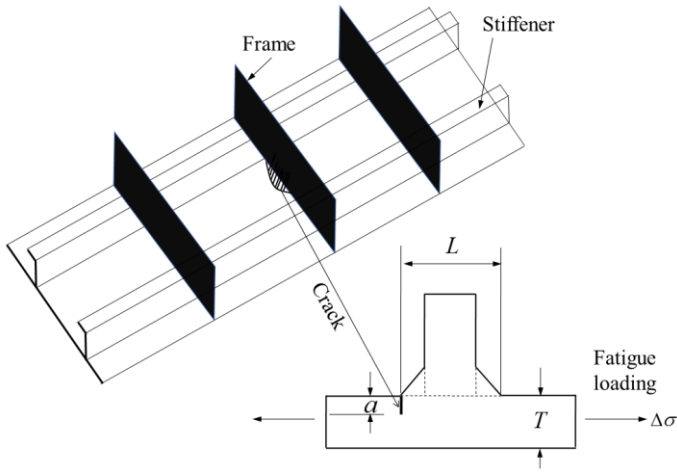

Figure 2. The structural model

Table 1. Design parameters of the structural model

Parameter	Unit	Value
T_{SL}	Year	20
N_0	Cycle	5×10^6
FDF	-	3
T	mm	25
$\log_{10} \bar{a}_1$	[N, mm]	11.855
$\log_{10} \bar{a}_2$	[N, mm]	15.091
m_1	-	3
m_2	-	5
m	-	3
ΔK_{th}	[N, mm]	0
a_c	mm	25
Δt	Years	10/7

3 FATIGUE DETERIORATION MODELLING

Herein a probabilistic fracture mechanic model is employed for fatigue crack growth modelling. The obtained crack size predictions represent prior crack information (before adopting inspections), which are basis of prior maintenance decision optimization.

From a fracture mechanics perspective, there are typically initial flaws or cracks (the initial size a_0) in structures. Initial cracks propagate under a stress range and then reach a critical size a_c , which defines the final failure (Figure 3). The critical crack size can be defined based on serviceability analysis, e.g. the plate in Figure 3 would not be watertight if a through-thickness crack occurs. Hence, the critical crack size a_c is set to be equal to the plate thickness, i.e. $a_c = T$.

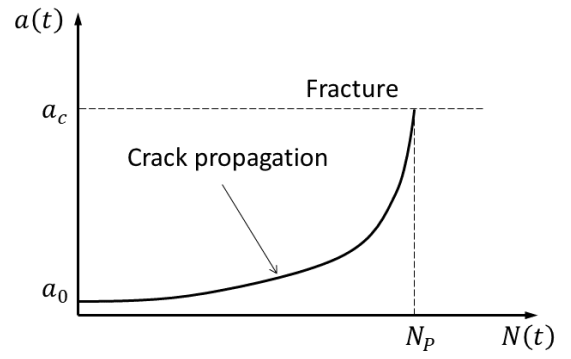

Figure 3. An illustration of the crack propagation process

Based on one-dimensional Paris's law²⁵, the relationship between crack growth rate and local stress range is given by Equation (1).

$$\frac{da}{dN} = C \Delta K^m, \Delta K_{th} \leq \Delta K \leq K_{mat} \quad (1)$$

where a is crack depth; N is the number of fatigue load cycles; da/dN is crack propagation rate; C and m are material parameters; ΔK is the range of stress intensity factor; K_{mat} is material fracture toughness; ΔK_{th} is the threshold value of ΔK .

The stress intensity factor range ΔK is given by Equation (2). The values of the input parameters are listed in Table 1.

$$\Delta K = \Delta \sigma Y(a) \sqrt{\pi a} \quad (2)$$

where $Y(a)$ is geometry function and $\Delta \sigma$ is stress range.

Table 2. Statistical data for random variables

Variable	Distribution	Unit	Mean	SD
a_0	Exponential	mm	0.04	0.04
$\log_{10} C$	Normal	[N, mm]	-12.74	0.11
B	Normal	-	1.00	0.15
a_d	Exponential	mm	0.89/4.35	0.89/4.35

Essentially, crack propagation is a stochastic process and therefore main sources of uncertainty in the Paris's model (Equations (1) and (2)) need to be taken into account, i.e. uncertainty associated with the initial crack size a_0 , crack growth rate C , and stress range $\Delta \sigma$. In this paper, uncertainty in the initial crack size a_0 is modelled via an exponential distribution with a mean value $E(a_0) = 0.04$ ²³. Uncertainty associated with calculation of stress range $\Delta \sigma$ generally comes from the adopted wave load characterization method, structural response calculation method, stress concentration factor calculation method, etc. Herein the uncertainty in the stress

range $\Delta\sigma$ is modelled with a normally distributed variable B . The statistical descriptors for B are: the mean value $E(B) = 1$ and the standard deviation (SD) $\mu(B) = 0.15$ ¹⁰. The crack growth rate C is generally regarded as a material property, although it is affected by other factors as well. For marine structures, the crack growth rate C is often modelled to be lognormally distributed²³ while $m = 3$. The statistical descriptors of all variables are summarized in Table 2.

We then integrate the probabilistic crack growth model into a probabilistic optimization framework, by which the expected LCC associated with all available maintenance strategies are evaluated and the optimal strategy is derived. More sophisticated crack growth models are available²⁶. However, when these models are integrated into a probabilistic optimization framework, computational costs increase significantly.

4 MAINTENANCE PROBLEM FORMULATION

The actual fatigue life of the structure at the operation stage may be shorter than that predicted by the S-N approach at the design stage due to presence of initial cracks. S-N curves are typically obtained based on specimen test data with smaller initial flaws and the actual loading conditions can be different from those adopted at the design stage. Developing and implementing a SIM strategy at the operation stage, especially an effective maintenance strategy, is therefore important for keeping structural integrity and safe operation of the asset. In this paper (Section 5), we develop a Bayesian maintenance decision optimization (BDO) approach to derive the optimal maintenance decision (or strategy) and quantify the expected information value from envisaged condition inspections.

The proposed approach is applied to investigating the effects of both one and two maintenance interventions ($n = 1$ or 2) on structural reliability and LCC. The maintenance intervention(s) is/are scheduled to service year(s) with equal intervals^{27, 28}. The time intervals (Δt) and intervention timings (t_1, t_2) are listed in Table 3.

Table 3. The number of maintenance interventions and time intervals of interventions

n	Δt (years)	t_1, t_2 (year)
1	10	10 th
2	7	7 th , 14 th

A renewal maintenance model is adopted, i.e. after repair the structural detail is renewed to its initial state²⁸⁻³⁰. The maintenance strategies derived by the

BDO approach are compared with three maintenance strategies: CBM, time-based maintenance (TBM) and no action (NA). The efficiencies of these strategies are evaluated using the metric of LCC (Section 5). Under TBM, inspections are not involved and the structure is maintained periodically. Under CBM, inspections are performed periodically and maintenance is carried out when necessary.

The effects of two inspection methods are investigated: MPI and visual inspection (VI). The mean values of the detectable crack size (a_d) of MPI and VI are 0.89 mm and 4.35 mm respectively^{11, 31}. It is very clear that a smaller value of a_d signifies a higher capability and reliability in crack detection.

5 BDO AND VOI COMPUTATION

Bayesian decision optimization (BDO) and value of information (VoI) computation are performed at the beginning of the operation stage to develop optimal inspection and maintenance strategies. A limit state function is given by below Equation (3).

$$h(t) = a_c - a(t) \quad (3)$$

where $h(t) \leq 0$ signifies failure. As discussed in Section 3, $a_c = T$.

Based on the limit state function, the probability of failure by time t is obtained by Equation (4). Note that the lifetime failure probability is $pf(T_{SL})$. Reliability index is calculated by Equation (5), where $\Phi^{-1}[\cdot]$ is the inverse function of standard normal cumulative density function. The failure probability and reliability index are calculated by Monte Carlo simulations³².

$$pf(t) = P(h(t) < 0) \quad (4)$$

$$\beta(t) = -\Phi^{-1}(pf(t)) \quad (5)$$

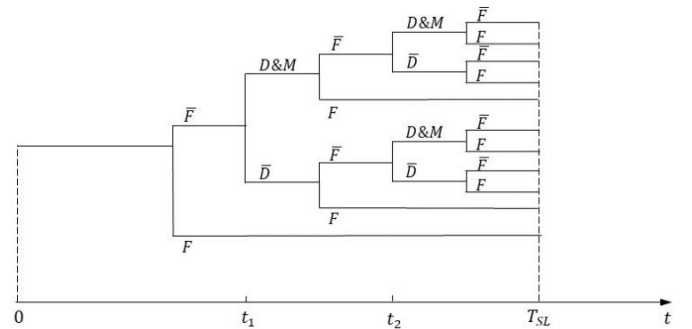

Figure 4. Decision tree analysis of two maintenance interventions adopting [CBM, CBM]

In order to evaluate the effects of different maintenance strategies on LCC, the probabilities of failure, of inspection (if any) and of maintenance need to be formulated, taking scheduled maintenance into account. The probabilities are formulated based on decision tree analysis. For example, Figure 4 shows the decision tree analysis of two maintenance interventions scheduled to t_1 and t_2 respectively, both of which adopt CBM, denoted by [CBM, CBM]. In Figure 4, ‘F’, ‘D’ and ‘M’ mean the event of failure, detection and maintenance respectively while \bar{F} and \bar{D} denote survival and no detection respectively. Note that the structure of the decision tree is different when different maintenance strategies are adopted. Based on the decision tree, the probability of failure is calculated by summation of the probability of failure associated with all failure branches in the figure.

This paper addresses structural maintenance at the operation stage of the asset. Thus, design and construction costs are the same for all maintenance strategies and not included in the LCC analysis. The LCC, given by Equation (6), is comprised of the costs of failure, inspections and maintenance, given by Equations (7) – (9) respectively.

$$LCC = C_I + C_M + C_F \quad (6)$$

$$C_F = pf^n \cdot c_{f0} \quad (7)$$

$$C_I = \sum_{k=1}^n pi^k \cdot c_{i0} \cdot \frac{1}{(1+r)^{t_k}} \quad (8)$$

$$C_M = \sum_{k=1}^n pm^k \cdot c_{m0} \cdot \frac{1}{(1+r)^{t_k}} \quad (9)$$

where pf^n is the probability of failure taken into account the effect of n maintenance interventions; c_{f0} is economic loss of failure; pi^k and pm^k are the probability of inspection and maintenance at the k th maintenance intervention; t_k is the time of the k th maintenance intervention; c_{i0} and c_{m0} are the costs associated with an inspection and an maintenance activity respectively, and; r is average annual discount rate of money.

By quantifying the information value brought by envisaged inspections explicitly, it is possible to determine whether to adopt a maintenance strategy utilizing inspection information or a maintenance strategy based on prior information without any inspection. The VoI is computed as utility increments due to availability of the information³³. Herein the VoI and utility increments are quantified via LCC reductions, given by Equation (10), where LCC_{\min} is the LCC associated with the prior optimal maintenance decision, and LCC'_{\min} is the LCC as-

sociated with the posterior optimal maintenance decision. The LCC_{\min} and LCC'_{\min} are obtained by systematic Bayesian decision optimization.

$$VoI = LCC_{\min} - LCC'_{\min} \quad (10)$$

5.1 Prior decision optimization

Herein ‘prior’ means prior to the availability of additional information, e.g. without involving inspections. The available maintenance decision (or strategy) alternatives are given by Table 4. Note that there are 2 decision alternatives for each intervention: ‘T’ (time-based maintenance) and ‘N’ (no action) and thus 4 alternative decisions for two interventions. The LCC associated with all these decision alternatives are calculated by Equations (6) – (9) based on prior crack information, i.e. the crack growth simulated by the probabilistic model in Section 2. The maintenance strategy associated with the minimum LCC is the prior optimal strategy d_{opt} (Equation (11)). The prior minimum life cycle costs LCC_{\min} are obtained by Equation (12).

$$d_{\text{opt}} = \arg \min_{d_i} LCC(d_i) \quad (11)$$

$$LCC_{\min} = LCC(d_{\text{opt}}) \quad (12)$$

Table 4. Maintenance decision alternatives in prior decision optimization

The number of interventions (n)	Decision alternatives (d_i)
1	T (time-based maintenance), N (no action)
2	(T, T), (T, N), (N, T), (N, N)

5.2 Posterior decision optimization.

Table 5. Maintenance decision alternatives in posterior decision optimization

The number of interventions (n)	Decision alternatives (d'_i)
1	T (time-based maintenance), N (no action), C (condition based maintenance)
2	(T, T), (T, C), (T, N), (C, T), (C, C), (C, N), (N, T), (N, C), (N, N)

Herein ‘posterior’ means posterior to the availability of additional inspection information. The available maintenance decision (or strategy) alternatives are given by Table 5. Note that there are 3 decision al-

ternatives for each intervention: ‘T’ (time-based maintenance), ‘N’ (no action) and ‘C’ (condition-based maintenance) and thus 9 alternative decisions for two interventions. It should be stressed that even when inspection information is available, the decision alternatives without utilizing inspection information (e.g. (T, T), (T, N), (N, T), (N, N)) should be considered in decision optimization, because inspection information may does not add value. The LCC associated with all these decision alternatives are calculated by Equations (6) – (9) based on posterior crack information, i.e. integration of the crack growth model prediction and inspection information. The maintenance strategy associated with the minimum LCC is the posterior optimal strategy d'_{opt} (Equation (13)). The posterior minimum life cycle costs LCC'_{min} are obtained by Equation (14).

$$d'_{opt} = \arg \min_{d'_i} LCC(d'_i) \quad (13)$$

$$LCC'_{min} = LCC(d'_{opt}) \quad (14)$$

Based on Equations (10) – (14), the below conclusions can be drawn.

- If the optimal maintenance decisions (or strategies) with or without the inspection information are the same, then $VoI = 0$, which means that there is no need in obtaining the inspection information.
- Inspection information adds value (i.e. $VoI > 0$) only when the optimal maintenance decision (or strategy) with the availability of the inspection information is different from the prior optimal decision without the inspection information.

Herein the cost ratio $\lambda = c_{m0}/c_{f0}$ is identified as the main parameter charactering maintenance decision making context. Different λ values essentially mean different decision making problems and contexts. The VoIs are computed and the optimal maintenance strategies are derived under different maintenance decision making contexts, i.e. different λ values (0.001, 0.01, 0.1, 0.4). A small λ value represents the decision contexts where the costs of an maintenance intervention is very small compared with the costs of failure, while a relatively large λ value indicates the contexts where the costs of an maintenance intervention is relatively high. The costs of failure is set as a reference value $c_{f0} = 10000$, and the costs of an inspection is $c_{i0} = 5$. It is considered that the value of c_{i0} is small, compared with the value of c_{m0} .

6 RESULTS AND DISCUSSIONS

Table 6 gives the prior failure probabilities without any maintenance in different service years. Clearly, the failure probabilities would become decreased with maintenance. The failure probabilities would become lower and lower with a larger number of maintenance interventions. Generally, the TBM strategy results in lower failure probabilities than the CBM strategy, but also leads to higher maintenance costs. Hence, a trade-off between failure probability and maintenance costs needs to be achieved. The proposed approach is employed to derive the optimal strategies with the best trade-off under various decision making contexts.

Tables (7) – (9) provide the results when the number of scheduled maintenance $n = 1$. Tables (7) and (8) give the life cycle costs and value of information when adopting MPI and VI respectively, where $LCC(CBM)$ denotes the life cycle costs when CBM is adopted, LCC_{min} and LCC'_{min} are the minimum life cycle costs obtained by the proposed prior and posterior decision optimization respectively. Table 9 summarizes the optimal maintenance strategies derived by the proposed BDO approach, when MPI is considered (BDO(MPI)), VI is considered (BDO(VI)) and both of the inspection methods are considered (BDO) respectively.

Tables (10) – (12) provide the results when the number of scheduled maintenance $n = 2$. Similarly, Tables (10) & (11) give the life cycle costs and value of information when adopting MPI and VI respectively. Table 12 summarizes the optimal maintenance strategies derived by the proposed BDO approach when MPI, VI and both of them are considered. In Table 12, the strategy [CBM(MPI), NA] means that CBM strategy and MPI is scheduled for the 1st maintenance intervention, and NA is adopted for the 2nd maintenance intervention.

Table 6. Prior failure probabilities without any maintenance in different service years.

Service year (t)	7	10	14	20
Initial failure probability (pf)	$2.3 \cdot 10^{-4}$	$4.0 \cdot 10^{-3}$	$2.9 \cdot 10^{-2}$	0.13

Table 7. Life cycle costs (LCC) and value of information (VoI) (MPI, $n=1$)

λ	LCC_{min}	LCC'_{min}	$LCC(CBM)$	VoI
0.001	92.9	65.1	65.1	27.8
0.01	182.5	99.1	99.1	83.4
0.1	1078.8	439.8	439.8	639.8
0.4	1329.4	1329.4	1575.4	0

Table 8. Life cycle costs (LCC) and value of information (VoI) (VI, $n=1$)

λ	LCC_{\min}	LCC'_{\min}	LCC(CBM)	VoI
0.001	92.9	92.9	663.2	0
0.01	182.5	182.5	669.3	0
0.1	1078.8	730.0	730.0	348.8
0.4	1329.4	932.3	932.3	397.1

Table 9. Optimal maintenance strategies ($n=1$)

λ	BDO (MPI)	BDO (VI)	BDO
0.001	CBM	TBM	CBM(MPI)
0.01	CBM	TBM	CBM(MPI)
0.1	CBM	CBM	CBM(MPI)
0.4	NA	CBM	CBM(VI)

Table 10. Life cycle costs (LCC) and value of information (MPI, $n=2$)

λ	LCC_{\min}	LCC'_{\min}	LCC(CBM)	VoI
0.001	15.4	15.4	19.7	0
0.01	105.3	77.7	77.7	27.6
0.1	1004.7	339.2	657.9	665.5
0.4	1329.4	852.5	2592.0	476.9

Table 11. Life cycle costs (LCC) and value of information (VI, $n=2$)

λ	LCC_{\min}	LCC'_{\min}	LCC(CBM)	VoI
0.001	15.4	15.4	185.8	0
0.01	105.3	105.3	203.9	0
0.1	1004.7	384.1	384.1	620.6
0.4	1329.4	984.8	984.8	344.6

Table 12. Optimal maintenance strategies ($n=2$)

λ	BDO (MPI)	BDO (VI)	BDO
0.001	(TBM, TBM)	(TBM, TBM)	(TBM, TBM)
0.01	(CBM, CBM)	(TBM, TBM)	[CBM(MPI), CBM(MPI)]
0.1	(CBM, NA)	(CBM, CBM)	[CBM(MPI), NA]
0.4	(CBM, NA)	(CBM, CBM)	[CBM(MPI), NA]

It can be seen from the Tables that the VoI provided by an inspection can be zero. e.g. when $\lambda = 0.4$ and MPI is considered (Table 7); when $\lambda = 0.001$ or 0.01 and VI is considered (Table 8). The VoI provided by two inspections can also be zero. e.g. when $\lambda = 0.001$ and MPI is considered (Table 10); when $\lambda = 0.001$ or 0.01 and VI is considered (Table 11). In addition, when two inspections are considered, the VoI provided by one of the inspections can be zero (i.e. one of the inspections is not necessary). For example, when $\lambda = 0.1$ or 0.4 and MPI is considered (Table 12), the maintenance strategy derived by the proposed approach is [CBM,

NA], which means that No Action (NA) is a more optimal strategy than CBM for the 2nd maintenance intervention and thus an inspection for the 2nd intervention is not necessary. Therefore, it is important to perform VoI computation and to confirm that $VoI > 0$ before adopting inspections and CBM.

The tables clearly show that when $VoI = 0$, the optimal maintenance strategies obtained by the proposed approach is not CBM. For example, when $\lambda = 0.4$ and MPI is considered, $VoI = 0$ (Table 7) and the optimal strategy is NA (Table 10); when $\lambda = 0.001$ or 0.01 and VI is considered, $VoI = 0$ (Table 8), and the optimal strategy is TBM (Table 9). Hence, when $VoI = 0$, the optimal maintenance strategies derived by the proposed approach is the prior optimal maintenance strategies without involving inspections (e.g. NA or TBM). When $VoI > 0$, the obtained optimal maintenance strategies are CBM. These results show that the proposed approach can result in optimal maintenance strategies reliably (whether $VoI > 0$ or $=0$) and applicable to a wide range of maintenance decision making contexts, while the CBM strategy is not optimal in decision making contexts where $VoI = 0$.

Generally, $VoI = 0$ indicates that the information provided by the given inspection method (characterized by a specific detectable crack size (a_d)) does not add value to the given maintenance decision making problem (characterized by a specific λ value). For such a decision problem, the prior optimal maintenance decision derived based on prior crack growth predictions without involving inspections (e.g. NA or TBM) is the optimal decision, and CBM (e.g. conditional replacement based on crack detection threshold a_d) is not the optimal decision. Specifically, when $\lambda = 0.001$ (or 0.01) and VI is considered (Table 8), the costs of a maintenance intervention is relative cheap and thus more maintenance is desirable. However, the mean detectable of VI is relatively large ($a_d = 4.35$ mm) and thus the probability of detection and maintenance would be low (leading to insufficient maintenance). So, in these maintenance decision making contexts ($\lambda = 0.001$ or 0.01), VI is not a good choice ($VoI = 0$) and the optimal strategy is TBM (Table 9). On the other hand, when $\lambda = 0.4$ and MPI is considered (Table 7), the costs of a maintenance intervention is relatively high and thus less maintenance is desirable. However, the mean detectable of MPI is very small ($a_d = 0.89$ mm) and the probability of detection and maintenance would be high (leading to excessive maintenance). So, in this maintenance decision making context ($\lambda = 0.4$),

MPI is not a good choice ($VoI = 0$) and the optimal strategy is NA (Table 9).

It is also shown that depending on the specific maintenance decision making context, the VoI provided by an inspection method with a smaller mean detectable crack size (MPI) may be lower than the VoI provided by an inferior inspection method (VI). For example, when $\lambda = 0.4$ and $n = 1$, VoI (MPI) = 0 (Table 7) while VoI (VI) = 397.1 (Table 8). Thus, when $\lambda = 0.4$ and $n = 1$, VI is a better choice than MPI and the optimal strategy is CBM (VI), not CBM (MPI) (Table 9). This is because the VoI depends on information utilization in a specific decision making context, and the VoI is higher when the information can be better acted on. When $\lambda = 0.4$, it indicates that the costs of a maintenance intervention are high. Under such a decision context, less maintenance is desirable and repair of small cracks is not cost-beneficial. Under such a decision context, although MPI can detect smaller cracks than VI, it is not sensible to act on such detection information (i.e. repair of detected small cracks) and the detection information would not be utilized. Note this conclusion is subjected to the specific maintenance decision making context which is characterized by the value of λ . When the value of λ is different, the VoI s provided by both MPI and VI are different and the conclusion is different. However, this example shows that the information provided by an inspection method with higher crack detection capacity does not necessarily add more value to a specific maintenance decision making problem. Hence, this study highlights the importance of performing VoI computation and accordingly selecting an appropriate inspection method that adds value in a specific maintenance decision making context before carrying out inspections and adopting CBM.

7 CONCLUSIONS

We have addressed the structural integrity management problem in marine and offshore engineering by developing a Bayesian decision optimization (BDO) approach to optimal maintenance planning under uncertainty. The approach explicitly models uncertainties that affect maintenance decision making, stochastics of crack growth, maintenance effects and crack detection capacities of inspection methods. Also, the approach considers all available maintenance strategies with and without condition inspections in searching for an optimal maintenance strategy, by which the value of information (VoI) provided by future inspections is computed. The approach has been tested under different maintenance decision

making contexts (which is characterized by the cost ratio of maintenance to failure), different inspection methods, and different number of maintenance interventions. The results show that the BDO approach can result in optimal maintenance strategies reliably and is applicable to a wide range of maintenance decision making problems.

It has been shown that VoI computation is important and necessary before adopting condition-based maintenance (CBM). It has been found the VoI is equal to zero in various maintenance decision making contexts. For example, when the costs of maintenance are very low (compared with the costs of failure), the VoI provided by an inspection method with low crack detection capability (e.g. VI) may be zero. When the costs of maintenance are high, the VoI provided by an inspection method with high crack detection capability (e.g. MPI) may be zero. When multiple inspections are considered, the VoI provided by some of the inspections may be zero.

When the VoI is equal to zero, CBM is not the optimal strategy and the optimal maintenance strategy derived by the BDO approach is the prior optimal strategy based on prior crack information (without involving inspections). When the VoI is larger than zero, the optimal maintenance strategy obtained by the BDO approach is CBM. Thus, the BDO approach is reliable in resulting in optimal strategies in various maintenance decision making problems while the CBM is not optimal in the maintenance decision making problems where VoI is equal to zero. The advantage of the BDO approach is attributed to the fact that by the approach both prior crack prediction information and additional crack information (e.g. inspection results) are utilized in decision-making process while by adopting the CBM, maintenance decisions are directly based on inspection results.

The proposed approach can be used to support rational maintenance planning under uncertainty. This study has demonstrated potentials of applying the proposed approach to various maintenance decision making problems and contexts, which essentially can be modelled and solved within the framework of the proposed approach. Firstly, the approach can take all available maintenance decisions or strategies in account, which include the strategies relying on inspection or monitoring information (e.g. detection or condition based maintenance, preventive maintenance), as well as strategies without involving inspections (e.g. time or age based maintenance). Secondly, by VoI computation, it is possible to determine whether to adopt inspections and CBM or

not. If the VoI is large than zero, then inspections and CBM are recommended. If the VoI is equal to zero, then CBM is not cost-beneficial and the maintenance strategy obtained by prior decision optimization is the optimal one. Lastly, utility increment is a metric for evaluation of the available maintenance strategies, and can be represented by any metric specifically defined by a maintenance policy-maker, e.g. revenue increments, cost reductions, etc.

In the study, it is considered that the costs of both inspections (c_{i0}), i.e. MPI and VI, are much lower than the costs of a maintenance intervention (c_{m0}). This is reasonable for most structural components. Thus, the costs between MPI and VI are assumed to be the same. In fact, the costs of MPI are higher than VI. However, the influence of this difference on LCC are marginal, compared with high costs of maintenance interventions and failure. If this difference was considered, the VoI by MPI (in Tables 7 and 10) would be slightly lower. Then it would be more likely the VoI provided by MPI is lower than the VoI provided by VI in some maintenance decision making contexts.

There are other parameters that influence derivation of an optimal maintenance strategy under uncertainty. For example, the effects of a maintenance strategy can be influenced by intervention timings. In this study, the timings are obtained based on periodic maintenance intervention policy, which is widely adopted in the literature, because periodic interventions are more easy to be implemented from a management perspective^{27, 28, 34}. Also, the input parameters of the probabilistic crack growth model in Section 2 can affect the results of optimal maintenance decision making. The values of these parameters are inputs of this study and represent existing or prior knowledge about the fatigue crack growth phenomenon.

ACKNOWLEDGEMENTS

The authors would like to express their gratitude to the European Union's Horizon 2020 research and innovation programme for their funding towards this project under the Marie Skłodowska-Curie grant agreement No. 642453 (<http://trussitn.eu>).

REFERENCES

1. Besnard F, Bertling L. An approach for condition-based maintenance optimization applied to wind turbine blades. *IEEE Transactions on Sustainable Energy*. 2010;1(2):77-83.
2. Niu G, Yang B-S, Pecht M. Development of an optimized condition-based maintenance system by data fusion and reliability-centered maintenance. *Reliability Engineering & System Safety*. 2010;95(7):786-796.
3. Zou G, Banisoleiman K, González A, Faber MH. Probabilistic investigations into the value of information: A comparison of condition-based and time-based maintenance strategies. *Ocean Engineering*. 2019;188:106181.
4. Verbert K, De Schutter B, Babuška R. Timely condition-based maintenance planning for multi-component systems. *Reliability Engineering & System Safety*. 2017;159:310-321.
5. Moan T. Life-cycle assessment of marine civil engineering structures. *Structure and Infrastructure Engineering*. 2011;7(1-2):11-32.
6. Frangopol DM, Soliman M. Life-cycle of structural systems: recent achievements and future directions. *Structure and infrastructure engineering*. 2016;12(1):1-20.
7. Shafiee M, Finkelstein M, Bénguer C. An opportunistic condition-based maintenance policy for offshore wind turbine blades subjected to degradation and environmental shocks. *Reliability Engineering & System Safety*. 2015;142:463-471.
8. Soliman M, Frangopol DM, Mondoro A. A probabilistic approach for optimizing inspection, monitoring, and maintenance actions against fatigue of critical ship details. *Structural Safety*. 2016;60:91-101.
9. Zou G, Banisoleiman K, González A. Reliability-based inspection planning in view of both crack initiation and propagation. CRC Press; 2017.
10. Lassen T, Recho N. Risk based inspection planning for fatigue damage in offshore steel structures. American Society of Mechanical Engineers; 2015:V003T02A076-V003T02A076.
11. Dong Y, Frangopol DM. Incorporation of risk and updating in inspection of fatigue-sensitive details of ship structures. *International Journal Of Fatigue*. 2016;82:676-688.
12. Ang A-S. Life-cycle considerations in risk-informed decisions for design of civil infrastructures. *Structure and Infrastructure Engineering*. 2011;7(1-2):3-9.
13. Lee S-y, Jo C, Bergan P, Pettersen B, Chang D. Life-cycle cost-based design procedure to determine the optimal environmental design load and target reliability in offshore installations. *Structural Safety*. 2016;59:96-107.
14. Nielsen JS, Sørensen JD. Methods for risk-based planning of O&M of wind turbines. *Energies*. 2014;7(10):6645-6664.
15. Grall A, Bénguer C, Dieulle L. A condition-based maintenance policy for stochastically deteriorating systems. *Reliability Engineering & System Safety*. 2002;76(2):167-180.
16. Zonta D, Glisic B, Adriaenssens S. Value of information: impact of monitoring on decision making. *Structural Control and Health Monitoring*. 2014;21(7):1043-1056.
17. Pozzi M, Der Kiureghian A. Assessing the value of information for long-term structural health

- monitoring. *International Society for Optics and Photonics*; 2011:79842W.
18. Thöns S, Schneider R, Faber MH. Quantification of the value of structural health monitoring information for fatigue deteriorating structural systems. 2015:
19. Irman AA, Thöns S, Leira BJ. Value of information-based inspection planning for offshore structures. *American Society of Mechanical Engineers*; 2017:
20. Haladuick S, Dann MR. Value of information-based decision analysis of the optimal next inspection type for deteriorating structural systems. *Structure and Infrastructure Engineering*. 2018:1-10.
21. Konakli K, Sudret B, Faber MH. Numerical investigations into the value of information in lifecycle analysis of structural systems. *ASCE-ASME Journal of Risk and Uncertainty in Engineering Systems, Part A: Civil Engineering*. 2015;2(3):B4015007.
22. Ahmad R, Kamaruddin S. An overview of time-based and condition-based maintenance in industrial application. *Computers & Industrial Engineering*. 2012;63(1):135-149.
23. Lotsberg I, Sigurdsson G, Fjeldstad A, Moan T. Probabilistic methods for planning of inspection for fatigue cracks in offshore structures. *Marine Structures*. 2016;46:167-192. doi:10.1016/j.marstruc.2016.02.002
24. DNV G. DNVGL-RP-0005: Fatigue design of offshore steel structures. Det Norske Veritas AS, Oslo, Norway; 2014.
25. Paris P, Erdogan F. A critical analysis of crack propagation laws. *Journal of basic engineering*. 1963;85(4):528-533.
26. Ayala-Uraga E, Moan T. Fatigue reliability-based assessment of welded joints applying consistent fracture mechanics formulations. *International Journal of Fatigue*. 2007;29(3):444-456. doi:10.1016/j.ijfatigue.2006.05.010
27. Zio E, Compare M. Evaluating maintenance policies by quantitative modeling and analysis. *Reliability Engineering & System Safety*. 2013;109:53-65.
28. Huynh KT, Grall A, Bérenguer C. Assessment of diagnostic and prognostic condition indices for efficient and robust maintenance decision-making of systems subject to stress corrosion cracking. *Reliability Engineering & System Safety*. 2017;159:237-254.
29. Zitrou A, Bedford T, Daneshkhah A. Robustness of maintenance decisions: Uncertainty modelling and value of information. *Reliability Engineering & System Safety*. 2013;120:60-71.
30. Garbatov Y, Soares CG. Cost and reliability based strategies for fatigue maintenance planning of floating structures. *Reliability Engineering & System Safety*. 2001;73(3):293-301.
31. Madsen H, Torhaug R, Cramer E. Probability-based cost benefit analysis of fatigue design, inspection and maintenance. 1991:18-19.
32. Ditlevsen O, Madsen HO. *Structural reliability methods*. vol 178. Wiley New York; 1996.
33. Faber MH. *Statistics and probability theory: in pursuit of engineering decision support*. vol 18. Springer Science & Business Media; 2012.
34. Tolentino D, Ruiz SE. Influence of structural deterioration over time on the optimal time interval for inspection and maintenance of structures. *Engineering Structures*. 2014;61:22-30.