



Title	Operational security at high penetrations of stochastic, non-synchronous generation
Authors(s)	Daly, Pádraig, Power, Michael, Keane, Andrew, Flynn, Damian
Publication date	2013-09-05
Publication information	Daly, Pádraig, Michael Power, Andrew Keane, and Damian Flynn. "Operational Security at High Penetrations of Stochastic, Non-Synchronous Generation." IEEE, September 5, 2013. https://doi.org/10.1109/upec.2013.6714960 .
Conference details	2013 48th International Universities' Power Engineering Conference (UPEC), DIT, Ireland, 2-5 September 2013
Publisher	IEEE
Item record/more information	http://hdl.handle.net/10197/8029
Publisher's statement	© 2013 IEEE. Personal use of this material is permitted. Permission from IEEE must be obtained for all other uses, in any current or future media, including reprinting/republishing this material for advertising or promotional purposes, creating new collective works, for resale or redistribution to servers or lists, or reuse of any copyrighted component of this work in other works.
Publisher's version (DOI)	10.1109/upec.2013.6714960

Downloaded 2026-05-01 23:47:26

The UCD community has made this article openly available. Please share how this access benefits you. Your story matters! (@ucd_oa)



© Some rights reserved. For more information

Operational Security at High Penetrations of Stochastic, Non-Synchronous Generation

Pádraig Daly, Michael Power, Andrew Keane and Damian Flynn
School of Electrical, Electronic and Communications Engineering
University College Dublin, Ireland

Abstract—As levels of stochastic, non-synchronous renewable generation (wind, wave and solar) significantly increase, system operators are faced with many new operational challenges. Consequently, there is a growing need to create flexible operational strategies based on near-real-time system assessment. This paper presents an outline of the operational challenges arising from stochastic, non-synchronous generation, as well as the tools which can be used to cost-effectively enhance operational security.

Index Terms—Security-constrained optimal power flow, security-constrained unit commitment, wind power generation.

I. INTRODUCTION

WITH a significant shift towards the utilisation of both sustainable and indigenous sources of power generation, system operators (SOs) have been tasked with securely integrating large amounts of variable renewable generation [1]–[3]. Such a trend is fundamentally altering the character of electric power systems, with many new operational challenges arising, due to both the non-synchronous and stochastic nature of wind, wave and solar generation. The utilisation of online dynamic security assessment (DSA) tools to enhance operational decision making capability seems prudent, as with stochastic generation, net load variability and uncertainty, over multiple timescales, increases significantly [4]. Coupled with concerns that power system integrity may be compromised at high non-synchronous penetrations [5], it is evident that new operational strategies and rules are needed. The primary goal of such strategies is to maximise operational security, over multiple timeframes and scenarios, so that systems are robust to changing operating conditions. Such an objective can be achieved by considering future operational system states through utilising tools such as stochastic, DC security-constrained unit commitment (SSCUC) and AC security-constrained optimal power flow (SCOPF).

II. OPERATIONAL CHALLENGES ARISING FROM NON-SYNCHRONOUS GENERATION

Many of the ancillary services required for secure power system operation are not inherently provided by non-

This work was conducted in the Electricity Research Centre, University College Dublin, Ireland, which is supported by the Commission for Energy Regulation, Bord Gáis Energy, Bord na Móna Energy, Cylon Controls, EirGrid, Electric Ireland, Energia, EPRI, ESB International, ESB Networks, Gaelectric, Intel, SSE Renewables, and UTRC. This publication has emanated from research conducted with the financial support of the Irish Research Council's Embark Initiative.

synchronous generation. Operational issues resulting from the depletion of such system services are discussed below.

A. Synchronous Inertia and Electromagnetic Torque

Non-synchronous generation and high voltage direct current (HVDC) interconnection are decoupled from the system frequency and consequently do not provide an inertial response to a system active power imbalance. Lower levels of system synchronous inertia imply a higher rate of change of frequency (ROCOF) following a contingency, which could threaten short-term frequency stability [6]. There are also implications for the system frequency nadir following a contingency, as with higher ROCOFs, a faster system frequency response is required to correct a frequency excursion, which is not guaranteed if higher non-synchronous penetrations reduce the number of frequency-governing units online.

As more conventional generation is displaced by non-synchronous generation, the angular separation between online conventional units increases, which in turn increases the likelihood of non-oscillatory (first-swing) rotor angle instability. There is also a potential reduction in the number of power system stabilisers (PSSs), used to enhance the system damping torque, which determines how quickly electromechanical oscillation modes are damped out. Lower system damping torque implies an increase in the likelihood of oscillatory rotor angle instability. Care should be taken to ensure that PSS-enabled units, that are appropriately located in the network, stay online.

B. Steady-State and Dynamic Reactive Power

As the proportion of distribution-connected non-synchronous generation grows, steady-state voltage control can become more difficult due to such generation's non-participation in voltage regulation. Transmission-connected non-synchronous generation is normally mandated to provide terminal voltage control, however due to differing machine properties, it typically does not provide the same reactive power capability as conventional synchronous generation [7], particularly at low active power outputs. With non-synchronous distributed generation (wind and solar) changing both the nature and location of steady-state reactive power sources and sinks, there may be a need to develop operational strategies which utilise controllable non-synchronous reactive power sources so as to improve voltage security. Intuitively, the geographical diversity of stochastic, non-synchronous

generation could aid system voltage control, as reactive power sources need to be electrically dispersed to complement system demand. However, given the uncertainty associated with both the number of stochastic, non-synchronous generators online, and their output, quantifying their aggregate reactive power capability may be difficult.

The reduction in both system synchronising and damping torque can be mitigated by increased provision of dynamic reactive power during disturbances. However, this functionality has traditionally been provided by the fast excitation response of conventional units (automatic voltage regulation). Any potential reduction in dynamic reactive power provision from conventional units during contingencies can be mitigated by utilising the voltage control capability of transmission-connected non-synchronous generation [8], as when their reactive power is controlled, more direct support is provided to the synchronous units online.

III. OPERATIONAL CHALLENGES ARISING FROM STOCHASTIC GENERATION

With the integration of stochastic generation, net load variability has increased, in turn increasing the ramping burden placed on conventional generation and leading SOs to quantify the flexible resource capacity at their disposal (start-up/shutdown times, ramp rates, minimum generation levels) [9]. Indeed, in the (near) future, conventional generation's role may transition from the provision of energy to the provision of flexibility services such as frequency regulation, replacement reserve and up/down ramping reserve, so as to guard against high net load ramps. However, accelerated fatigue (particularly units which were traditionally base-loaded) due to cycling (increased start-ups and ramping) must be recognised. Net load uncertainty is also increased with increasing penetrations of stochastic generation, as such forecasts can be relatively inaccurate (e.g. 10% forecasting errors for wind production in the day-ahead timeframe, increasing further as the time horizon extends). Strategies are needed so that forecast errors do not significantly increase the cost of system operation, arising from both increased conventional unit start-ups and additional reserve being carried.

It is not only conventional generation that will be forced to operate over a wider range during times of high stochastic penetration; the network itself will be subjected to significant variability, with the predictability of both power flow magnitudes and directions decreasing due to an increase in the variability and uncertainty of power injections. It is evident that the timing of stress situations will become less certain. Bus voltage variability will also increase, with instances of voltage rise now occurring on distribution feeders due to active power injections from distributed generation [10], coupled with the distribution network's inherently low X/R ratio. High active power injections from distributed generation also lower transmission system voltages due to the increased reactive demand at the distribution level. The locations of such problems are also highly variable, with the distribution of wind and

solar power varying significantly as weather fronts 'traverse' a power system over time.

IV. OPERATIONAL TOOLS TO ENHANCE FLEXIBILITY

A. Ramping Timeframe (minutes to hours)

Unit commitment (UC) schedules, which are robust to multiple forecasts, may be required to ensure operational security and flexibility in the ramping timeframe (minutes to hours). Such an objective can be achieved through the utilisation of stochastic, security-constrained unit commitment (SSCUC). Stochastic UC utilises Monte Carlo simulations to produce a scenario tree for possible forecasts of wind, wave and solar generation production, generator forced outages and/or demand for each interval of a given time horizon. An alternative option to stochastic UC is to utilise a deterministic approach and quantify the reserve required to meet the increase in net load variability and uncertainty. However, reserve requirements based on forecasting errors may not effectively cover uncertainty as stochastic penetrations significantly increase, noting that up/down ramping reserve is needed to cover net load issues. Security-constrained unit commitment (SCUC) schedules are produced by applying thermal network constraints for both pre- and post-contingency states. Typically, in order to increase computational efficiency, DC power flow models are used in SCUC. As network congestion may limit the ability of a system to deploy its resources to meet net load variability, as well as increase the curtailment of stochastic generation, which can be seen as a flexibility sink, inclusion of the network in the UC formulation is particularly relevant when attempting to increase operational flexibility. Constraints arising from voltage considerations (must-run units in a particular network location for voltage support) may also be considered.

B. Steady-State Timeframe (seconds to minutes)

Security-constrained optimal power flow (SCOPF) can be used to enhance operational flexibility in the steady-state timeframe (seconds to minutes) by considering not only the current operational state, but also future possible states. For a given set of contingencies and an initial operating point, SCOPF ensures that system operating limits and equipment ratings are not violated in pre- or post-contingency states, while optimally dispatching generating units [11]. SCOPF produces updated setpoints for real and reactive outputs of generating units and HVDC links, transformer tap positions, shunt reactor/capacitor switching states, static var compensator state, etc. A fundamental part of SCOPF's contribution to operational flexibility is the contingency analysis. N-1 contingency analysis is an industry standard, however a limitation of this methodology is that it applies an equal weight to all contingencies considered. Probabilistic contingency analysis may be required as stochastic penetrations increase, as due to time constraints, it may no longer be practical to analyse all contingencies. Filtering mechanisms may also be needed, so that the computational burden does not impinge on the security analysis.

Preventive security control is the traditional SCOPF approach, and aims to prepare the system in the normal state so that it can withstand future (uncertain) contingencies without violating any system limits. However, manoeuvring a system into a cost effective N-1 secure configuration may no longer be possible with high stochastic, non-synchronous penetrations, with the timing and causes of stress situations increasingly difficult to predict. With current N-1 security practice not accounting for uncertainty, extending this methodology to probabilistic decisions, with a given confidence band, may be prudent. An alternative to a probabilistic approach is the implementation of a corrective control strategy (remedial action scheme), as perhaps the additional security/robustness provided by preventive action is not necessarily worth the cost incurred for low probability events. Corrective security control aims to bring the system back to the normal state following a contingency which has caused security concerns. However, it must be noted that there may be a risk incurred in taking control action(s) in the post-contingency state due to time constraints. It is also difficult to represent the consequences of corrective actions failing to stabilise the post-contingency state as a cost function within the SCOPF. With the need to balance operational security and economy, a mixture of probabilistic preventive actions and corrective actions may be considered optimal. By also integrating SCOPF with SSCUC, so that the SSCUC schedule is reviewed when security constraints are not satisfied in SCOPF, is also advisable. A possible outline of an integrated SSCUC-SCOPF tool is shown in Fig. 1.

V. DYNAMIC SECURITY ASSESSMENT

With a ‘stressed’ network exhibiting significantly different dynamic behaviour to that of a ‘non-stressed’ system, consideration of short-term stability within steady-state analysis may be necessary. Thus, a representation of system dynamic behaviour in the SCOPF formulation may be required so that short- and long-term system security is maintained. One approach is to include the results of transient stability analysis as constraints in the SCOPF [12]. To adhere with the goal of near-real-time security assessment, a ‘light’ representation of stability issues is desired. So as to be appropriate for operational analysis, a margin to instability, be it frequency (inertial constraints), voltage (loadability margin), or transient stability (critical clearing times) could be included. Security margins are an important output of dynamic security assessment (DSA) as they inform SOs of:

- 1) the current operational state,
- 2) how close the system is to stability limits, and
- 3) the mechanisms that may drive the system towards reduced security.

It is also appropriate that stability limits are expressed in terms of controllable variables, such as generator power output, as otherwise a stability margin has limited practicality for SOs.

VI. METHODOLOGY

A modified version of the IEEE 48-bus reliability test system (RTS), consisting of two 24-bus networks interconnected

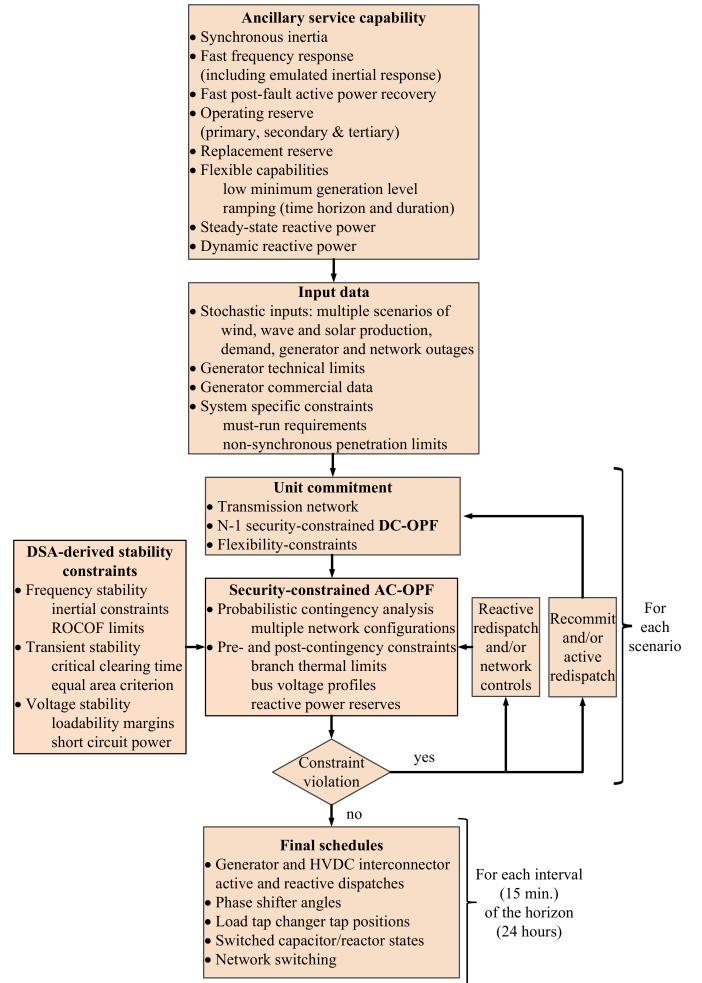

Fig. 1. Integration of SSCUC and SCOPF

via three tielines, is now considered. A single-line diagram of the test system is shown in Fig. 2. The network (bus, branch and load) data, as well as the generating unit technical characteristics, are defined in [13]. The annual system demand is 30.7 TWh, with a peak of 5.7 GW. Installed conventional generation capacity is 6.8 GW. 17 wind farms are added, all located in Area 1, with the wind farm capacity set inversely proportional to the bus load, replicating wind generation’s typically remote location from system demand. In order to capture the underlying correlation between wind farm output and location, each wind farm’s production level is based on Irish wind farms which have a similar geographical displacement to those in the modified 48-bus IEEE RTS. Wind generation is assumed to meet 15% of the annual electricity demand, with an installed capacity of 1.7 GW.

The PLEXOS modelling tool [14] and FICO Xpress 7.5 mixed integer programming solver [15] are used to conduct daily UC and economic dispatch (ED) at an hourly resolution. Four contingency reserve categories (full delivery within 5, 15, 90 and 300 seconds respectively) are specified from the largest infeed or inter-area tieline flow. The minimum

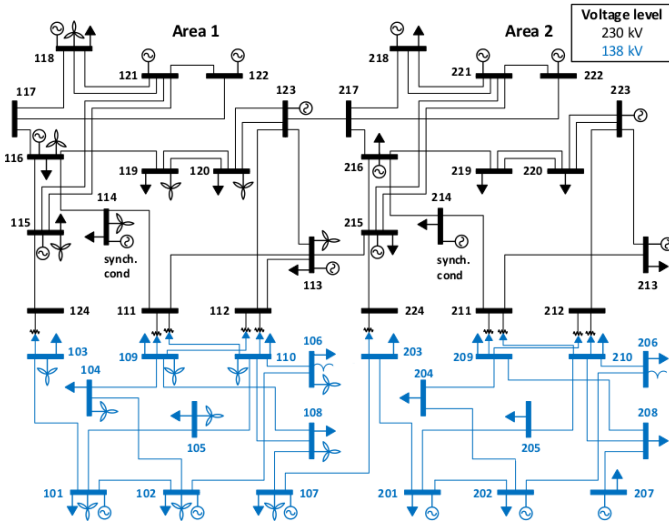

Fig. 2. Single line diagram of modified version of 48-bus IEEE RTS

requirement criteria for up/down ramping reserve (spinning and non-spinning) is the 99th percentile of net load ramps over both 1 and 4 hour timeframes. Both generator forced and scheduled outages are considered.

In order to analyse the steady-state and dynamic security of the test system, the PSS/E SCOPF and dynamic tools [16] are used. Excluding generator islanding, all single-line outages are considered in the DC (within SCUC) and AC (within SCOPF) N-1 contingency analysis. In SCOPF, the system load is modelled as equally weighted ZIP components. With all wind farms transmission-connected, it is assumed that each wind farm is operating in a terminal voltage control mode, with a reactive power capability of ± 0.95 times the active power output. To balance cost with security, the SCUC minimises total system operational costs, whereas the SCOPF minimises control adjustments (generator active power redispatch, transformer tap position change).

The dynamic data for each synchronous machine is based on similarly sized (MVA rating) generating units of the same technology in the Irish system. 66 synchronous machines are modelled, with a range of excitation systems and turbine-governors used. Selected units are equipped with PSSs. The wind turbine generator model used is a generic model of the 1.5 MW GE doubly-fed induction generator.

VII. RESULTS

A. Security-Constrained Unit Commitment

Year long UC and ED are conducted. The UC and ED schedule produced for a typical peak demand hour in winter (5 GW) is selected to analyse the impact of DC N-1 security constraints within UC. Fig. 3 shows the differences in bus net active power injections (generation minus load) for the schedules produced by UC (no N-1 security constraints) and SCUC for this typical peak demand hour. It can be seen that considering the loss of each branch of the network in the UC formulation has an impact on the active power output level

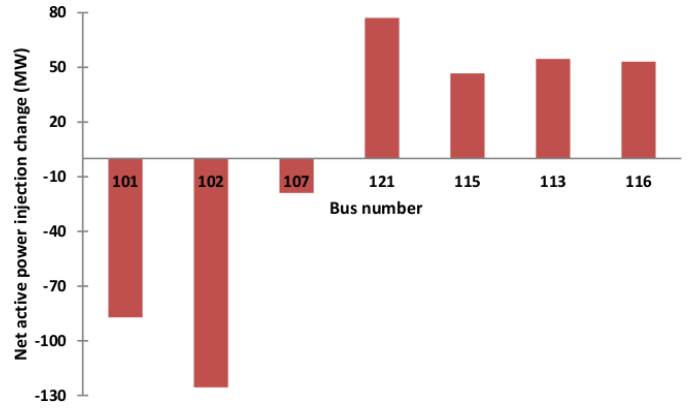

Fig. 3. Changes in net active power injections (generation minus load) due to N-1 security constraints within unit commitment

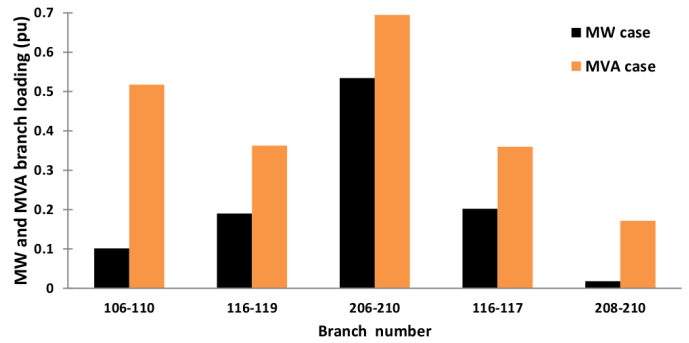

Fig. 4. Impact of considering reactive power on branch flows

of generating units. Using active power flow as a thermal overload metric may not be prudent however, as there could be considerable reactive power flows throughout the network, as seen in Fig. 4, which considers the following cases:

- 1) **MW case:** branch active power flows calculated by SCUC
- 2) **MVA case:** branch active and reactive power flows calculated by power flow for the SCUC dispatch

The five largest deviations between the MW and MVA cases are shown, implying that DC N-1 security constraints may give an optimistic view of branch loading levels. Each branch flow is expressed in per unit on the respective branch's rating.

B. Security-Constrained Optimal Power Flow

In order to compare the robustness of the results produced using DC N-1 contingency analysis (within SCUC) and AC N-1 contingency analysis (within SCOPF), two cases are considered, both for the SCUC schedule produced for the hour of highest instantaneous wind penetration (50%).

- 1) **Base case:** branch active power constraints to mitigate thermal overloads, as calculated by SCUC
- 2) **SCOPF case:** branch active power, branch reactive power, and bus voltage constraints to mitigate thermal overloads and bus voltage violations, as calculated by SCOPF

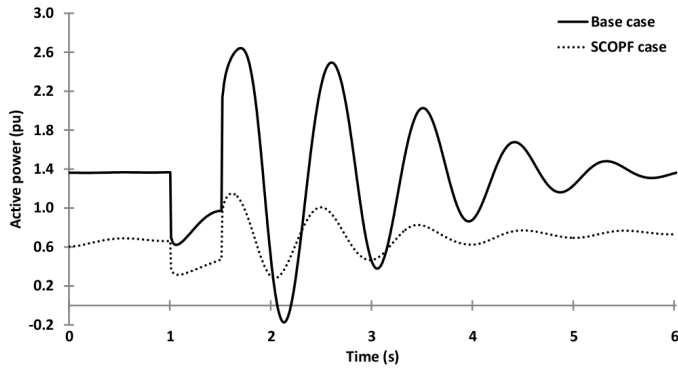

Fig. 5. Active power response of generator 216 to a three-phase fault at bus 217 for the base case (DC N-1 security constraints) and the SCOPF case (AC N-1 security constraints)

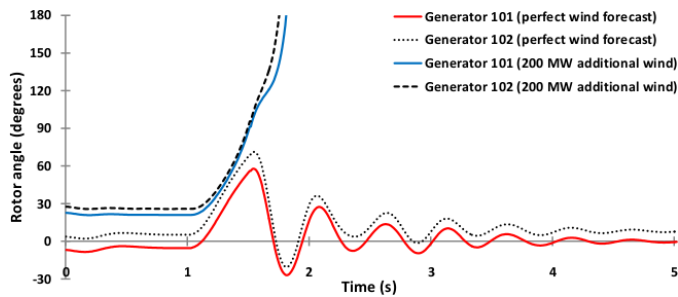

Fig. 6. Rotor angle response of generators 101 and 102 to a three-phase fault at bus 105 for the perfect wind forecast case and the additional 200 MW wind case

For both the base and SCOPF cases, the active power response of generator 216 to a three-phase fault, applied to bus 217 (load bus) for 500 ms, is analysed, and is illustrated in Fig. 5. The difference in the initial active power output of generator 216 between the base case and SCOPF case is due to the setpoint changes made by SCOPF for thermal and voltage considerations. It can be seen that this change in the pre-contingency active power output of generator 216 has an impact on its post-fault active power response, implying that there may be a need to represent system dynamic behaviour in the SCOPF formulation, so that both transient and steady-state system security is considered.

C. Forecast Uncertainty

In order to analyse the value of considering future operational states, two different wind scenarios are considered:

- 1) **perfect forecast case:** the realised wind production is perfectly forecasted
- 2) **additional 200 MW wind case:** there is a 200 MW increase in wind production from that forecasted

The SCUC dispatch produced for the hour following the typical evening peak used in Section VII-A, is selected. The 200 MW wind ramp, of one hour duration, increases the wind penetration from 22% to 34% and causes two of the marginal units (three oil-fired units at bus 107) to be decommitted, with the remaining unit dispatched down to its minimum generation

level. So as to determine the possible consequences of this wind ramp on operational security, a three-phase fault, applied to bus 105 (load bus) for 500 ms, is considered. The rotor angle response of generators 101 and 102 are shown in Fig. 6. It can be seen that without the voltage support and synchronising torque provided by the units at bus 107, units 101 and 102 lose synchronism with the system.

VIII. CONCLUSION

The use of operational tools such as stochastic, security-constrained unit commitment (SSCUC) and security-constrained optimal power flow (SCOPF) may become more prevalent as penetrations of wind, wave and solar generation increase. For computational efficiency, DC N-1 security constraints can be implemented within unit commitment, however, there can be differences between the branch flows calculated by DC and AC tools.

When active power redispaches are recommended by SCOPF and/or SSCUC, the impact of such action on the dynamic behaviour of the system may have to be analysed. The financial implications of active power redispach for security reasons, in a market environment, may also have to be considered. Utilising reactive optimisation to enhance operational security, if the same level of security can be achieved, may be beneficial. The value of considering future operational states to mitigate wind forecast uncertainty, through stochastic optimisation, also requires study.

REFERENCES

- [1] California ISO, "Operational requirements and generation fleet capability at 20% RPS," Aug. 2010.
- [2] EirGrid and SONI, "Ensuring a secure, reliable and efficient power system in a changing environment," June 2011.
- [3] Australian Energy Market Operator, "Wind integration in electricity grids: international practice and experience," Oct. 2011.
- [4] H. Holttinen, J. Kiviluoma, A. Estanqueiro, E. Gomez-Lazaro, B. Rawn, J. Dobschinski, P. Meibom, E. Lannoye, T. Aigner, Y. Hwei Wan, and M. Milligan, "Variability of load and net load in case of large scale distributed wind power," in *10th International Workshop on Large-scale Integration of Wind Power into Power Systems*, Aarhus, Denmark, 2011.
- [5] EirGrid and SONI, "All island TSO facilitation of renewables studies," June 2010.
- [6] L. Rutledge, N. Miller, J. O'Sullivan, and D. Flynn, "Frequency response of power systems with variable speed wind turbines," *IEEE Trans. Sustain. Energy*, vol. 3, no. 4, pp. 683–691, Oct. 2012.
- [7] S. Engelhardt, I. Erlich, C. Feltes, J. Kretschmann, and F. Shewarega, "Reactive power capability of wind turbines based on doubly fed induction generators," *IEEE Trans. Energy Conversion*, vol. 26, no. 1, pp. 364–372, 2011.
- [8] E. Vittal, A. Keane, and M. O'Malley, "Rotor angle stability with high penetrations of wind generation," *IEEE Trans. Power Syst.*, vol. 27, no. 1, pp. 353–362, 2012.
- [9] RWE, "The need for smart megawatts," Dec. 2009.
- [10] A. Keane and M. O'Malley, "Optimal allocation of embedded generation on distribution networks," *IEEE Trans. Power Syst.*, vol. 20, no. 3, pp. 1640–1646, 2007.
- [11] F. Capitanescu, J. Martinez Ramos, P. Panciatici, D. Kirschen, A. Marano Marcolini, L. Platbrood, and L. Wehenkel, "State-of-the-art, challenges, and future trends in security constrained optimal power flow," *Electric Power Systems Research*, vol. 81, no. 8, pp. 1731–1741, 2011.
- [12] R. Zarate-Minano, T. Van Cutsem, F. Milano, and A. Conejo, "Securing transient stability using time-domain simulations within an optimal power flow," *IEEE Trans. Power Syst.*, vol. 25, no. 1, pp. 243–253, 2010.

- [13] Reliability Test System Task Force, "The IEEE reliability test system - 1996," *IEEE Trans. Power Syst.*, vol. 14, no. 3, pp. 1010–1020, 1999.
- [14] PLEXOS for power systems. [Online]. Available: www.energyexemplar.com
- [15] FICO Xpress Optimization Suite. [Online]. Available: www.fico.com
- [16] PSS/E 33. Siemens Power Technologies International. [Online]. Available: www.energy.siemens.com