



Title	Probabilistic investigations into the value of information: A comparison of condition-based and time-based maintenance strategies
Authors(s)	Zou, Guang, Banisoleiman, Kian, González, Arturo, Faber, Michael Havbro
Publication date	2019-09-15
Publication information	Zou, Guang, Kian Banisoleiman, Arturo González, and Michael Havbro Faber. "Probabilistic Investigations into the Value of Information: A Comparison of Condition-Based and Time-Based Maintenance Strategies." Elsevier BV, September 15, 2019. https://doi.org/10.1016/j.oceaneng.2019.106181 .
Publisher	Elsevier BV
Item record/more information	http://hdl.handle.net/10197/10980
Publisher's statement	This is the author's version of a work that was accepted for publication in Ocean Engineering. Changes resulting from the publishing process, such as peer review, editing, corrections, structural formatting, and other quality control mechanisms may not be reflected in this document. Changes may have been made to this work since it was submitted for publication. A definitive version was subsequently published in Ocean Engineering (188, (2019)) https://doi.org/10.1016/j.oceaneng.2019.106181
Publisher's version (DOI)	10.1016/j.oceaneng.2019.106181

Downloaded 2026-05-02 01:16:16

The UCD community has made this article openly available. Please share how this access benefits you. Your story matters! (@ucd_oa)



© Some rights reserved. For more information

Probabilistic investigations into the value of information: a comparison of condition-based and time-based maintenance strategies

Guang Zou^{1,2}; Kian Banisoleiman¹; Arturo González²; Michael H. Faber³

¹Lloyd's Register Global Technology Center, Lloyd's Register Group Limited, Southampton, UK

²School of Civil Engineering, University College Dublin, Dublin, Ireland

³Department of Civil Engineering, Aalborg University, Aalborg, Denmark

Keywords: Integrity management; maintenance planning; probabilistic approach; reliability-based optimization; value of information; life cycle approach

Abstract

Optimal maintenance of marine structures is challenging due to numerous fatigue-prone components, serious failure consequences, high maintenance costs, harsh sea environments, difficult access, and uncertainties in fatigue loading, resistance, and inspection and maintenance activities. Time-based maintenance (TBM) is convenient to implement. However, condition-based maintenance (CBM) is proved to be more cost-effective. This paper assesses the value of information (VoI) by inspections in CBM, compared to TBM, and investigates the conditions for CBM to outperform TBM in terms of fatigue reliability. A probabilistic maintenance optimization method and a life cycle cost analysis framework are established to derive optimal CBM and TBM strategies with the objective of maximizing lifetime reliability and evaluating their life cycle costs. The advantages of CBM, in comparison to TBM, and the VoI depends strongly on the inspection time. The CBM can achieve higher reliability with fewer maintenance costs than the TBM. An illustrative example is provided using the established probabilistic method and framework to support optimal maintenance planning. This example serves as a basis to explain the benefits of CBM to lifetime fatigue reliability and cost reduction, the conditions when CBM is more beneficial than TBM, the conditions for beneficial, ineffective and unbeneficial repair, and the VoI by inspections.

1 Introduction

Fatigue and fracture are common deterioration phenomena across many industrial fields, e.g. marine structures, airplanes and nuclear plants, etc., and it is of paramount importance that strategies for

design, inspection and maintenance are targeted and optimized to ensure that the associated failure risks are managed efficiently and kept within acceptable limits. It is well known that even under a stress level much lower than material tensile strength, structural details can still fail if exposed to cyclic loading for a sufficient time, which defines fatigue life. Fatigue failure may initially be local, e.g., occurs in some stress concentration areas, especially in the vicinity of welds, however, failures of some critical details can lead to sudden rupture of the whole structural system and thus present huge risks to assets, human lives and the environment (Moan 2011). Welded details are especially prone to fatigue cracks due to welding flaws, material heterogeneity, and complicated local geometries, etc., which typically shorten fatigue life greatly (Fricke 2003). To mitigate the failure risks, fatigue life is assessed in the structural design stage to ensure that the designed fatigue life is longer than the required service life with a high confidence level. Depending on the application areas, several fatigue design approaches such as the well-known safe-life approach and damage-tolerate approach are available (Zerbst et al. 2014). Apart from the design stage, fatigue is a lifetime matter for structural management that needs continuous attention and measures, given that structural performance is in essence time-variant and subject to uncertainties associated with loading and material characteristics, geometries and modelling methods (Biondini and Frangopol 2016). Fatigue failure probability and risk assessed at the design stage need to be re-assessed and validated during operation due to several reasons, e.g. human errors in design and fabrication, discrepancies between design and as-built condition, changes of operational modes and loading conditions, and other hazards that were not foreseen or had not been taken into account at the design stage. Following re-assessment, maintenance actions may be needed to recover structural integrity and to improve reliability. The costs of maintenance are often justified by the huge loss associated with failure, not only financially, but also environmentally and socially (Moan 2011).

The benefits and costs of maintenance are dependent on maintenance strategies, such as inspection times and methods, repair criteria and repair methods, and these need to be optimized and planned well in advance to improve maintenance effectiveness, which is of great significance for structural systems with a substantial number of welded details, e.g. marine structures (Moan 2011, Soliman, Frangopol, and Mondoro 2016, Ventikos, Sotiralis, and Drakakis 2018). Traditionally maintenance activities have been reactive and corrective, in which a maintenance action is taken after a failure is observed. This can be rather risky depending on the failure consequences of a structural detail. To avoid significant failure consequences, preventive maintenance planning approaches have been developed, based on metrics such as service age (time), reliability, risk, damage condition, etc. Time-based maintenance (TBM) is a classical preventive maintenance approach and widely applied in engineering practices due to its simplicity in decision-making and implementation (Cullum et al. 2018).

Maintenance actions are scheduled at specific points in time to prevent significant failures during lifetime, and maintenance times and methods are optimized to reduce lifetime maintenance costs by time-variant reliability/risk analysis utilizing as-built and operational structural information (Temple and Collette 2015, Rinaldi et al. 2017, Wang et al. 2018)

Nowadays, condition-based maintenance (CBM) is gaining a wide range of attention as a result of developments in non-destructive (NDT) testing techniques, sensing and monitoring technology, system identification algorithms, and data science. Information on structural responses and damage conditions is collected during operations to assist rational maintenance decision-making. This information can be gathered via periodic inspections, which have been investigated for maintenance planning of general deteriorating systems (Yang, Zhao, and Ma 2018), ships (Ventikos, Sotiralis, and Drakakis 2018), marine machineries (Emovon, Norman, and Murphy 2016), process industry (Kallen and van Noortwijk 2005), etc. Although periodic inspections are simple to implement, they may not be as economically-efficient as non-periodic inspections. Similar to periodic inspections, non-periodic inspections have been applied to maintenance of general deteriorating structural systems (Zhao et al. 2010, Jiang 2010), ships (Guo et al. 2012, Dong and Frangopol 2016, Yang and Frangopol 2018), offshore assets and installations (Faber, Straub, and Goyet 2003, Faber et al. 2005, Straub and Faber 2006), etc. A more complete, yet costly, information collection approach, may be continuous health monitoring. Optimization frameworks for health monitoring strategies based on probabilistic analysis have been developed with applications in general structural systems (Zhou, Xi, and Lee 2007, Memarzadeh, Pozzi, and Kolter 2016), marine and offshore structures (Lu et al. 2018, Wang et al. 2018, Sabatino and Frangopol 2017), nuclear plants (Baraldi et al. 2011), railway networks (Verbert, De Schutter, and Babuška 2017), etc. In this paper, the information collection process by surveys, NDT and monitoring are referred to as inspection.

Despite the popularity of CBM, there are additional (direct and indirect) costs and efforts in relation to TBM, involving the collection of information, which can be substantial, especially for marine structures with a larger number of fatigue-prone details, difficult access and high loss as a result of interventions to normal operation. Questions remaining to be addressed are related to whether the costs associated with information collection in CBM are paid off by its benefits to risk reduction, i.e., “is the CBM a more beneficial maintenance strategy than the TBM for marine structures and under what conditions?”. While some theoretical algorithms for Value of Information (Vol) analysis have been proposed in civil and structural engineering (Sebastian 2018, Malings and Pozzi 2018, Konakli, Sudret, and Faber 2015), the concept has rarely been applied in the context of marine engineering. There is a lack of research on a direct comparison of CBM and TBM maintenance strategies, and on where the Vol

comes from, both of which are worthy topics for a marine engineering field currently dominated by TBM (Cullum et al. 2018). This paper aims to contribute to developing maintenance planning and Vol assessment for marine structures by comparative studies of TBM and CBM strategies, both of which are optimized for maximizing lifetime fatigue reliability taking probabilistic modelling of fatigue deterioration and expected maintenance costs into account. The remainder of this paper is structured as follows: Section 2 defines the fracture mechanics model employed for fatigue deterioration in terms of crack propagation, where the associated uncertainties are characterized probabilistically; Section 3 describes the maintenance strategies under investigation, a probabilistic maintenance optimization method for the maintenance strategies based on a reliability metric, and a lifetime cost analysis framework; Section 4 applies the maintenance optimization method and lifetime cost analysis framework to a typical fatigue-prone structural detail, that serves as example to illustrate and discuss the benefits of CBM and the Vol; and finally, Section 5 draws conclusions for maintenance planning of marine structures.

2 Probabilistic fatigue modelling

Fatigue analysis for marine structures is typically based on either the S-N approach or fracture mechanics (FM) approach. The S-N approach has been widely used in fatigue design, codes and regulations by virtue of its simplicity and solid experimental basis. The objective of a fatigue analysis based on the S-N approach is normally to ensure that the designed fatigue life is longer than a required service life with a relatively high confidence level. However, the S-N approach may not be suitable for providing a theoretical basis for maintenance planning, which requires taking details on crack dimensions into account. On the other hand, the FM approach addresses crack propagation explicitly. The fatigue process is understood as crack evolution and can be divided into three stages as shown by Figure 1: crack initiation, crack propagation and final fracture, where the vertical axis labelled a denotes crack size and the horizontal axis N represents the number of cycles. N_i is the number of cycles required for the crack propagation stage to start, and N_F is the number of cycles until the final fracture or fatigue life. Although the exact mechanism for crack initiation is still controversial, it is widely acknowledged that it relates largely to the mechanical behaviour of the material in the scale of grain size and to surface treatment techniques (Zerbst et al. 2014). The crack size in the crack initiation stage may not be critical for structural safety, as it is typically rather small and is hardly detectable by common NDT methods. In practice, the time spent by the crack in the crack initiation stage is often negligible compared with the crack propagation stage due to the presence of initial flaws/cracks introduced by the welding process. Also, the final fracture usually occurs very quickly, and the crack propagation stage thus is the focus of structural integrity

management in terms of maintenance intervention.

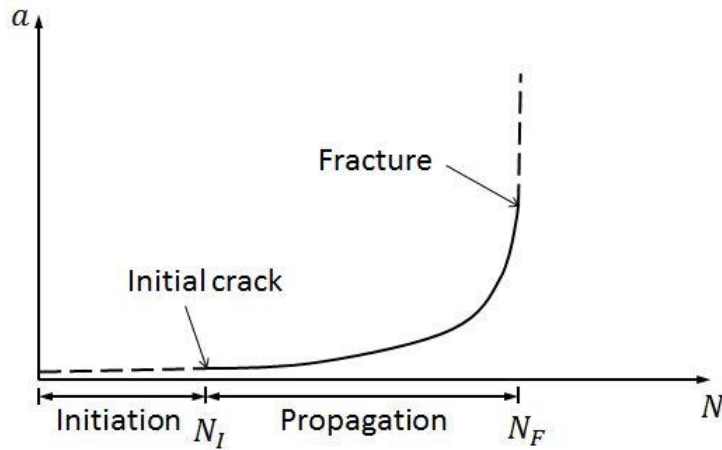

Figure 1. Three stages of crack development

2.1 FM approach

FM approach is employed herein since it provides a means of modelling the crack propagation explicitly and thus allows for reliability updating based on observations of crack growth. Equation (1) is Paris' law (Paris and Erdogan 1963), which correlates the crack propagation rate with the range of stress intensity factor for one-dimensional crack propagation.

$$\frac{da}{dN} = C\Delta K^m, \quad \Delta K_{th} \leq \Delta K \leq K_{mat} \quad (1)$$

where da/dN is crack propagation rate; C and m are material parameters; K_{mat} is material fracture toughness; ΔK is stress intensity factor range, and; ΔK_{th} is the threshold value for the stress intensity factor range. Figure 2 illustrates Equation (1) using a logarithmic scale.

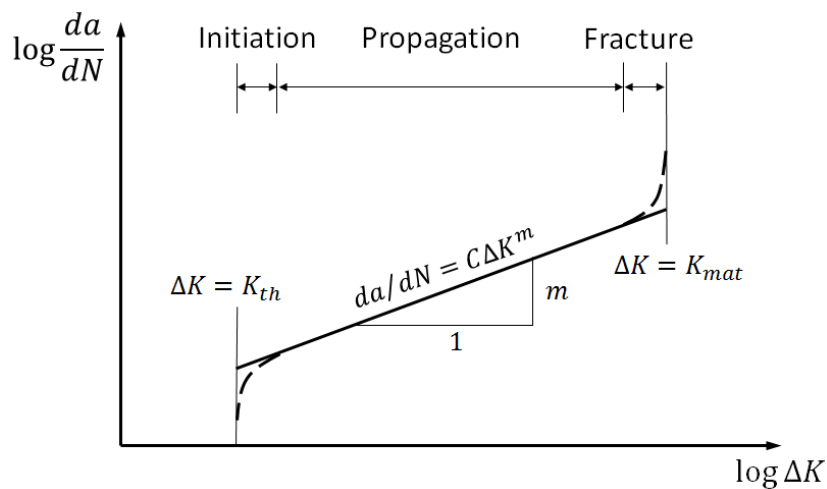

Figure 2. Stress intensity factor range

A typical stress intensity factor range ΔK in the crack propagation period can be derived using Equation (2) for one-dimensional crack propagation.

$$\Delta K = \Delta\sigma Y(a)\sqrt{\pi a} \quad (2)$$

where $Y(a)$ is a geometry function and $\Delta\sigma$ is stress range.

The allowed stress range $\Delta\sigma$ can be established by an S-N design curve such as Equation (3).

$$\begin{cases} N_F \Delta\sigma^{m_1} = \bar{a}_1 & N_F \leq 10^7 \\ N_F \Delta\sigma^{m_2} = \bar{a}_2 & N_F \geq 10^7 \end{cases} \quad (3)$$

where N_F is the fatigue life, m_1 and m_2 are fatigue strength exponents, and \bar{a}_1 and \bar{a}_2 are fatigue strength coefficients. The fatigue strength exponents and coefficients are obtained from a statistical analysis of specimen fatigue strength test data.

By integration of Equation (1), the number of cycles for the crack to develop from an initial crack size a_0 to the critical size a_c , i.e., the crack propagation life N_p , can be obtained via Equation (4). Depending on the initial crack size, the crack propagation life N_p may be shorter than the fatigue life N_F .

$$N_p = \frac{1}{\pi^{m/2} C \Delta\sigma^m} \int_{a_0}^{a_c} \frac{da}{a^{m/2} Y(a)^m} \quad (4)$$

If the geometry function $Y(a)$ was known, it is also possible to obtain the crack size $a(t)$ at time t when the structural detail has been exposed to $N(t)$ cycles of fatigue loading.

2.2 Uncertainty modelling

Given that the FM approach builds upon the physics of crack propagation for fatigue deterioration modelling, being somewhat more sophisticated than the S-N approach, it is important to consider various sources of uncertainties surrounding FM. Main sources of uncertainties associated with the FM approach include modelling uncertainty when using Paris' law for crack growth prediction, measurement and statistical uncertainty associated with material properties, C and m , and initial crack size, a_0 , and modelling uncertainty associated with the calculation of stress range $\Delta\sigma$ (Souza and Ayyub 2000). Probabilistic modelling allows to explicitly address the uncertainties associated with

these parameters, to derive distributions of crack growth predictions, and to calculate failure probability caused by fatigue and fatigue reliability.

The material properties, C and m , are typically obtained by statistical analysis of results from specimen tests. The uncertainties associated with C and m are believed to be originated from the inhomogeneities in material, measurement method, procedure and statistical method for parameter estimation (Lassen and Recho 2013). Although typically understood as material properties, C and m are also influenced by environmental and loading conditions and they are correlated. Common practice is to assume that they are mutually independent, e.g., m is fixed and C is a variable. In a probabilistic analysis, C is typically assumed to be lognormally distributed (Guedes Soares and Garbatov 1998, Dong and Frangopol 2016, Faber et al. 2005, Lotsberg et al. 2016).

Representative statistical data on the initial crack size a_0 for specific applications is often hard to obtain due to challenges in sampling and measuring. A comprehensive review of the literature about the initial crack size can be found in (Zou, Banisoleiman, and González 2016). The initial crack size depends on many factors in design and manufacture that may not be easy to fully control, e.g. materials, welding techniques, NDT methods, quality control procedure and human factors, etc. The parameter a_0 is often modelled as a variable with a lognormal distribution (Kim and Frangopol 2011) or exponential distribution (Dong and Frangopol 2016, Lotsberg et al. 2016).

The uncertainty associated with the stress range $\Delta\sigma$ should be assessed on the basis of the uncertainty in the applied stress level, which includes the uncertainty in fatigue loading and in stress analysis method. These uncertainties can be quantified by systematic analysis of structural response data collected by measurement and calculation. In probabilistic fracture mechanics analysis, an additional variable can normally be introduced as a multiplication factor for the applied stress level (Lassen and Recho 2015).

3 Probabilistic frameworks for lifetime reliability and cost analysis

Table 1 summarizes the three maintenance strategies for structural integrity management under investigation. The first strategy labelled 'Case 1', is no action. The probability of fatigue failure is thus determined solely by design plan and manufacture quality control. This is the basic case. The second strategy, denoted by 'Case 2', consists of time-based maintenance without any inspection, e.g. time-based repair or replacement. The time for repair, t_r , is optimized for maximizing lifetime fatigue reliability. If the structure has survived at the planned repair time, a repair will be implemented. The

third strategy, i.e., 'Case 3', is condition-based maintenance, where damage condition is examined by inspection before a repair decision is made. The time for the inspection, t_i , is optimized with the same objective as 'Case 2'. If the structure has survived at the planned inspection time, an inspection will be carried out first. If a crack is detected, it will then be repaired. It is assumed that the repair is implemented shortly after detection, i.e., without delay, and that after repair, the structure returns to its initial state.

Table 1. Maintenance strategies under investigation.

Case	Maintenance strategy
Case 1	No action
Case 2	TBM (no inspection)
Case 3	CBM (inspection before repair)

3.1 Probabilistic maintenance optimization method

The maintenance strategies in Table 1 are optimized with the objective of maximizing lifetime fatigue reliability index. The fatigue reliability calculations without maintenance (Case 1) are performed via Monte Carlo simulation. The TBM and CBM strategies (Cases 2 and 3) leading to maximum reliability indexes are regarded as optimum ones. As both the structural damage state and inspection result are probabilistic at the decision analysis point in time, a decision tree analysis is implemented for Cases 2 and 3 before the fatigue reliability index with maintenance can be calculated. An exhaustive search algorithm can be employed for this optimization problem. Alternatively, if there are many optimization parameters, some optimization techniques can be adopted to reduce the time for deriving optimum solutions (Kim, Soliman, and Frangopol 2013).

3.1.1 Initial design fatigue reliability

The initial fatigue reliability is defined relative to the failure probability caused by fatigue without any maintenance (Case 1), which can be calculated by the probability of exceedance of a limit state signifying fatigue failure. The limit-state function is formulated based on the crack size in the thickness direction, as Equation (5).

$$M(t) = a_c - a(t) \quad (5)$$

where a_c is the critical crack size and $a(t)$ is the crack size at time t . Fatigue failure is defined as

the occurrence of through-thickness crack, i.e., the critical crack size, a_c , is set to be equal to the plate thickness T .

As both a_c and $a(t)$ can be expressed in number of cycles, the above limit state function can be re-written as Equation (6).

$$M(t) = N_F - N(t) \quad (6)$$

where N_F is the fatigue capacity and $N(t)$ is the fatigue loading by time t .

The probability of fatigue failure $P_f(t)$ and the fatigue reliability index β are given by Equations (7) and (8) respectively.

$$P_f(t) = P(M(t) \leq 0) \quad (7)$$

$$\beta(t) = -\Phi^{-1}[P_f(t)] \quad (8)$$

where $\Phi^{-1}[\cdot]$ is the inverse function of the standard normal cumulative density function.

3.1.2 Probability of repair

Decision tree analysis is implemented for the maintenance strategies involving maintenance actions (Cases 2 and 3), illustrated by Figures 3 and 4 respectively. In the figures, F, D, R represent failure, detection and repair respectively; $\bar{F}, \bar{D}, \bar{R}$ represent survival, no detection and no repair respectively; t_i is the time for inspection and t_r the time for repair. In the two cases, one maintenance intervention is planned to clearly present the differences between CBM and TBM in terms of their benefits and costs, and the Vol in CBM.

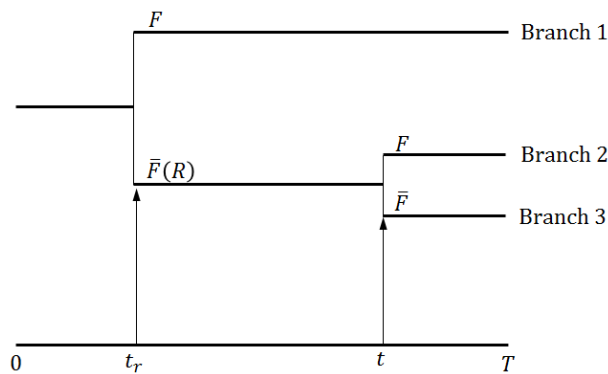

Figure 3. Illustration of a decision tree analysis for Case 2

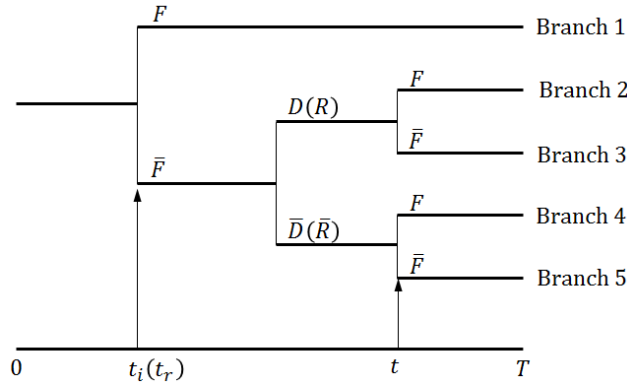

Figure 4. Illustration of a decision tree analysis for Case 3

In Case 2, no inspection is involved. Equation (9) gives the probability, $P_{rep}(t)$, of repair at time t , which is equal to the probability that the structure has survived at the time.

$$P_{rep}(t) = 1 - P_f(t) \quad (9)$$

In Case 3, the probability, $P_{insp}(t)$, of inspection at time t , is equal to the probability that the structure has survived at that time, given by Equation (10).

$$P_{insp}(t) = 1 - P_f(t) \quad (10)$$

In Case 3, the repair decision is dependent on the inspection result. The probability of repair at time t is equal to the probability that an inspection is implemented at that time with the inspection result being detection. If the detectable crack size of an NDT method (e.g. magnetic particle inspection) is a_d , then the limit state function for an inspection event can be formulated as:

$$D(t) = a_d - a(t) \quad (11)$$

The function is negative when a crack is detected and is otherwise positive. The probability of repair is given by Equation (12).

$$P_{rep}(t) = P(M(t) > 0 \cap D(t) < 0) \quad (12)$$

3.1.3 Fatigue reliability with maintenance

Let $P_f^1(t)$ designate the failure probability with maintenance and $\beta^1(t)$ the fatigue reliability index

with maintenance. When $t \leq t_r$, the planned maintenance action has not been implemented yet, and hence, the failure probability $P_f^1(t)$ will be equal to the initial failure probability without maintenance (Equation (13)).

$$P_f^1(t) = P_f(t) \quad (13)$$

When $t > t_r$, the influence of planned maintenance on the failure probability should be taken into account based on the decision tree analysis shown by Figures 3 and 4. The failure probability with maintenance for Case 2 and Case 3 are given by Equations (14) and (15) respectively, while the fatigue reliability index with maintenance, $\beta^1(t)$, is given by Equation (16).

$$P_f^1(t) = P_f(t_r) + P(M(t_r) > 0 \cap M(t - t_r) < 0) \quad (14)$$

$$P_f^1(t) = P_f(t_r) + P(M(t_r) > 0 \cap D(t_r) > 0 \cap M(t) < 0) + P(M(t_r) > 0 \cap D(t_r) < 0 \cap M(t - t_r) < 0) \quad (15)$$

$$\beta^1(t) = -\Phi^{-1} [P_f^1(t)] \quad (16)$$

The method can be applied to multiple inspections and repairs by doing decision tree analysis for a sequence of times at which inspections or repairs are scheduled. The number of branches of the decision trees in Figures 3 and 4 would increase exponentially with the number of inspections and repairs. The probability and reliability calculation would be more complex but can be done by common structural reliability calculation software or by programming.

3.2 Lifetime cost analysis framework

This paper focuses on structural integrity management at the operation stage. The time point of decision analysis is the beginning of the service life. This means that the structural integrity baseline has been established and the main tasks for integrity management are to develop a maintenance programme to maintain structural integrity. Equation (17) divides the life cycle costs (C) into inspection costs (C_I), repair costs (C_R) and failure cost (C_F).

$$C = C_I + C_R + C_F \quad (17)$$

Inspection, repair and failure costs are variables subjected to uncertainties associated with material and loading characteristics, inspection times and qualities, repair criteria and repair qualities. Lifetime cost analysis is based on the expected values of the inspection, repair and failure costs, and these costs are adjusted at the time of the cost analysis by an annual discounting rate of interest. Therefore,

inspection and repair costs can be defined by Equations (18) and (19) respectively.

$$C_I = \sum_{k=1}^{n_i} P_{insp}^k \cdot C_{insp}^k \cdot \frac{1}{(1+r)^{t_i^k}} \quad (18)$$

$$C_R = \sum_{k=1}^{n_r} P_{rep}^k \cdot C_{rep}^k \cdot \frac{1}{(1+r)^{t_r^k}} \quad (19)$$

where n_i and n_r are numbers of inspections and repairs in the life cycle; C_{insp}^k and C_{rep}^k are costs for the k th inspection and repair activity respectively; P_{insp}^k and P_{rep}^k are the probabilities of the k th inspection and repair actually being performed; t_i^k and t_r^k are the timing of the k th inspection and repair; and r is the annual discounting rate of interest.

The failure cost, C_F , is given by Equation (20).

$$C_F = P_f^n \cdot C_{fail} \cdot \frac{1}{(1+r)^{T_{SL}}} \quad (20)$$

where C_{fail} is the consequence of structural failure in terms of monetary loss; T_{SL} is the required service life, and; P_f^N is the probability of structural failure considering the planned inspections and repairs.

4 An illustrative example

The structural detail subjected to cyclic fatigue loading used as an example is a stiffened plate comprising of typical T joints. Figure 5 shows the geometry and critical location that were chosen for this joint. There are a large number of such joints in marine and offshore structures. Those areas where stiffeners are welded to the plate are critical as they are prone to crack initiation and propagation. The stability of the plate may be improved with stiffeners, but cracks are likely to initiate and propagate along the weld toes of joints due to welding notch, residual stresses, material inhomogeneity, etc. Fatigue reliability of such joints is thus an outstanding problem that needs to be addressed during the life cycle of the detail.

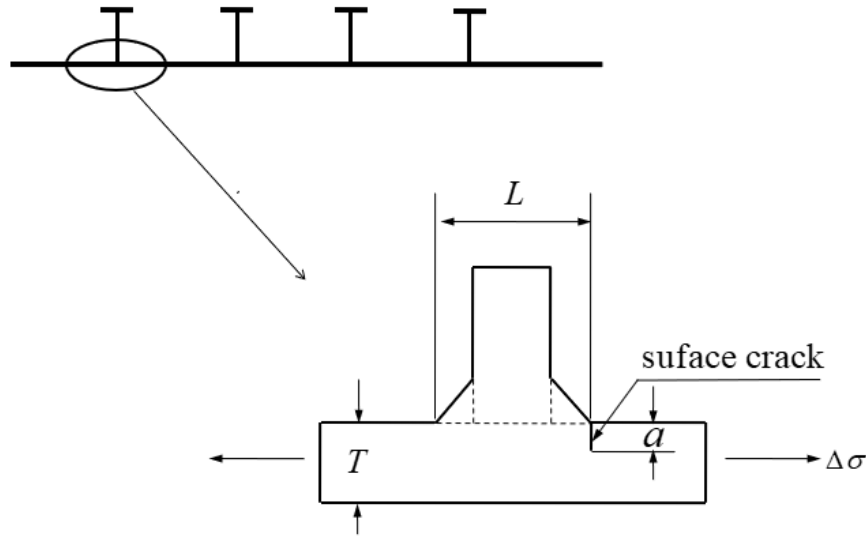

Figure 5. A typical stiffened plate with welded T joints.

First, the values of the parameters of the model defined in Section 2 are established for the structural detail based on existing literature. Then, the three maintenance strategies of Section 3 are tested. As mentioned in Section 3.2.1, Case 1 represents the initial fatigue reliability, which is determined by the structural plan and execution of manufacture quality control, without any operational maintenance. At the beginning of service life, the probabilistic maintenance optimization method and lifetime cost analysis framework are adopted to support the development of a maintenance program. Two different maintenance strategies are tested comparatively: Case 2 reflects the influence of time-based maintenance on lifetime fatigue reliability, while Case 3 reflects the influence of both inspection and repair. The time for the inspection, t_i , and for the repair, t_r , in Cases 2 and 3 are optimized for maximizing the lifetime fatigue reliability. The optimum maintenance strategies for Cases 2 and 3 are evaluated using the metric of life cycle costs, which is the sum of the financial costs associated with failure and the costs associated with the maintenance intervention as per Section 3.2.

4.1 Probabilistic models

The fatigue resistance of the structural detail is categorised as 'F' class by (DNV 2014), in which a bi-linear S-N model as Equation (3) with the parameters given in Table 2 is proposed to give its fatigue resistance. The required service life, T_{SL} , is assumed to be 20 years. The plate thickness, T , is adopted to be 25 mm. The critical crack size, a_c , is set to be equal to the plate thickness, i.e., $a_c = 25$ mm. The frequency of typical wave loading is approximately 0.16 Hz, which corresponds to $N_0 = 5 \times 10^6$ cycles per year (Lotsberg et al. 2016).

Table 2. Parameters used in reliability analysis.

Parameter	Unit	Value	Parameter	Unit	Value
T_{SL}	year	20	m_1	-	3
N_0	cycle	5×10^6	m_2	-	5
$\log_{10} \bar{a}_1$	$N^4 \cdot \text{mm}^{-6}$	11.855	a_c	mm	25
$\log_{10} \bar{a}_2$	$N^4 \cdot \text{mm}^{-6}$	15.091	a_d	mm	0.89

Table 3 provides the distributions and statistical characteristics for C and a_0 following (Lotsberg et al. 2016). The uncertainties associated with loads and stress calculations are modelled with a normally distributed variable B (Lassen and Recho 2015). Magnetic particle inspection is adopted for Case 3.

Sensitivity analysis of life cycle costs to the monetary cost of failure, C_{fail} , the cost of one repair, C_{rep} , and the cost of one inspection, C_{insp} , is carried out based on 9 sets of cost ratios (CR), which are referred to (Straub and Faber 2006, Kulkarni and Achenbach 2007, Breysse et al. 2009) and listed in Table 4. Herein CR1 is considered as baseline of cost values. The annual discounting rate of interest is taken as $r = 0$ so that the life cycle costs are determined only by the structural plan, fatigue loading, maintenance activities and associated uncertainties, i.e., ignoring social-economic factors.

Table 3. Uncertainty modelling used in reliability analysis.

Parameter	Distribution	Unit	Mean	Standard Deviation
a_0	Exponential	mm	0.043	0.043
$\log_{10} C$	Normal	$N^{-4} \cdot \text{mm}^{5.5}$	-12.74	0.11
B	Normal	-	1	0.15

Table 4. Life cycle costs for Case 1, 2, 3 under different cost ratios.

	CR1	CR2	CR3	CR4	CR5	CR6	CR7	CR8	CR9
C_{insp}	1	1	1	2	0.5	0.1	2	1	1
C_{rep}	10	20	5	10	10	20	4	10	10
C_{fail}	100	100	100	100	100	100	100	1000	50
C_{insp}/C_{rep}	0.1	0.05	0.2	0.2	0.05	0.005	0.5	0.1	0.1
C_{rep}/C_{fail}	0.1	0.2	0.05	0.1	0.1	0.2	0.04	0.01	0.2
$C_{case 1}$	13.23	13.23	13.23	13.23	13.23	13.23	13.23	132.7	6.64
$C_{case 2}$	10.78	20.74	5.81	10.78	10.78	20.74	4.81	18.39	10.37
$C_{case 3}$	4.54	7.66	2.99	5.55	4.05	6.76	3.68	8.52	4.33

$C_{case\ 3}/C_{case\ 2}$	0.42	0.37	0.51	0.51	0.38	0.33	0.77	0.46	0.42
$C_{case\ 3}/C_{case\ 1}$	0.34	0.58	0.23	0.42	0.31	0.51	0.28	0.06	0.65

4.2 Results and discussion

The probabilities, reliability indexes, and expected costs below are calculated with Monte Carlo simulations, with 5×10^6 samples for each variable. It is checked that more samples do not lead to much changes in the results. Figure 6 shows the decrease of fatigue reliability β with service year for Cases 1 and 2. It can be seen that with the adoption of TBM (e.g. a repair or replacement is planned at $t_r = 10$ years), the lifetime fatigue reliability index increases from 1.12 to 2.40.

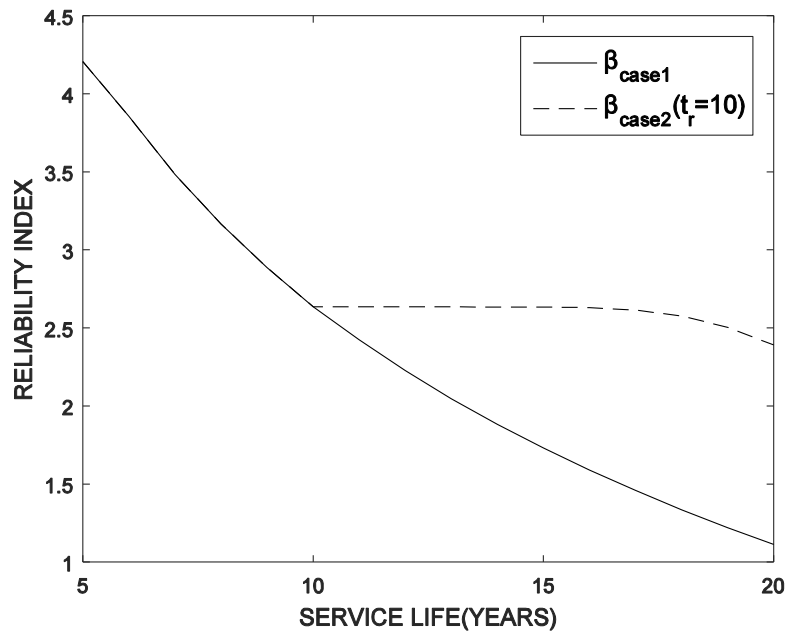

Figure 6. Fatigue reliability index β against service year

Figure 7 presents the influence of maintenance intervention time on lifetime fatigue reliability. Figures 8 – 10 show the influence of maintenance intervention time on life cycle costs.

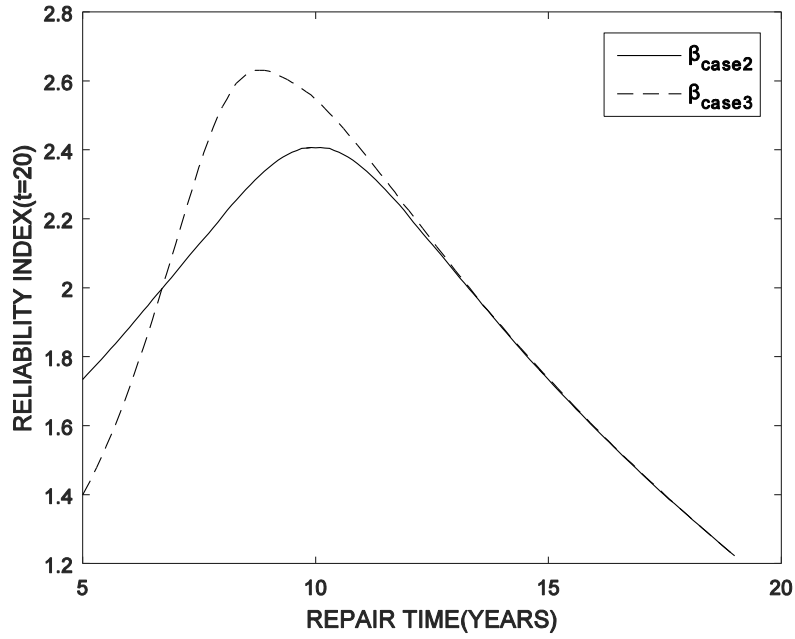

Figure 7. Fatigue reliability index against maintenance intervention time

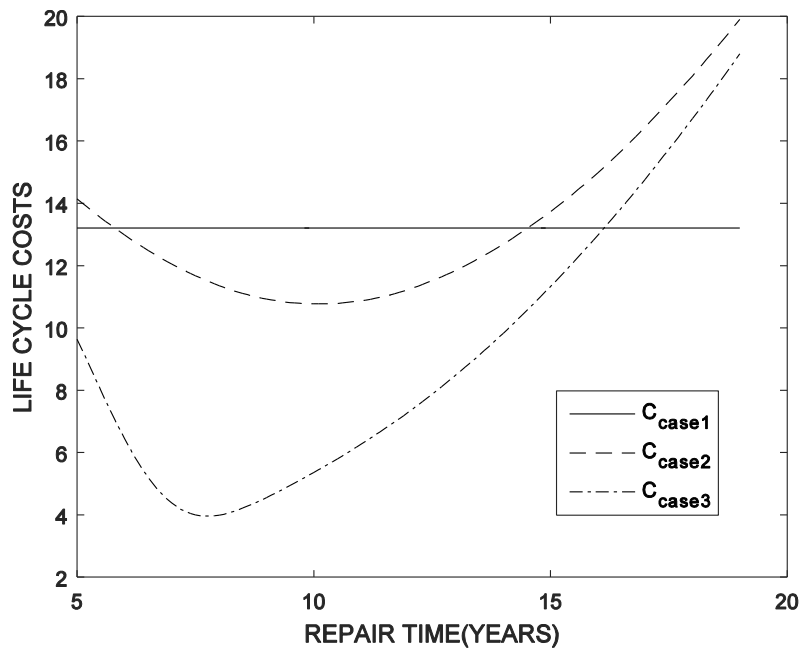

Figure 8. Life cycle costs against maintenance intervention time (CR1)

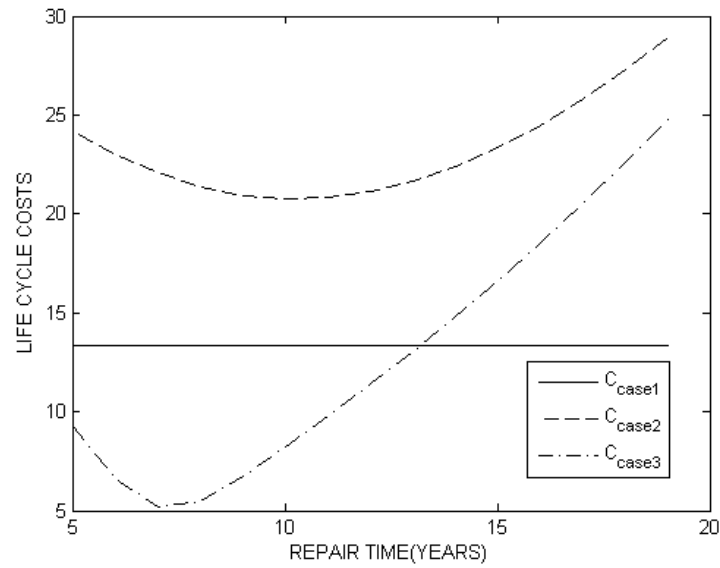

Figure 9. Life cycle costs against maintenance intervention time (CR6)

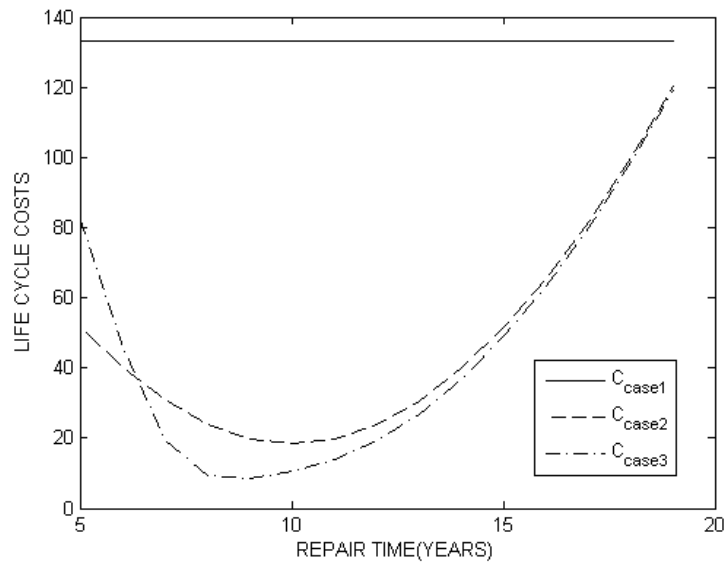

Figure 10. Life cycle costs against maintenance intervention time (CR8)

Table 5 summarizes the optimum maintenance strategies derived for Cases 2 and 3, the probability of inspection and, the probability of repair associated with the optimum strategies. The lifetime fatigue reliability index and life cycle costs (CR1) for Cases 1, 2 and 3 are also listed in Table 4, and they are evaluation metrics for the three maintenance strategies. The life cycle costs for Cases 1, 2 and 3 under all cost ratios are listed in Table 4. In Table 4, the efficiency of CBM is signified by $C_{case\ 3}/C_{case\ 1}$, as in Case 1, no maintenance intervention involves; while the advantage of CBM in terms of cost reduction in comparison to TBM is signified by $C_{case\ 3}/C_{case\ 2}$.

It should be noted that the results of lifetime fatigue reliability, probability of inspection and probability

of repair are independent on cost ratios (as can be seen from the formulations in Section 3), and life cycle costs are dependent on cost ratios. Sensitivity of maintenance efficiency and the advantage of CBM to cost ratios are analysed below:

- The efficiencies of both TBM and CBM increase with decrease of C_{rep}/C_{fail} . This conclusion is clearly shown by Table 4 and by comparison of Figure 8 to Figure 10. The conclusion indicates that it is more important and efficient to implement maintenance when the costs of repair is low compared with the costs of failure.
- The advantage of CBM in terms of cost reduction (in comparison to TBM) is more pronounced with decrease of C_{insp}/C_{rep} . This conclusion can be seen from Table 4 and from Figure 9, in comparison to Figure 8. In reality, the value of C_{insp}/C_{rep} is typically very small, as it is more convenient to do an inspection than to carry out a repair, which requires much more resources, e.g. money, materials, manhours, instrumentation, etc. In this regard, the advantage of CBM would be widely acknowledged with the development and popularity of inspection and monitoring techniques.

The above conclusions are the same as expected. It is more interesting to look at the results of lifetime fatigue reliability and probability of repair in Cases 2 and 3. The below discussions and conclusions are made mainly based on the results of lifetime fatigue reliability and probability of repair. When life cycle costs are mentioned, they are referred to CR1. Based on engineering experience and the references (Straub and Faber 2006, Kulkarni and Achenbach 2007, Breysse et al. 2009), it is believed that for most structural components, C_{insp}/C_{rep} is smaller than 0.1 and thus the advantage of CBM in cost reduction is more pronounced than shown by Figure 8.

Table 5. Optimum maintenance strategies

Notation	meaning	Case 1	Case 2	Case 3
β	Reliability index	1.12	2.40	2.62
t_i (year)	Inspection time	n/a	n/a	9
t_r (year)	Repair time	n/a	10	9
P_i	Inspection probability	n/a	n/a	0.998
P_r	Repair probability	n/a	0.996	0.311
$C(\text{CR1})$	Lifecycle costs	13.23	10.78	4.54

Based on Figures 6, 7, 8 and Table 5, the following points can be made about the structure detail under investigation:

- The optimum time for repair in Case 2 is approximately the middle of its service life (Figure 7). The lifetime fatigue reliability index increases to 2.40 from 1.12 in Case 1 (Figure 6), due to repair, by which the structure is physically changed. The life cycle costs drop slightly from 13.23 in Case 1 to 10.78 in Case 2 (Figure 8).
- With the adoption of inspection and possible repair (if detected), the lifetime fatigue reliability index increases significantly from 1.12 in Case 1 to 2.62 in Case 3 (Figure 7), and the life cycle costs drop significantly from 13.23 in Case 1 to 4.54 in Case 3 (Figure 8). The saving in life cycle costs benefits from both repair and inspection.
- By comparing Case 3 with Case 2, it is worth to highlight that more repairs do not necessarily lead to higher lifetime fatigue reliability. The probability of repair in Case 2 is much higher than in Case 3 (0.996 versus 0.311) as well as the lifetime total costs (10.78 versus 4.54). However, the lifetime fatigue reliability index in Case 2 is lower than that in Case 3 (2.40 versus 2.62) (Table 4). Hence, in certain conditions repair can be less beneficial to lifetime fatigue reliability compared with 'do nothing' and thus a waste of money. This is explained by the fact that damage extent can be mitigated by repair, but the uncertainties in material property and in stress range cannot be decreased. On the other hand, the information of no detection collected by an inspection implies slow deterioration rate and favourable material property and stress range. The failure probability may be decreased more significantly by the utilization of the information than by repair.
- The Vol provided by the inspection in Case 3 comes from two aspects. On the one hand, if the fatigue deterioration rate is fast, cracks would be detected and then repaired, by which the structure detail would be physically changed, and thus the failure probability is decreased, and failure risk is mitigated. In this circumstance, repair is beneficial to fatigue reliability. On the other hand, if the fatigue deterioration rate is slow, the most probable inspection result would be no detection. By utilization of the information, the failure probability is also decreased. In this circumstance, repair is ineffective or even unbeneficial to lifetime fatigue reliability. Therefore, an inspection can help to identify beneficial repair, unbeneficial repair and ineffective repair.

Even further, Figures 7 and 8 highlight the importance of optimizing inspection time in CBM and show when CBM strategy can be more beneficial than TBM strategy. Both the lifetime fatigue reliability and life cycle costs are strongly dependant on the inspection time. Based on the differences in Case 2 and Case 3 in terms of lifetime fatigue reliability (Figure 7) and life cycle costs (Figure 8), it is possible to distinguish three periods for inspection scheduling:

- An inspection scheduled at the late stage of service life, e.g. $t_i > 13$ years in this example, can identify and eliminate ineffective repair. The repair in Case 2 is regarded as ineffective, as it results in the same lifetime fatigue reliability as 'do nothing' in Case 3, in case of no detection at the late stage (Figure 7). The reason is that in case of no detection at the late stage, failure probability caused by fatigue is approximately zero, whether repaired or not. Thus, the life cycle costs in Case 3 is less than Case 2 (Figure 8), due to the elimination of ineffective repair by virtue of an inspection scheduled at the late stage.
- An inspection scheduled near the interim of service life, e.g. $7 \text{ years} < t_i < 13 \text{ years}$ in this example, can identify and eliminate unbeneficial repair. The repair in Case 2 is regarded as unbeneficial, as it leads to lower lifetime fatigue reliability than 'do nothing' in Case 3, in case of no detection in the interim (Figure 7). The reason is that no detection in the interim implies slow deterioration rate, and thus favourable material property and stress range. In such circumstances, the failure probability after repair can be higher than that of the original structure. Thus, the life cycle costs in Case 3 are much less than Case 2 (Figure 8), due to the elimination of unbeneficial repair and the lowest failure costs (the highest fatigue reliability), by virtue of an inspection scheduled near the interim of service life.
- An inspection scheduled at the early stage of service life, e.g. $t_i < 7$ years in this example, is likely to eliminate beneficial repair, although decreases life-cycle costs. In case of no detection at the early stage (Figure 7), The repair in Case 2 is regarded as beneficial, as it results in higher lifetime fatigue reliability than 'do nothing' in Case 3. The reason is that the implications of no detection at the early stage on lifetime failure probability are probably very weak compared with a repair. Thus, although the costs in Case 3 are less than Case 2 (Figure 8), due to less repair, the lifetime fatigue reliability in Case 3 is lower than Case 2 (Figure 7).

5 Conclusions

Current maintenance methods in the marine industry are still mainly corrective maintenance and time-based preventive maintenance (TBM). However, condition-based maintenance (CBM) has increasingly been a hot research topic, especially in industries such as wind power plants, nuclear plants, bridge engineering, etc. One factor, among many, impeding adoption of the new CBM strategy in marine engineering is probably lack of explicit and conclusive evidence of the benefits of CBM. This paper has carried out an investigation into the implications of a rational maintenance planning for a marine structure detail. A probabilistic maintenance optimization method and a lifetime cost analysis framework has been built upon life cycle analysis, probabilistic modelling and decision tree analysis. The method and the framework have enabled direct modelling and integrated management of the

uncertainties affecting fatigue deterioration and maintenance activities and can be used to support rational and optimal maintenance planning under uncertainty. Employing the method and the framework, two maintenance strategies (TBM and CBM) have been optimized and evaluated based on the metrics of lifetime fatigue reliability and total costs. By comparison to TBM, the benefits of the CBM strategy to lifetime fatigue reliability and cost reduction, the conditions when the TBM strategy can be more beneficial than the CBM, and when a repair can be beneficial, unbeneficial or ineffective to lifetime fatigue reliability have been discussed. Based on the classification of repair, the value of information (Vol) provided by inspection in the CBM strategy and, the conditions when the Vol can be realized and maximized have been discussed. In summary:

- 1) Compared with 'do nothing', repair can be less beneficial to lifetime fatigue reliability when there is a high degree of uncertainties in material property and in stress range. In such conditions, repairing relatively small cracks, which would be implemented under the TBM strategy but can be avoided under the CBM strategy, would be unbeneficial to lifetime fatigue reliability. If a CBM strategy was to repair detected cracks, it is not recommended to use a very accurate inspection method (with very small detectable crack size) for inspections scheduled at the late stage, to avoid unbeneficial repair.
- 2) Repair is classified into beneficial, ineffective and unbeneficial repair, according to their benefits to lifetime fatigue reliability. Classification of repair is important for making clear the Vol provided by inspection in the CBM strategy, maximizing the Vol and thus improving the efficiency of a maintenance strategy. Inspection can help to identify beneficial, unbeneficial and ineffective repair, in addition, to identifying cracks.
- 3) The Vol provided by inspection in the CBM strategy comes from two aspects. On the one hand, if the fatigue deterioration rate is fast, cracks would be identified by the inspection, and subsequently repaired. After repair, the lifetime fatigue reliability of the structure detail would be higher than prior to repair due to the elimination of serious damages. On the other hand, if the fatigue deterioration rate is slow, the most likely inspection result would be no detection. Utilizing this additional information, the lifetime fatigue reliability would be higher than before inspection.
- 4) The Vol is maximized when the unbeneficial repair can be identified and eliminated. Based on an illustrative example, to reap the maximum Vol, it is required that an inspection method with appropriate quality is adopted and that the inspection is scheduled near the interim of service life. The maximum Vol is achieved by virtue of elimination of unbeneficial repair and the lowest failure costs. Ineffective repair can be avoided with an inspection scheduled at the late stage of service life. The reason is that lifetime fatigue reliability would be the same in case of no

detection at the late stage of service life, whether repaired or not.

- 5) Based on an illustrative example, (a) if inspection was scheduled near the interim of service life, the CBM strategy is more beneficial than the TBM strategy in terms of both lifetime fatigue reliability and costs; (b) if inspection was scheduled at the late stage of service life, the CBM strategy is more beneficial than the TBM strategy in terms of life cycle costs and is the same as the TBM strategy in terms of lifetime fatigue reliability; and (c) if inspection was scheduled at the early stage of service life, the CBM strategy can be superior or inferior (when C_{rep}/C_{fail} is very small, as shown by Figure 10) to the TBM strategy in terms of life cycle costs, but is less beneficial than the TBM strategy in terms of lifetime fatigue reliability.

In future work, the methodology can be extended to maintenance strategy of multiple inspections and repairs by doing decision tree analysis for a sequence of times at which inspections or repairs are scheduled. The branches in the decision tree would increase exponentially with the number of inspections or repairs in lifetime. The life cycle costs can still be calculated by Equation (17) – (20). It is expected that unbeneficial and ineffective maintenance are more likely to be identified by CBM with multiple inspections.

ACKNOWLEDGEMENTS

The authors would like to express their gratitude to the European Union's Horizon 2020 research and innovation programme for their funding toward this project under the Marie Skłodowska-Curie grant agreement No. 642453 (<http://trussitn.eu>).

REFERENCES

- Baraldi, Piero, Roberto Canesi, Enrico Zio, Redouane Seraoui, and Roger Chevalier. 2011. "Genetic algorithm-based wrapper approach for grouping condition monitoring signals of nuclear power plant components." *Integrated computer-Aided engineering* 18 (3):221-234.
- Biondini, Fabio, and Dan M Frangopol. 2016. "Life-cycle performance of deteriorating structural systems under uncertainty." *Journal of Structural Engineering* 142 (9):F4016001.
- Breyse, Denys, Sidi Mohammed Elachachi, Emma Sheils, Franck Schoefs, and Alan O'connor. 2009. "Life cycle cost analysis of ageing structural components based on non-destructive condition assessment." *Australian Journal of Structural Engineering* 9 (1):55-66.
- Cullum, Jane, Jonathan Binns, Michael Lonsdale, Rouzbeh Abbassi, and Vikram Garaniya. 2018. "Risk-Based Maintenance Scheduling with application to naval vessels and ships." *Ocean Engineering* 148:476-485.
- DNV, GL. 2014. DNVGL-RP-0005: Fatigue design of offshore steel structures. Det Norske Veritas AS, Oslo, Norway.
- Dong, Y., and D. M. Frangopol. 2016. "Incorporation of risk and updating in inspection of fatigue-sensitive details of ship structures." *International Journal of Fatigue* 82:676-688. doi: 10.1016/j.ijfatigue.2015.09.026.

- Emovon, Ikuobase, Rosemary A. Norman, and Alan J. Murphy. 2016. "An integration of multi-criteria decision making techniques with a delay time model for determination of inspection intervals for marine machinery systems." *Applied Ocean Research* 59:65-82. doi: <https://doi.org/10.1016/j.apor.2016.05.008>.
- Faber, Michael Havbro, Daniel Straub, and Jean Goyet. 2003. "Unified approach to risk-based inspection planning for offshore production facilities." *Journal of Offshore Mechanics and Arctic Engineering* 125 (2):126-131. doi: 10.1115/1.1555116.
- Faber, Michael Havbro, John D. Sørensen, Jesper Tychsen, and Daniel Straub. 2005. "Field implementation of RBI for jacket structures." *Journal of Offshore Mechanics and Arctic Engineering* 127 (3):220-226. doi: 10.1115/1.1951777.
- Fricke, Wolfgang. 2003. "Fatigue analysis of welded joints: state of development." *Marine Structures* 16 (3):185-200. doi: [http://dx.doi.org/10.1016/S0951-8339\(02\)00075-8](http://dx.doi.org/10.1016/S0951-8339(02)00075-8).
- Guedes Soares, C., and Y. Garbatov. 1998. "Reliability of maintained ship hull girders subjected to corrosion and fatigue." *Structural Safety* 20 (3):201-219. doi: 10.1016/S0167-4730(98)00005-8.
- Guo, Jinting Jeffrey, Ge George Wang, Anastassios N Perakis, and Lyuben Ivanov. 2012. "A study on reliability-based inspection planning—Application to deck plate thickness measurement of aging tankers." *Marine Structures* 25 (1):85-106.
- Jiang, Ren-yan. 2010. "Optimization of alarm threshold and sequential inspection scheme." *Reliability Engineering & System Safety* 95 (3):208-215.
- Kallen, Maarten-Jan, and Jan M van Noordwijk. 2005. "Optimal maintenance decisions under imperfect inspection." *Reliability Engineering & System Safety* 90 (2-3):177-185.
- Kim, Sunyong, and Dan M Frangopol. 2011. "Optimum inspection planning for minimizing fatigue damage detection delay of ship hull structures." *International Journal of Fatigue* 33 (3):448-459.
- Kim, Sunyong, Mohamed Soliman, and Dan M. Frangopol. 2013. "Generalized Probabilistic Framework for Optimum Inspection and Maintenance Planning." *Journal of Structural Engineering* 139 (3):435-447. doi: 10.1061/(ASCE)ST.1943-541X.0000676.
- Konakli, Katerina, Bruno Sudret, and Michael H Faber. 2015. "Numerical investigations into the value of information in lifecycle analysis of structural systems." *ASCE-ASME Journal of Risk and Uncertainty in Engineering Systems, Part A: Civil Engineering* 2 (3):B4015007.
- Kulkarni, Salil S, and Jan D Achenbach. 2007. "Optimization of inspection schedule for a surface-breaking crack subject to fatigue loading." *Probabilistic Engineering Mechanics* 22 (4):301-312.
- Lassen, Tom, and Naman Recho. 2013. *Fatigue Life Analyses of Welded Structures: Flaws*. John Wiley & Sons.
- Lassen, Tom, and Naman Recho. 2015. "Risk based inspection planning for fatigue damage in offshore steel structures." ASME 2015 34th International Conference on Ocean, Offshore and Arctic Engineering.
- Lotsberg, Inge, Gudfinnur Sigurdsson, Arne Fjeldstad, and Torgeir Moan. 2016. "Probabilistic methods for planning of inspection for fatigue cracks in offshore structures." *Marine Structures* 46:167-192. doi: <http://dx.doi.org/10.1016/j.marstruc.2016.02.002>.
- Lu, Yang, Liping Sun, Xinyue Zhang, Feng Feng, Jichuan Kang, and Guoqiang Fu. 2018. "Condition based maintenance optimization for offshore wind turbine considering opportunities based on neural network approach." *Applied Ocean Research* 74:69-79. doi: <https://doi.org/10.1016/j.apor.2018.02.016>.
- Malings, C, and M Pozzi. 2018. "Value-of-information in spatio-temporal systems: Sensor placement and scheduling." *Reliability Engineering & System Safety* 172:45-57.
- Memarzadeh, Milad, Matteo Pozzi, and J Zico Kolter. 2016. "Hierarchical modeling of systems with similar components: A framework for adaptive monitoring and control." *Reliability Engineering & System Safety* 153:159-169.

- Moan, T. 2011. "Life-cycle assessment of marine civil engineering structures." *Structure and Infrastructure Engineering* 7 (1-2):11-32.
- Paris, PC, and Fazil Erdogan. 1963. "A critical analysis of crack propagation laws." *Journal of Basic Engineering* 85 (4):528-533.
- Rinaldi, G, PR Thies, R Walker, and L Johanning. 2017. "A decision support model to optimise the operation and maintenance strategies of an offshore renewable energy farm." *Ocean Engineering* 145:250-262.
- Sabatino, Samantha, and Dan M Frangopol. 2017. "Decision making framework for optimal SHM planning of ship structures considering availability and utility." *Ocean Engineering* 135:194-206.
- Sebastian, Thöns. 2018. "On the Value of Monitoring Information for the Structural Integrity and Risk Management." *Computer-Aided Civil and Infrastructure Engineering* 33 (1):79-94. doi: doi:10.1111/mice.12332.
- Soliman, Mohamed, Dan M. Frangopol, and Alysson Mondoro. 2016. "A probabilistic approach for optimizing inspection, monitoring, and maintenance actions against fatigue of critical ship details." *Structural Safety* 60:91-101. doi: 10.1016/j.strusafe.2015.12.004.
- Souza, GFM, and BM Ayyub. 2000. "Probabilistic fatigue life prediction for ship structures using fracture mechanics." *Naval engineers journal* 112 (4):375-397.
- Straub, Daniel, and Michael H Faber. 2006. "Computational aspects of risk-based inspection planning." *Computer-Aided Civil and Infrastructure Engineering* 21 (3):179-192.
- Temple, DW, and MD Collette. 2015. "Minimizing lifetime structural costs: Optimizing for production and maintenance under service life uncertainty." *Marine Structures* 40:60-72.
- Ventikos, NP, P Sotiralis, and M Drakakis. 2018. "A dynamic model for the hull inspection of ships: The analysis and results." *Ocean Engineering* 151:355-365.
- Verbert, Kim, Bart De Schutter, and R Babuška. 2017. "Timely condition-based maintenance planning for multi-component systems." *Reliability Engineering & System Safety* 159:310-321.
- Wang, Haibin, Elif Oguz, Byongug Jeong, and Peilin Zhou. 2018. "Life cycle cost and environmental impact analysis of ship hull maintenance strategies for a short route hybrid ferry." *Ocean Engineering* 161:20-28.
- Wang, Peng, Xinliang Tian, Tao Peng, and Yong Luo. 2018. "A review of the state-of-the-art developments in the field monitoring of offshore structures." *Ocean Engineering* 147:148-164.
- Yang, David Y, and Dan M Frangopol. 2018. "Probabilistic optimization framework for inspection/repair planning of fatigue-critical details using dynamic Bayesian networks." *Computers & Structures* 198:40-50.
- Yang, Li, Yu Zhao, and Xiaobing Ma. 2018. "Multi-level maintenance strategy of deteriorating systems subject to two-stage inspection." *Computers & Industrial Engineering* 118:160-169.
- Zerbst, U., R. A. Ainsworth, H. T. Beier, H. Pisarski, Z. L. Zhang, K. Nikbin, T. Nitschke-Pagel, S. Munstermann, P. Kucharczyk, and D. Klingbeil. 2014. "Review on fracture and crack propagation in weldments - A fracture mechanics perspective." *Engineering Fracture Mechanics* 132:200-276. doi: 10.1016/j.engfracmech.2014.05.012.
- Zhao, Xuejing, Mitra Fouladirad, Christophe Bérenguer, and Laurent Bordes. 2010. "Condition-based inspection/replacement policies for non-monotone deteriorating systems with environmental covariates." *Reliability Engineering & System Safety* 95 (8):921-934.
- Zhou, Xiaojun, Lifeng Xi, and Jay Lee. 2007. "Reliability-centered predictive maintenance scheduling for a continuously monitored system subject to degradation." *Reliability Engineering & System Safety* 92 (4):530-534.

Zou, Guang, Kian Banisoleiman, and Arturo González. 2016. "Methodologies for crack initiation in welded joints applied to inspection planning." *World Academy of Science, Engineering and Technology* 10 (11):1406-1413.