



Title	Power Adaptive Decomposed Vector Rotation Based Digital Predistortion for RF Power Amplifiers in Dynamic Power Transmission
Authors(s)	Guo, Yan, Zhu, Anding
Publication date	2017-01-18
Publication information	Guo, Yan, and Anding Zhu. "Power Adaptive Decomposed Vector Rotation Based Digital Predistortion for RF Power Amplifiers in Dynamic Power Transmission." IEEE, January 18, 2017. https://doi.org/10.1109/PAWR.2017.7875559 .
Conference details	2017 IEEE Topical Conference on RF/Microwave Power Amplifiers for Radio and Wireless Applications (PAWR), Phoenix, Arizona, USA, 15-18 January 2017
Publisher	IEEE
Item record/more information	http://hdl.handle.net/10197/8513
Publisher's statement	© 2017 IEEE. Personal use of this material is permitted. Permission from IEEE must be obtained for all other uses, in any current or future media, including reprinting/republishing this material for advertising or promotional purposes, creating new collective works, for resale or redistribution to servers or lists, or reuse of any copyrighted component of this work in other works.
Publisher's version (DOI)	10.1109/PAWR.2017.7875559

Downloaded 2026-05-01 23:34:27

The UCD community has made this article openly available. Please share how this access benefits you. Your story matters! (@ucd_oa)



© Some rights reserved. For more information

Power Adaptive Decomposed Vector Rotation Based Digital Predistortion for RF Power Amplifiers in Dynamic Power Transmission

Yan Guo and Anding Zhu

RF and Microwave Research Group, University College Dublin, Ireland

Abstract — In this paper, a power adaptive digital predistortion (DPD) model is proposed to linearize RF power amplifiers (PAs) operated in dynamic power transmissions. By employing the decomposed vector rotation (DVR) based nonlinear weighting technique to adjust the DPD coefficients dynamically, the distortion induced by the dynamic power operation can be effectively compensated. Experimental test results with a high power Gallium Nitride (GaN) Doherty PA confirm that higher linearization performance can be achieved by employing this model, compared to that using the existing approaches.

Index Terms — dynamic power transmission, digital predistortion, decomposed vector rotation model, RF power amplifiers.

I. INTRODUCTION

Digital predistortion (DPD) has been widely used in cellular base stations for linearizing RF power amplifiers (PAs). Its performance, however, can be deteriorated due to the PA behavior changes induced by variations of the transmit power, shown in Fig. 1. This is because the PA is a nonlinear device and thereby power changes at the input can significantly affect its nonlinear behavior. To properly compensate for the distortion caused by the power changes, DPD must be recalibrated in real-time, which is often not feasible in practice.

To resolve this issue, a long term memory Volterra model was proposed in [1]. This method is able to improve the performance in the scenario of two different power levels, but has limited performance when the PA is operated in a large dynamic power range. A power adaptive DPD approach in [2] was proposed to further improve the modeling accuracy in the cases of multiple

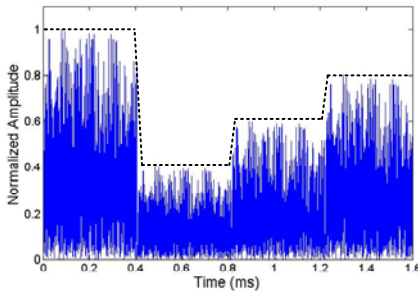

Fig. 1. An example of signal power changes

power levels. The high model accuracy however comes with the price of complex control logic, which increases implementation complexity. A cost-effective solution with straight forward implementation structure is therefore desirable.

In this paper, a novel DPD model called power adaptive decomposed vector rotation (PDVR) model is proposed. The PA nonlinearity in this model is characterized by a nonlinear interaction between the input signal and the average input power so that the PA behavior during dynamic power transmission can be accurately characterized. Additionally, the model structure is built on the low order DVR terms, and the required control logic can be conducted in a compact and straightforward manner, which facilitates practical implementation.

II. POWER ADAPTIVE DVR DPD

A. Generalized Model Architecture

The long term memory Volterra (LTM-V) model in [1] can be represented in the following generalized form:

$$\tilde{y}(n) = F[\tilde{x}(n)] + s(n) \times \Delta F[\tilde{x}(n)], \quad (1)$$

where $\tilde{x}(n)$ and $\tilde{y}(n)$ are the baseband envelope of the PA input and output, respectively. $s(n)$ is the average power variable over a finite length time window. F and ΔF denotes the Volterra based DPD function, and they usually have the same model structure. The model in (1) has a straightforward architecture and higher modeling accuracy compared to the conventional method. However, since the PA nonlinear change is simply modeled as a point-wise linear interaction between the model terms and $s(n)$, its model capacity in the scenario of multiple power levels is limited. To overcome this, [2] proposed to weight the linear and nonlinear terms separately, meaning that:

$$\tilde{y}(n) = F[\tilde{x}(n)] + \alpha_{ln}^{(r)} \times \Delta f_{ln}[\tilde{x}(n)] + \alpha_{nl}^{(r)} \times \Delta f_{nl}[\tilde{x}(n)], \quad (2)$$

where the $\alpha_{ln}^{(r)}$ and $\alpha_{nl}^{(r)}$ are the scaling factors for the linear and nonlinear part at the r^{th} power level, respectively. Δf_{ln} and Δf_{nl} stands for the linear and

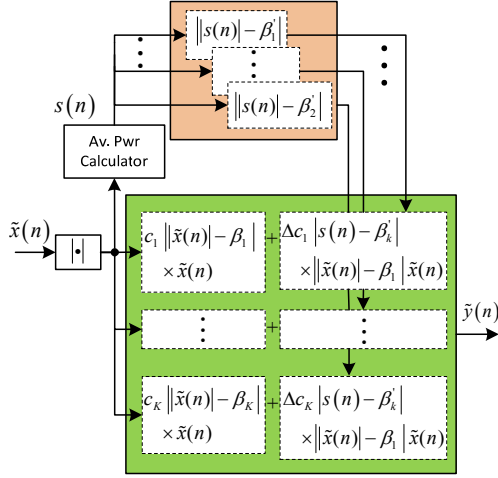

Fig. 2. The power adaptive DVR DPD model.

nonlinear part, respectively. The separate weighting strategy greatly enhances model accuracy. Consequently, the starting and ending time of each power level must be carefully determined in order to properly switch the weighting factors, which complicates practical implementation.

To achieve low implementation cost and high model accuracy simultaneously, the advantages of above two methods can be combined to form a new model structure,

$$\tilde{y}(n) = F[\tilde{x}(n)] + \sum_{l=1}^L \alpha_l [s(n)] \times \Delta f_l [\tilde{x}(n)], \quad (3)$$

where α_l , ($l=1,2,\dots,L$) is a point-wise nonlinear scaling function constructed by $s(n)$. Δf_l reflects the l^{th} order dynamic model terms. In (3), each order of model terms can be weighted separately by different scaling functions. There is no complex control logic required except the calculation of $s(n)$.

B. PDVR Model

Equation (3) cannot be implemented by using the Volterra based functions because the change patterns of the each order term in Volterra model are very difficult to obtain. Fortunately, the DVR model proposed in [3]:

$$\begin{aligned} \tilde{y}(n) = & \sum_{m=0}^M a_m \tilde{x}(n-m) \\ & + \sum_{k=1}^K \sum_{m=1}^M c_{km} \left| |\tilde{x}(n-m) - \beta_k| \cdot \tilde{x}(n-m), \right. \end{aligned} \quad (4)$$

is able to overcome this difficulty. The a_m and c_{km} are the complex coefficients, and β_k is the partitioning threshold. The modeling results confirm that this signal envelope based partitioning approach is highly efficient in fitting a wide range of nonlinear functions [3]. If we take

advantage of this feature to fit the power-related nonlinearity change, namely, replacing the instant amplitude $|\tilde{x}(n)|$ in the DVR process by $s(n)$ to build the nonlinear weighting function α in (3), the PDVR model can be expressed as:

$$\begin{aligned} \tilde{y}(n) = & \sum_{m=0}^M a_m \tilde{x}(n-m) + \sum_{m=0}^M s(n) \times \Delta a_m \tilde{x}(n-m) \\ & + \sum_{k=1}^K \sum_{m=1}^M c_{km} \left| |\tilde{x}(n-m) - \beta_k| \cdot \tilde{x}(n-m) \right. \\ & \left. + \sum_{k=1}^K |s(n) - \beta'_k| \times \sum_{m=1}^M \Delta c_{k,m} \left| |\tilde{x}(n-m) - \beta_k| \cdot \tilde{x}(n-m), \right. \right. \end{aligned} \quad (5)$$

$s(n)$ is defined by the IIR method in [4]:

$$s(n) = w \times |\tilde{x}(n)| + (1-w) \times s(n-1), \quad (6)$$

where w ($w \ll 1$) is a weighting factor.

The model capacity of (5) has been significantly improved. Given three signal samples with similar magnitudes but at different average power levels, that is:

$$\begin{cases} \tilde{x}(n_1) \approx \tilde{x}(n_2) \approx \tilde{x}(n_3) \\ s(n_1) < s(n_2) < s(n_3) \end{cases}, \quad (7)$$

The adjustments for the three samples are then shown as:

$$\begin{cases} \left| |s(n_1) - \beta'_1|, |s(n_1) - \beta'_2|, \dots, |s(n_1) - \beta'_K| \right. \\ \left| |s(n_2) - \beta'_1|, |s(n_2) - \beta'_2|, \dots, |s(n_2) - \beta'_K| \right. \\ \left| |s(n_3) - \beta'_1|, |s(n_3) - \beta'_2|, \dots, |s(n_3) - \beta'_K| \right. \end{cases} \quad (8)$$

Assuming the three power levels are set as: $\beta'_1 < s(n_1) < \beta'_2$, $\beta'_2 < s(n_2) < \beta'_3$, and $\beta'_{K-1} < s(n_3) < \beta'_K$. The absolute operators in (8) can thus be obtained as:

$$\begin{cases} \left| |s(n_1) - \beta'_1|, \beta'_2 - |s(n_1)|, \dots, \beta'_K - |s(n_1)| \right. \\ \left| |s(n_2) - \beta'_1|, |s(n_2) - \beta'_2|, \dots, \beta'_K - |s(n_2)| \right. \\ \left| |s(n_3) - \beta'_1|, |s(n_3) - \beta'_{K-1}|, \dots, \beta'_K - |s(n_3)| \right. \end{cases} \quad (9)$$

From (9), we can see that, if the power levels of the first and second samples are relatively close, the difference between the two weighting factors will be very small, and therefore the transfer function at n_1 and n_2 will be similar. While for the third sample n_3 , its power level is much higher than the one at first or second sample, the corresponding nonlinear change pattern will be very different. Under such circumstances, most of the dynamic terms of the third sample are different from those at the n_1 and n_2 , the PA behavior change at this power level is then distinguished nonlinearly from the others. Therefore, the

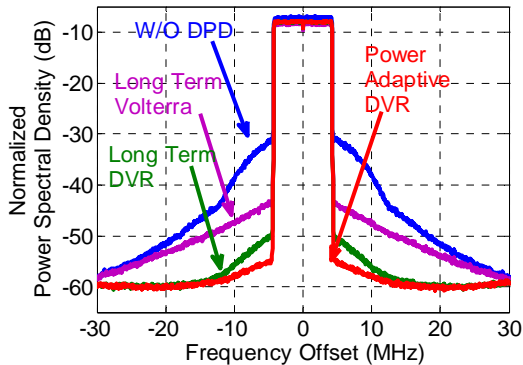

Fig. 3. Experimental results.

differentiation degree of the PA behavior at each power level is increased by using this independent weighting method which will enhance the overall modeling accuracy. The model architecture can be represented as the block diagram in Fig. 2. In practical transmission, the baseband envelope will be used to calculate $s(n)$ which is then employed to obtain the nonlinear weighting factor $|s(n) - \beta_k|$. The coefficients adjustments can be conveniently achieved by using $|s(n) - \beta_k| \times \Delta c_{km}$. Hence, the PDVR model architecture brings higher model accuracy without involving complex control process.

IV. MEASUREMENTS RESULTS

To evaluate the PDVR method, a high power GaN Doherty PA is tested. In the transmitter side, the baseband signal is first generated in PC MATLAB and fed into the E4438C signal generator for up-conversion. The resulting RF signal is then amplified linearly by a driver amplifier and sent to the main PA. In the feedback loop, the PA output signal is captured and down-converted to digital baseband by an E4445A spectrum analyzer and then sent back to PC for model extraction. A four power levels (lasting 2 ms at each power level roughly) 10 MHz LTE signal as shown in Fig. 1 is employed to stimulate the PA. During the test, 40,000 samples are used for model extraction, while the entire 61, 0404 samples are used for model validation. Three different measurements are conducted: (1) The LTM-V [1] with nonlinear order 9 and memory length 3; (2) the long term memory DVR (LTM-D) method achieved by replacing Volterra terms in (1) by DVR terms; (3) the PDVR model. The decomposition level and memory length are set to 8 and 3, respectively in both LTM-D and PDVR cases. The weighting factor w in

TABLE I
NMSE PERFORMANCE AND MODEL COMPLEXITY COMPARISON

	NO DPD	LTM-V	LTM-D	PDVR
NMSE (dB)	-16.33	-26.41	-34.17	-38.35
Coeff. No.	0	57*2	34*2	34*2

(6) is set as 0.001 for accurate power tracking. The measurements results are shown in Fig. 3 and TABLE I, respectively.

Due to large input power dynamics, the PA exhibits strong and complex nonlinear distortion, which cannot be effectively compensated by the LTM-V model. The NMSE is only around -26 dB and the ACPR value is clearly violating the existing spectrum regulations. The linearization performance is significantly improved by adopting the LTM-D approach. This is because the envelope-based partitioning in DVR terms is able to provide better differentiation of the nonlinearity at each power level. However, there is still considerable amount of distortion left after using LTM-D. By using the PDVR method, the PA can be accurately linearized. There are over 4dB NMSE and 5dBc ACPR improvements compared to the LTM-D method. It thus confirms that the independent nonlinear weighting approach in PDVR method is able to achieve higher linearization performance in complex dynamic power cases.

VII. CONCLUSION

A new power adaptive DVR DPD is introduced in this paper to provide a cost-effective and high performance solution for PA linearization in dynamic power transmission. By using the DVR based nonlinear weighting method to adjust the model coefficients, the PA dynamic behavior change induced by the power variation can be accurately compensated.

ACKNOWLEDGEMENT

This publication has emanated from research supported in part by research grants from Science Foundation Ireland (SFI) and is co-funded under the European Regional Development Fund under Grant Numbers 13/RC/2077 and 12/IA/1267.

REFERENCES

- [1] A. S. Tehrani, T. Eriksson, and C. Fager, "Modeling of long term memory effects in RF power amplifiers with dynamic parameters," in *Proc. IEEE MTT-S Int. Microw. Symp. Dig.*, Montreal, QC, Canada, Jun. 2012, pp. 1-3.
- [2] Y. Guo, C. Yu, and A. Zhu "Power adaptive digital predistortion for wideband RF power amplifier with dynamic power transmission" TMTT," *IEEE Trans. Microw. Theory Techn.*, vol. 63, no. 11, pp. 3595-3607, Nov. 2015.
- [3] A. Zhu, "Decomposed vector rotation-based behavioral modeling for digital predistortion of RF power amplifiers," *IEEE Trans. Microw. Theory Techn.*, vol. 63, no. 2, pp. 737-744, Feb. 2015.
- [4] V. P. G Jimenez, M. J. F. Garcia, F. J. G. Serrano, "Design and implementation of synchronization and AGC for OFDM-base WLAN receivers," *IEEE Trans. Consumer Electronics*, vol. 50, pp. 1016-1025, Nov. 2004.