



Title	Robust optimization based self scheduling of hydro-thermal Genco in smart grids
Authors(s)	Soroudi, Alireza
Publication date	2013-11
Publication information	Soroudi, Alireza. "Robust Optimization Based Self Scheduling of Hydro-Thermal Genco in Smart Grids." Elsevier, November 2013. https://doi.org/10.1016/j.energy.2013.09.014 .
Publisher	Elsevier
Item record/more information	http://hdl.handle.net/10197/6154
Publisher's statement	This is the author's version of a work that was accepted for publication in Energy. Changes resulting from the publishing process, such as peer review, editing, corrections, structural formatting, and other quality control mechanisms may not be reflected in this document. Changes may have been made to this work since it was submitted for publication. A definitive version was subsequently published in Energy (VOL 61, ISSUE 2013, (2013)) DOI:10.1016/j.energy.2013.09.014
Publisher's version (DOI)	10.1016/j.energy.2013.09.014

Downloaded 2026-05-02 00:24:25

The UCD community has made this article openly available. Please share how this access benefits you. Your story matters! (@ucd_oa)



© Some rights reserved. For more information

Robust optimization based self scheduling of hydro-thermal Genco in smart grids

Alireza Soroudi^{*,a}

^aYoung researcher society, Tehran, Iran, Tehran, Iran.

Abstract

This paper proposes a robust optimization model for optimal self scheduling of a hydro-thermal generating company. The proposed model is suitable for price taker Gencos which seeks the optimal schedule of its thermal and hydro generating units for a given operating horizon. The uncertainties of electricity prices are modeled using robust optimization approach to make it more practical. It considers various technical constraints like water balance and water traveling time between cascaded power stations and emission allowance. Finally, different case studies are analyzed to demonstrate the strength of the proposed methodology.

Key words: Robust optimization, hydro-thermal scheduling, uncertainty modeling, smart grids.

Nomenclature

λ_t^a Actual value of electricity price in time t

Γ Budget of uncertainty

β, ξ_t Dual variables of robust optimization

$P_{i,t}$ Generated power of thermal unit i in time t (MW)

$P_{h,t}$ Generated power of hydro unit h in time t .

t Hour index

$\hat{\lambda}_t$ Maximum deviation of actual value from the predicted value of electricity price in time t

$P_i^{max/min}$ Maximum/minimum power outputs of i -th thermal unit

$C_i(P_{i,t})$ Operating cost of thermal unit i (\$)

*Corresponding author

Email address: alireza.soroudi@gmail.com, Tel : (Office) +98(21) 66164324 Fax : +98(21) 66023261, Azadi Street, young researcher society, Tehran, Iran (Alireza Soroudi)

$U_{i,t}$ On/off status of unit i in time t

$\bar{\lambda}_t$ Predicted value of electricity price in time t

$ZS_{i,t}$ Shut down status of unit i in time t

$YS_{i,t}$ Start up status of unit i in time t

SD_i Shut down ramp rate of unit i

SU_i Start up ramp rate of unit i

$\bar{P}_{i,t}$ Upper operating power limit of thermal unit i in time t (MW)

TC Total operating cost of thermal units (\$)

PT_t Total generated power of the Genco in time t (MW)

UR_i, DR_i Up/Down ramp rate of i -th thermal unit MW/h

$\tilde{\lambda}_t$ Uncertain value of electricity price in time t

L_t^h Water level in the reservoir h in time t (million m^3)

I_t^h Water inflow into the reservoir h in time t (million m^3)

R_t^h Water released from the reservoir h in time t (million m^3)

S_t^h Water spillage from the reservoir h in time t (million m^3)

TE Total emission

1. Introduction

1.1. Motivation and Approach

The renewable energy sources have recently become an essential generation option for many countries to mitigate pollution and promote clean and sustainable energy development [1]. The volatility of output power in renewable energy resources can be compensated by using fast-acting dispatchable sources, like gas turbines or hydro power units [2] or both of them. The fast ramping and storage capabilities of cascaded hydro units [3] can be used for profit making in a deregulated power market environment. Different uncertainty resources have been identified for hydrothermal scheduling problem like load demand, reservoir water inflows, fuel price and

thermal unit forced unavailabilities, market price, random natural gas infrastructure interruptions [4, 5]. The existing models of the literature tried to model the aforementioned uncertainties using probabilistic approaches. One drawback of stochastic optimization technique is that they are computationally expensive and the decision maker needs to know the probability density function (PDF) of them. However, in some practical applications the computational burden becomes an important factor. On the other hand, the decision maker does not always have complete information about the distribution and behaviors of the uncertain parameters. The decision maker (Genco) needs some computational tools to be robust against the variation of uncertain input data which does not add complexity to the existing problem. The aim of this paper is to provide such a tool. The focus of this paper is just on modeling the uncertainty of price values in the day ahead electricity market.

1.2. Literature Review and Contributions

The hydro-thermal coordination problem is solved using different methods like Lagrangian multipliers correction procedure [6], clipping-off interior-point algorithm [7], coevolutionary algorithm (CEA) based on the Lagrangian method [8], bundle trust region method [9], diploid genotype based genetic algorithm [10], small population-based particle swarm optimization (SPPSO) approach [11], augmented Lagrangian approach [12], stochastic dual dynamic programming algorithm [13], benders decomposition approach [14, 15], stochastic midterm financial risk constrained [16], semidefinite programming [17], scenario simulation approach [18] and Monte Carlo based method [19].

1.3. Contributions

An optimal scheduling method for hydro-thermal plants is proposed without knowing the exact values or even probability distribution of hourly electricity prices. It incorporates the facilities that the smart grid technologies may provide for Gencos. The contributions of this work are summarized as follows:

- Modeling the uncertainties associated with price values without knowing the exact probability density function of them.
- Enhancement of the self-scheduling problem using smart grid facilities.

1.4. Paper Organization

This paper is set out as follows: section 2 presents problem formulation, the proposed robust optimization technique is presented in section 3. Simulation results are presented in section 4 and finally, section 5 summarizes the findings of this work.

2. Problem formulation

The assumptions and technical constraints considered in this work, are described as follows:

2.1. Uncertainty modeling of electricity price

The price of energy in electricity markets is determined by the behaviors of the market (including the generation and demand side) players. This would make this quantity very volatile. The literature suggests a wide range of methods for uncertainty modeling of electricity price such as scenario based modeling [20, 21], Monte Carlo approach [4], fuzzy arithmetic [22]. In this paper interval based uncertainty modeling [23] is used. The electricity price λ_t is assumed to be as follows:

$$\frac{|\tilde{\lambda}_t - \bar{\lambda}_t|}{\hat{\lambda}_t} \leq 1 \quad (1)$$

where $\bar{\lambda}_t$, $\hat{\lambda}_t$, $\tilde{\lambda}_t$ are the predicted value, maximum variation around the predicted value and uncertain real realization of the price quantity, respectively.

2.2. Total cost of energy production

The power production cost is defined as:

$$TC = \sum_{i,t} C_i(P_{i,t}) \quad (2)$$
$$C_i(P_{i,t}) = a_i(P_{i,t})^2 + b_i P_{i,t} + c_i * U_{i,t}$$

where a_i , b_i and c_i are the fuel cost coefficients of the i^{th} unit.

2.3. Thermal unit constraints

1. Technical constraints The output power change rate of the thermal unit must be in an acceptable range to avoid undue stresses on the boiler and combustion equipments. The ramp rate limits of generation units can be mathematically stated as follows [24]:

$$U_{i,t} = U_{i,t-1} + YS_{i,t} - ZS_{i,t} \quad (3)$$

$$P_{i,t} \leq \bar{P}_{i,t} \quad (4)$$

$$\bar{P}_{i,t} \leq (U_{i,t} - ZS_{i,t+1}) * P_i^{max} + ZS_{i,t} * SD_i \quad (5)$$

$$\bar{P}_{i,t} \leq P_{i,t-1} + U_{i,t-1} * UR_i + ZS_{i,t} * SU_i \quad (6)$$

$$\bar{P}_{i,t} \geq U_{i,t} * P_i^{min} \quad (7)$$

$$P_{i,t} \leq P_{i,t-1} + UR_i + P_i^{max} * U_{i,t} \quad (8)$$

$$P_{i,t-1} - P_{i,t} \leq U_{i,t} * DR_i + ZS_{i,t} * SD_i \quad (9)$$

where UR_i and DR_i are the ramp up/down limits of the i -th thermal unit (MW/h).

2. Emission allowance constraint The total emission of the Genco should be kept under the emission allowance limit, i.e. E_{max} as follows:

$$E_i(P_{i,t}) = d_i(P_{i,t})^2 + e_i P_{i,t} + f_i * U_{i,t} \quad (10)$$

$$TE = \sum_{i,t} E_i(P_{i,t}) \quad (11)$$

$$TE \leq E_{max} \quad (12)$$

2.4. Hydro unit constraints

2.4.1. Water Balance

The water balance equations that should be satisfied in each hour are:

$$\begin{aligned} L_{t+1}^h &= L_t^h + I_{t+1}^h - R_{t+1}^h - S_{t+1}^h \\ &\quad + \sum_{\hat{h}} [R_{t+1-\tau_{\hat{h}}}^{\hat{h}} + S_{t+1-\tau_{\hat{h}}}^{\hat{h}}] \\ L_{min}^h &\leq L_t^h \leq L_{max}^h, \hat{h} \in up \{h\} \\ R_t^h &\leq R_{max}^h, L_{t_0}^h = L_{ini}^h, L_{t_{24}}^h = L_{fin}^h \end{aligned} \quad (13)$$

where L_t^h is reservoir volume, I_{t+1}^h is the water inflow, R_{t+1}^h is the released water and S_{t+1}^h is the spilled water is at the end of period t in million m^3 . R_{max} is the maximum released capacity per hour in million m^3 . L_{start} is the volume of the water in dam at beginning of the considered horizon. This constraint means that the volume of water in a reservoir of hydro turbine h in time $t + 1$ will be equal to its value in the previous period plus the water inflow to its reservoir in time $t + 1$ minus its own released/spilled water and in time $t + 1$ plus the

released/spilled water of all reservoirs in its upstream in previous hours (with considering time delays $\tau_{\bar{h}}$). The concept of this cascade reservoir water balance constraint is depicted in Fig.1

2.4.2. Water to Power Conversion

The hydro power production function (HPF) (or hill chart [25]) which relates the output power of hydro plant to the water level, inflow and spillage [26] is of great importance in hydro plant scheduling. In this paper, the method proposed in [27, 11], has been adopted which describes the relationship between the released water and water level of the reservoir with the out put power of the hydro power plant, as follows:

$$P_{h,t} = c_1^h * L_t^h * L_t^h + c_2^h * R_t^h * R_t^h + c_3^h * R_t^h * L_t^h + c_4^h * L_t^h + c_5^h * R_t^h + c_6^h \quad (14)$$

where $c_{1 \rightarrow 6}^h$ are the characteristics factors of hydro turbine h . $P_{h,t}$ is the generated power of hydro unit h in time t .

2.5. Objective function

The objective function to be maximized is defined as the total money received from selling the energy minus the total paid costs as follows:

$$PT_t = \sum_h P_{h,t} + \sum_i P_{i,t} \quad (15)$$

$$OF = \sum_t PT_t * \tilde{\lambda}_t - TC \quad (16)$$

The values of hourly electricity price in (16) are subject to uncertainty. The uncertainty handling method is described in next section.

3. Proposed robust optimization approach

The concept of robust optimization (RO) was first introduced by Soyster [28]. It's a new approach to optimization problems affected by uncertainty specially in case of lack of full information on the nature of uncertainty [29]. The successful application of this method in power systems have been reported in recently published papers like: energy hub management [30], unit Commitment With Wind Power and Pumped Storage hydro [31], optimal adjustment of power system stabilizers [32], integration of plug-in hybrid electric vehicles (PHEVs) into the electric grid [33] and planning regional-scale electric power systems and managing carbon dioxide [34]. The concept of robust optimization is described as follows: consider a function like $z = f(x, y)$ which is linear with respect to x and non-linear with respect to y . The values of x are subject to uncertainty

while the y values are known. In robust optimization, it is assumed that no specified probability density function is in hand for describing the uncertain parameter x . The uncertainty of x is modeled with an uncertainty set $x \in U(x)$. Where $U(x)$ is a set that parameter x can take value from it. The maximization of $z = f(x, y)$ can be formulated as follows:

$$\max_y z = f(x, y) \quad (17)$$

$$x \in U(x) \quad (18)$$

Since the value of z is assumed to be linear with respect to x , it can be reformulated as follows:

$$\max_y z \quad (19)$$

$$z \leq f(x, y) \quad (20)$$

$$f(x, y) = A(y) * x + g(y) \quad (21)$$

$$x \in U(x) \quad (22)$$

The robust optimization seeks a solution which not only maximizes the objective function z but also insures the decision maker that if there exist some prediction error about the values of x , the z remains optimum with high probability [35]. To do this, a *robust counter part* version of the problem is constructed and solved. In this work, the uncertainty set $U(x)$ is defined as follows:

$$x \in U(x) = \{x \mid |x - \bar{x}| \leq \hat{x}\} \quad (23)$$

where \tilde{x} , \bar{x} , \hat{x} are the uncertain value, predicted value and maximum possible deviation of variable x from \hat{x} , respectively.

The robust counter part of problem stated in (19) is defined as follows:

$$\max_y z \quad (24)$$

$$z \leq f(x, z) \quad (25)$$

$$f(x, y) = A(y) * \bar{x} + g(y) - \max_{w_i} \sum_i a_i(y) * \hat{x}_i * w_i \quad (26)$$

$$\sum_i w_i \leq \Gamma \quad (27)$$

$$0 \leq w_i \leq 1 \quad (28)$$

As it is concluded from (24), there are two nested optimization problems. Consider the following optimization:

$$\max_{w_i} \left(a_1(y) * \hat{x}_1 \quad a_2(y) * \hat{x}_2 \quad \cdots \quad a_n(y) * \hat{x}_n \right) \begin{pmatrix} w_1 \\ w_2 \\ \vdots \\ w_n \end{pmatrix} \quad (29)$$

$$\begin{pmatrix} 1 & 1 & \cdots & 1 \\ 1 & 0 & \cdots & 0 \\ 0 & 1 & \cdots & 0 \\ \vdots & \vdots & \ddots & \vdots \\ 0 & 0 & \cdots & 1 \end{pmatrix} \begin{pmatrix} w_1 \\ w_2 \\ \vdots \\ w_n \end{pmatrix} \leq \begin{pmatrix} \Gamma \\ 1 \\ 1 \\ \vdots \\ 1 \end{pmatrix} \quad (30)$$

This is linear with respect to w_i and has a dual form as follows:

$$\begin{aligned} \min_{\xi_i, \beta} \Gamma\beta + \sum_i \xi_i & \quad (31) \\ \beta + \xi_i & \geq a_i(y) * \hat{x}_i \end{aligned}$$

Inserting the (31) into (24) gives :

$$\max_{y, \xi_i, \beta} z \quad (32)$$

$$z \leq f(x, z) \quad (33)$$

$$f(x, y) = A(y) * \bar{x} + g(y) - \Gamma\beta - \sum_i \xi_i \quad (34)$$

$$\beta + \xi_i \geq A(y_i) * \hat{x}_i \quad (35)$$

3.1. Scheduling without smart grid

The Genco tries to maximize its benefit considering that the price values in Γ percent of hours of the upcoming day are unknown.

$$\max_{P_{i,t}, P_{h,t}} OF = \sum_t PT_t * \tilde{\lambda}_t - TC \quad (36)$$

Subject to:

Constraints: (2) \rightarrow (15)

This is equivalent to the following formulation:

$$\max_{P_{i,t}, P_{h,t}} z \quad (37)$$

Subject to:

$$z \leq \sum_t PT_t * \tilde{\lambda}_t - TC$$

Constraints: (2) \rightarrow (15)

Since it should remain feasible at presence of any disturbance in uncertain values of price, then the robust counter part of the problem is constructed as follows:

$$\max_{P_{i,t}, P_{h,t}} z \quad (38)$$

$$z \leq \sum_t PT_t * \bar{\lambda}_t - TC - \max_{w_t} \sum_t (PT_t)^* * \hat{\lambda}_t * w_t \quad (39)$$

$$\sum_t w_t \leq \Gamma \quad (40)$$

$$w_t \leq 1 \quad (41)$$

Constraints: (2) \rightarrow (15)

where $(PT_t)^*$ is the optimal value of the problem without considering the uncertainties. Γ is called the budget of uncertainty. This is a control parameter set by decision maker to specify his degree of conservativeness. The value of Γ indicates that the price values in how many hours may deviate its predicted values $\bar{\lambda}_t$.

Using the method proposed in [35] the robust counterpart of the problem is described as follows:

$$\max_{\beta, \xi_t, P_{i,t}, P_{h,t}} z \quad (42)$$

Subject to:

$$z \leq \sum_t PT_t * \bar{\lambda}_t - \Gamma * \beta - \sum_t \xi_t - TC \quad (43)$$

$$\beta + \xi_t \geq PT_t * \hat{\lambda}_t \quad (44)$$

Constraints: (2) \rightarrow (15)

In this formulation, the $\beta, \xi_t, P_{i,t}, P_{h,t}$ constitute the decision variable vectors. It should be noted that the β, ξ_t are dual variables of the original problem (38).

3.2. Scheduling with smart grid

By applying the smart grid concept, the Genco can expect higher benefits since he has more information about the price values (the price up to time t as depicted in Fig.2). This would work in the following way:

assuming that the market is cleared based on day ahead operation, the actual price values are known by the ISO and the information of actual price values are transmitted to the Gencos 10 minutes prior to the beginning of hour t using the scheme depicted in Fig.3. In this way the Genco would be aware of all price values up to time t . This moving window rolls from $t = 1$ and ends to $t = 24$. At the beginning of the day the only available quantity is the actual value of price in $t = 1$ and the length of the aforementioned window is $24 - 1$ hours. In the next hour the actual values of $t = 1, 2$ are know and the length of the rolling window is $24 - 2$ hours for decision making about the generating schedule. In hour t , the values of price are known for hours $1 \rightarrow t$ so the length of the decision making window is $24 - t$. In this way, the Genco is able to adjust its operating schedule decisions for time t to 24 when it reaches to hour t . This is the key point of getting equipped with smart grid facilities.

The steps of the proposed algorithm are as follows:

Step.1 : set $\acute{t} = 1$

Step.2 : solve the following optimization

$$\max_{\beta, \xi_t, P_{i,t}, P_{h,t}} z \quad (45)$$

Subject to:

$$z \leq \sum_t PT_t * \tilde{\lambda}_t - \Gamma * \beta - \sum_t \xi_t - TC \quad (46)$$

$$\tilde{\lambda}_t = \bar{\lambda}_t \text{ for } t > \acute{t} \quad (47)$$

$$\tilde{\lambda}_t = \lambda_t^a \text{ for } t \leq \acute{t} \quad (48)$$

$$\beta + \xi_t \geq PT_t * \hat{\lambda}_t \quad (49)$$

Constraints: (2) \rightarrow (15)

Step.3 : fix the values of $P_{i,\acute{t}}, P_{h,\acute{t}}$

Step.4 : $\acute{t} = \acute{t} + 1$

Step.5 : if $\acute{t} \leq 24$ go to Step 2; else continue.

Step.6 : Stop

4. Simulation results

The proposed approach is implemented in GAMS[36] environment and solved by CONOPT solver [37]. It is applied on a 11-thermal units system [38] and 4 cascaded hydro units as described in Table 1. The values of

electricity price are given in Table 2 [23]. The upper and lower bounds of price values along with the actual (which would be revealed after the upcoming day) and predicted values of them are depicted in Fig.4.

The reservoir inflows and predicted values of electricity prices are available in Table 3 [27]. The technical characteristics of hydro units are given in Table 4 [27].

In the case “without Smart Grid”, the value of Γ are interpreted as follows: in Γ percent of the 24 hours of the upcoming day, the actual values of price may be different with the predicted values of them. In the case “with Smart Grid”, the value of Γ have different meanings as follows: the actual values of price quantities are known up to time t . In Γ percent of the hours between $t + 1$ to 24 of the upcoming day, the actual values of price may be different with the predicted values of them. The problem is first solved when the emission constraint is relaxed and then the impact of this constraint is investigated as described in the following sections.

4.1. Case A: no emission limit

In this case the value of E_{max} is set to ∞ . Two cases are studied, namely: decision making with and without smart grid technology. The values of total benefits of Genco for both cases are given in Table 5. The first column in Table 5 shows the budget of uncertainty (Γ) which is changed from 0 to 100 %. It can be concluded from the values of Table 5 that the corporation of smart grid facilities can bring some benefits for the Gencos as they may have more information about the future values of the uncertain parameters like electricity prices. The values of Table 5 show that if the degree of conservatism (Γ) is increased then the benefit decreases. In other words, if the decision maker tries to hedge himself from the risk of low level prices then he will be getting far from the optimality (high benefits). In fact there is always a trade off between the robustness and the optimality of solutions. The total generated powers for both aforementioned cases are shown in Fig. 5. This shows that for a given level of conservativeness, the total generated power of Genco is less in no smart grid case. For $\Gamma = 0, 80, 100\%$ the values of scheduled power in both thermal and hydro plants are given in Tables 6,7,8, respectively.

4.2. Case B: with emission limit

In this case the optimal self scheduling problem is solved for various values of E_{max} . The emission limit is varied from 100 to 10 Tons of NO_x . The optimal values of total benefits for both cases (with smart grid and without smart grid) are given in Table 9. As it is expected, if the emission limit constraint is imposed, the total benefits of the Genco decreases. However in all cases the use of smart grid technology can increase the net benefits of the Genco compared with the case when no smart grid is available.

5. Conclusion

This paper formulates a robust optimization based self scheduling algorithm for hydro-thermal units. The uncertainty of electricity prices of power market is taken into account using a polyhedral uncertainty set and solved by a robust optimization technique. The impacts of smart grid and emission allowance have been investigated. This practical tool can be used by a Genco for maximizing his payoffs in competitive power markets where the price values are uncertain due to the behaviors of other price maker Gencos. The proposed method does not need any PDF or membership function of uncertain price values and uses an interval for describing the uncertainty. The low computational burden of the procedure makes it suitable for real-time applications. It is shown that using the proposed approach would increase the payoffs of a Genco specially when used in smart grids. Future works may include, modeling other uncertain parameters modeling which affects the scheduling decisions. The proposed methodology presented in this work can serve as a basis for this purpose.

References

- [1] A. Street, L. Barroso, B. Flach, M. Pereira, S. Granville, Risk constrained portfolio selection of renewable sources in hydrothermal electricity markets, *IEEE Trans. on Power Sys.* 24 (3) (2009) 1136 –1144.
- [2] T. Brekken, A. Yokochi, A. von Jouanne, Z. Yen, H. Hapke, D. Halamay, Optimal energy storage sizing and control for wind power applications, *IEEE Trans. on Sust. Energy*, 2 (1) (2011) 69 –77.
- [3] L. V. L. Abreu, M. E. Khodayar, M. Shahidehpour, L. Wu, Risk-constrained coordination of cascaded hydro units with variable wind power generation, *IEEE Trans. on Sust. Energy*, 3 (3) (2012) 359 –368.
- [4] C. Sahin, Z. Li, M. Shahidehpour, I. Erkmén, Impact of natural gas system on risk-constrained midterm hydrothermal scheduling, *IEEE Trans. on Power Sys.* 26 (2) (2011) 520 –531.
- [5] J. Cabero, A. Baillo, S. Cerisola, M. Ventosa, A. Garcia-Alcalde, F. Peran, G. Relano, A medium-term integrated risk management model for a hydrothermal generation company, *IEEE Trans. on Power Sys.* 20 (3) (2005) 1379 – 1388.
- [6] S. Ruzic, R. Rajakovic, Optimal distance method for lagrangian multipliers updating in short-term hydro-thermal coordination, *IEEE Trans. on Power Sys.* 13 (4) (1998) 1439 –1444.
- [7] J. Medina, V. Quintana, A. Conejo, A clipping-off interior-point technique for medium-term hydro-thermal coordination, *IEEE Trans. on Power Sys.* 14 (1) (1999) 266 –273.

- [8] R.-H. Liang, M.-H. Ke, Y.-T. Chen, Coevolutionary algorithm based on lagrangian method for hydrothermal generation scheduling, *IEEE Trans. on Power Sys.* 24 (2) (2009) 499 –507.
- [9] D. Zhang, P. Luh, Y. Zhang, A bundle method for hydrothermal scheduling, *IEEE Trans. on Power Sys.* 14 (4) (1999) 1355 –1361.
- [10] Y.-G. Wu, C.-Y. Ho, D.-Y. Wang, A diploid genetic approach to short-term scheduling of hydro-thermal system, *IEEE Trans. on Power Sys.* 15 (4) (2000) 1268 –1274.
- [11] J. Zhang, J. Wang, C. Yue, Small population-based particle swarm optimization for short-term hydrothermal scheduling, *IEEE Trans. on Power Sys.* 27 (1) (2012) 142 –152.
- [12] S. Al-Agtash, R. Su, Augmented lagrangian approach to hydro-thermal scheduling, *IEEE Trans. on Power Sys.* 13 (4) (1998) 1392 –1400.
- [13] S. Rebennack, B. Flach, M. V. F. Pereira, P. M. Pardalos, Stochastic hydro-thermal scheduling under co2 emissions constraints, *IEEE Trans. on Power Sys.* 27 (1) (2012) 58 –68.
- [14] T. Norbiato dos Santos, A. Diniz, A new multiperiod stage definition for the multistage benders decomposition approach applied to hydrothermal scheduling, *IEEE Trans. on Power Sys.* 24 (3) (2009) 1383 –1392.
- [15] W. Sifuentes, A. Vargas, Hydrothermal scheduling using benders decomposition: Accelerating techniques, *IEEE Trans. on Power Sys.* 22 (3) (2007) 1351 –1359.
- [16] L. Wu, M. Shahidehpour, Z. Li, Genco's risk-constrained hydrothermal scheduling, *IEEE Trans. on Power Sys.* 23 (4) (2008) 1847 –1858.
- [17] R. Fuentes-Loyola, V. Quintana, Medium-term hydrothermal coordination by semidefinite programming, *IEEE Trans. on Power Sys.* 18 (4) (2003) 1515 – 1522.
- [18] L. Vargas, P. Rodrigo, M. Oscar, T. Rigoberto, A scenario simulation approach for market power analysis in hydrothermal systems, *IEEE Trans. on Power Sys.* 18 (3) (2003) 1046 – 1053.
- [19] C. Baslis, S. Papadakis, A. Bakirtzis, Simulation of optimal medium-term hydro-thermal system operation by grid computing, *IEEE Trans. on Power Sys.* 24 (3) (2009) 1208 –1217.
- [20] R. Jabr, Robust self-scheduling under price uncertainty using conditional value-at-risk, *IEEE Trans. on Power Sys.* 20 (4) (2005) 1852 – 1858.

- [21] S. Kazempour, A. Conejo, C. Ruiz, Strategic generation investment using a complementarity approach, *IEEE Trans. on Power Sys.* 26 (2) (2011) 940 –948.
- [22] H. Yamin, Fuzzy self-scheduling for gencos, *IEEE Trans. on Power Sys.* 20 (1) (2005) 503 – 505.
- [23] A. Conejo, J. Morales, L. Baringo, Real-time demand response model, *Smart Grid, IEEE Transactions on* 1 (3) (2010) 236 –242.
- [24] B. Mohammadi-Ivatloo, A. Rabiee, A. Soroudi, M. Ehsan, Iteration pso with time varying acceleration coefficients for solving non-convex economic dispatch problems, *Int. Journal of Elec. Power & Energy Sys.* 42 (1) (2012) 508 – 516.
- [25] A. Conejo, J. Arroyo, J. Contreras, F. Villamor, Self-scheduling of a hydro producer in a pool-based electricity market, *IEEE Trans. on Power Sys.* 17 (4) (2002) 1265 – 1272.
- [26] A. Diniz, M. Maceira, A four-dimensional model of hydro generation for the short-term hydrothermal dispatch problem considering head and spillage effects, *IEEE Trans. on Power Sys.* 23 (3) (2008) 1298 –1308.
- [27] M. Basu, An interactive fuzzy satisfying method based on evolutionary programming technique for multiobjective short-term hydrothermal scheduling, *Electric Power Systems Research* 69 (23) (2004) 277 – 285.
- [28] A. L. Soyster, Convex programming with set-inclusive constraints and applications to inexact linear programming, *Journal of Operations Research* 21 (2) (1973) 1154–1157.
- [29] A. Ben-Tal, L. E. Ghaoui, A. Nemirovski, *Robust Optimization*, 1st Edition, Princeton Series in Applied Mathematics, 2009.
- [30] A. Parisio, C. D. Vecchio, A. Vaccaro, A robust optimization approach to energy hub management, *Int. Journal of Elec. Power & Energy Sys.* 42 (1) (2012) 98 – 104.
- [31] R. Jiang, J. Wang, Y. Guan, Robust unit commitment with wind power and pumped storage hydro, *IEEE Trans. on Power Sys.* PP (99) (2011) 1.
- [32] V. de Campos, J. da Cruz, L. Z. Jr., Robust and optimal adjustment of power system stabilizers through linear matrix inequalities, *Int. Journal of Elec. Power & Energy Sys.* 42 (1) (2012) 478 – 486.

- [33] A. Hajimiragha, C. Canizares, M. Fowler, S. Moazeni, A. Elkamel, A robust optimization approach for planning the transition to plug-in hybrid electric vehicles, *IEEE Trans. on Power Sys.* 26 (4) (2011) 2264–2274.
- [34] C. Chen, Y. Li, G. Huang, Y. Li, A robust optimization method for planning regional-scale electric power systems and managing carbon dioxide, *Int. Journal of Elec. Power & Energy Sys.* 40 (1) (2012) 70 – 84.
- [35] D. Bertsimas, M. Sim, The price of robustness, *Journal of Operations Research* 52 (1) (2004) 35–53.
- [36] 'GAMS', A user guide, Tech. rep., New York (2008).
- [37] Solver, www.gams.com/dd/docs/solvers/conopt.pdf, Accessed on May, 2012.
- [38] C. Palanichamy, N. Babu, Day-night weather-based economic power dispatch, *IEEE Transactions on Power Systems* 17 (2) (2002) 469 –475.

List of figure captions:

F1g.1 . The concept of cascaded reservoirs

F2g.2 . The concept of smart grid

F3g.3 . The communication scheme of smart grid used for reducing the uncertainty of price values

F4g.4 . The price values

F5g.5 . The comparison between the total generated power in both smart grid and without smart grid versus the budget of uncertainty Γ

Table 1: The characteristics of Thermal power generators

i	$a_i(\$/MWh^2)$	$b_i(\$/MWh)$	$c_i(\$ RU_i(MW/h))$	$SD_i, RD_i(MW/h)$	$SU_i, RU_i(MW/h)$
1	0.00762	1.92699	387.85	50	50
2	0.00838	2.11969	441.62	42	42
3	0.00523	2.19196	422.57	50	50
4	0.00140	2.01983	552.50	60	60
5	0.00154	2.22181	557.75	42	42
6	0.00177	1.91528	562.18	60	60
7	0.00195	2.10681	568.39	43	43
8	0.00106	1.99138	682.93	91	91
9	0.00117	1.99802	741.22	91	91
10	0.00089	2.12352	617.83	92	92
11	0.00098	2.10487	674.61	93	93
i	$(d_i kgNO_x/MWh^2)$	$e_i kgNO_x/MWh$	$f_i kgNO_x$	$P_i^{min}(MW)$	$P_i^{max}(MW)$
1	0.00419	-0.67767	33.93	20	250
2	0.00461	-0.69044	24.62	20	210
3	0.00419	-0.67767	33.93	20	250
4	0.00683	-0.54551	27.14	60	300
5	0.00751	-0.40006	24.15	20	210
6	0.00683	-0.54551	27.14	60	300
7	0.00751	-0.40006	24.15	20	215
8	0.00355	-0.51116	30.45	100	455
9	0.00417	-0.56228	25.59	100	455
10	0.00355	-0.41116	30.45	110	460
11	0.00417	-0.56228	25.59	110	465

Table 2: The actual and predicted interval for price values

Hour	λ_t^a	$\bar{\lambda}_t$	$\hat{\lambda}_t$
t_1	44.80	45.72	6.72
t_2	41.03	41.63	8.27
t_3	36.10	36.29	8.65
t_4	33.00	32.65	8.60
t_5	33.00	31.20	8.61
t_6	36.46	32.51	9.26
t_7	43.01	39.07	11.34
t_8	47.05	43.53	12.76
t_9	46.06	43.63	12.88
t_{10}	45.51	44.82	13.29
t_{11}	46.06	46.41	13.80
t_{12}	44.50	45.66	13.60
t_{13}	45.61	46.78	13.95
t_{14}	45.42	46.28	13.81
t_{15}	39.28	45.02	13.44
t_{16}	41.16	46.20	13.79
t_{17}	42.01	46.17	13.79
t_{18}	43.00	46.03	13.75
t_{19}	41.16	45.13	13.48
t_{20}	41.63	43.83	13.09
t_{21}	42.00	42.31	12.64
t_{22}	41.16	41.77	12.48
t_{23}	41.87	43.03	12.85
t_{24}	36.81	41.12	12.29

Table 3: The values of water inflow over the hours

Period	<i>Reservoir</i> _{1,t}	<i>Reservoir</i> _{2,t}	<i>Reservoir</i> _{3,t}	<i>Reservoir</i> _{4,t}
t_1	10	8	8.10	2.80
t_2	9	8	8.20	2.40
t_3	8	9	4.00	1.60
t_4	7	9	2.00	0
t_5	6	8	3.00	0
t_6	7	7	4.00	0
t_7	8	6	3.00	0
t_8	9	7	2.00	0
t_9	10	8	1.00	0
t_{10}	11	9	1.00	0
t_{11}	12	9	1.00	0
t_{12}	10	8	2.00	0
t_{13}	11	8	4	0
t_{14}	12	9	3	0
t_{15}	11	9	3	0
t_{16}	10	8	2	0
t_{17}	9	7	2	0
t_{18}	8	6	2	0
t_{19}	7	7	1	0
t_{20}	6	8	1	0
t_{21}	7	9	2	0
t_{22}	8	9	2	0
t_{23}	9	8	1	0
t_{24}	10	8	0	0

Table 4: The characteristics of hydro power generators

h	L_{min}^h	L_{max}^h	L_{ini}^h	L_{fin}^h	R_{min}^h	R_{max}^h	P_h^{min}	P_h^{max}
1	80	150	100	120	5	15	0	500
2	60	120	80	70	6	15	0	500
3	100	240	170	170	10	30	0	500
4	70	160	120	140	6	20	0	500
h	c_1^h	c_2^h	c_3^h	c_4^h	c_5^h	c_6^h	τ_h	(h)
1	-0.0042	-0.42	0.03	0.9	10	-50	2	
2	-0.004	-0.3	0.015	1.14	9.5	-70	3	
3	-0.0016	-0.3	0.014	0.55	5.5	-40	4	
4	-0.003	-0.31	0.027	1.44	14	-90	0	

Table 5: The comparison between the benefits and emissions of decision making with and without smart grid (the values are in \$)

Γ (%)	Benefits (\$)		NO_x (Kg)	
	With SG	Without SG	With SG	Without SG
0	3512090.203	3463784.48	93781.07085	93780.98956
10	3512090.532	3340178.74	93780.98956	93778.93794
20	3512032.528	3216610.82	93778.93794	93772.40709
30	3512032.528	3093084.90	93778.93794	93756.96448
40	3512032.050	2969655.66	93779.05313	93756.96448
50	3511877.584	2846354.82	93772.74384	93720.22620
60	3511753.528	2723148.95	93769.42886	93702.77822
70	3511681.643	2599998.40	93766.83028	93702.77822
80	3511492.612	2478325.08	93758.38598	93294.58903
90	3511487.719	2357201.13	93760.28632	93122.45837
100	3511214.850	2236505.06	93752.38952	92922.39015

Table 6: The total generated MW in each hour in case $\Gamma = 0\%$

hour	With Smart Grid		Without Smart Grid	
	Total Thermal	Total Hydro	Total Thermal	Total Hydro
t_1	1354.00	483.63	1354.00	483.63
t_2	2068.00	480.40	2068.00	480.40
t_3	2782.00	471.61	2782.00	471.61
t_4	3443.00	461.97	3443.00	461.97
t_5	3570.00	484.16	3569.93	484.23
t_6	3570.00	492.44	3570.00	492.44
t_7	3570.00	502.95	3570.00	502.95
t_8	3570.00	508.31	3570.00	508.31
t_9	3570.00	509.18	3570.00	509.18
t_{10}	3570.00	511.17	3570.00	511.17
t_{11}	3570.00	518.58	3570.00	518.58
t_{12}	3570.00	519.45	3570.00	519.45
t_{13}	3570.00	527.01	3570.00	527.01
t_{14}	3570.00	531.31	3570.00	531.31
t_{15}	3570.00	521.77	3570.00	521.77
t_{16}	3570.00	531.51	3570.00	531.51
t_{17}	3570.00	535.90	3570.00	535.90
t_{18}	3570.00	538.48	3570.00	538.48
t_{19}	3570.00	536.27	3570.00	536.27
t_{20}	3570.00	539.00	3570.00	539.00
t_{21}	3570.00	540.94	3570.00	540.94
t_{22}	3570.00	540.87	3570.00	540.87
t_{23}	3570.00	542.05	3570.00	542.05
t_{24}	3570.00	513.65	3570.00	513.65

Table 7: The total generated MW in each hour in case $\Gamma = 80\%$

hour	With Smart Grid		Without Smart Grid	
	Total Thermal	Total Hydro	Total Thermal	Total Hydro
t_1	1354.00	490.91	1354.00	490.91
t_2	2068.00	487.66	2068.00	487.66
t_3	2782.00	479.99	2782.00	479.99
t_4	3443.00	472.08	3443.00	472.08
t_5	3570.00	494.20	3570.00	494.20
t_6	3570.00	500.17	3570.00	500.17
t_7	3570.00	512.46	3570.00	512.46
t_8	3570.00	522.49	3570.00	522.49
t_9	3570.00	521.48	3570.00	521.48
t_{10}	3570.00	497.25	3570.00	497.25
t_{11}	3570.00	501.80	3570.00	501.80
t_{12}	3570.00	502.14	3570.00	502.14
t_{13}	3570.00	511.75	3570.00	511.75
t_{14}	3570.00	518.54	3570.00	518.54
t_{15}	3570.00	500.68	3569.87	500.82
t_{16}	3570.00	517.15	3570.00	517.15
t_{17}	3570.00	524.26	3570.00	524.26
t_{18}	3570.00	529.02	3570.00	529.02
t_{19}	3570.00	526.33	3570.00	526.33
t_{20}	3570.00	533.04	3570.00	533.04
t_{21}	3570.00	554.98	3570.00	554.98
t_{22}	3570.00	552.57	3570.00	552.57
t_{23}	3570.00	544.31	3570.00	544.31
t_{24}	3570.00	520.55	3570.00	520.55

Table 8: The total generated MW in each hour in case $\Gamma = 100\%$

hour	With Smart Grid		Without Smart Grid	
	Total Thermal	Total Hydro	Total Thermal	Total Hydro
t_1	1354.00	495.09	1354.00	495.09
t_2	2068.00	492.03	2068.00	492.03
t_3	2782.00	484.48	2782.00	484.48
t_4	3443.00	475.39	3443.00	475.39
t_5	3570.00	495.95	3570.00	495.95
t_6	3570.00	500.41	3570.00	500.41
t_7	3570.00	512.64	3570.00	512.64
t_8	3570.00	497.74	3570.00	497.74
t_9	3570.00	499.25	3570.00	499.25
t_{10}	3570.00	501.78	3570.00	501.78
t_{11}	3570.00	508.61	3570.00	508.61
t_{12}	3570.00	509.94	3570.00	509.94
t_{13}	3570.00	519.36	3570.00	519.36
t_{14}	3570.00	525.14	3570.00	525.14
t_{15}	3570.00	508.84	3564.46	514.38
t_{16}	3570.00	523.36	3570.00	523.36
t_{17}	3570.00	530.56	3570.00	530.56
t_{18}	3570.00	535.30	3570.00	535.30
t_{19}	3570.00	532.63	3570.00	532.63
t_{20}	3570.00	537.37	3570.00	536.36
t_{21}	3570.00	540.31	3570.00	539.09
t_{22}	3570.00	540.36	3570.00	539.13
t_{23}	3570.00	540.42	3570.00	539.22
t_{24}	3570.00	521.79	3570.00	521.79

Table 9: The total benefits of Genco for different emission allowances: in smart grid (smartB) and non-smart grid (NsmartB) environment

$E_{\max}(kgNO_x) \rightarrow$	100000		90000		80000		70000		60000	
Γ	smartB (\$)	NsmartB (\$)	smartB (\$)	NsmartB (\$)	smartB (\$)	NsmartB (\$)	smartB (\$)	NsmartB (\$)	smartB (\$)	NsmartB (\$)
0	3512090.20	3463784.48	3472265.95	3425186.27	3346729.03	3301194.64	3204641.26	3160205.33	3047503.94	3005289.57
0.10	3512090.53	3340178.74	3472270.65	3302406.52	3346734.88	3182693.26	3204647.04	3046604.86	3047508.12	2897610.45
0.20	3512032.53	3216610.82	3472270.48	3179626.82	3346734.88	3064192.61	3204647.04	2933004.39	3047508.32	2789931.33
0.30	3512032.53	3093084.90	3472269.36	3056850.92	3346731.51	2945709.86	3204647.04	2819404.79	3047507.22	2682255.28
0.40	3512032.05	2969655.66	3472262.89	2934081.27	3346673.16	2827274.43	3204645.94	2705909.84	3047467.68	2574740.61
0.50	3511877.58	2846354.82	3472226.98	2811326.59	3346378.86	2709128.65	3203998.31	2592810.23	3046709.95	2467587.39
0.60	3511753.53	2723148.95	3472179.34	2688855.64	3345370.23	2591450.69	3203055.70	2480135.46	3046103.28	2360829.02
0.70	3511681.64	2599998.40	3471377.99	2566763.35	3345116.06	2474080.04	3202634.38	2367971.06	3045770.87	2254532.14
0.80	3511492.61	2478325.08	3470482.39	2445630.42	3344055.46	2356842.11	3202075.68	2256514.44	3045124.96	2148747.27
0.90	3511487.72	2357201.13	3469695.88	2325423.09	3343851.53	2241357.59	3201444.24	2145619.79	2726507.68	2043571.70
1.00	3511214.85	2236505.06	3468577.88	2205938.13	3343298.42	2126130.23	3200303.04	2035536.05	3043705.53	1939080.82
$E_{\max}(kgNO_x) \rightarrow$	50000		40000		30000		20000		10000	
Γ	smartB (\$)	NsmartB (\$)	smartB (\$)	NsmartB (\$)	smartB (\$)	NsmartB (\$)	smartB (\$)	NsmartB (\$)	smartB (\$)	NsmartB (\$)
0	2872630.04	2833368.75	2672964.99	2636952.78	2435333.28	2403034.72	2137199.49	2109190.63	1719626.89	1697459.36
0.1	2872636.97	2732130.52	2672974.06	2542916.72	2435331.74	2317257.55	2137195.16	2034194.71	1719633.06	1637040.64
0.2	2872636.85	2630893.99	2672958.16	2448893.17	2435281.27	2231572.83	2137143.20	1959291.39	1719616.63	1576638.55
0.3	2872617.46	2529674.42	2672908.38	2354917.90	2435145.76	2146065.40	2137040.61	1884450.81	1719600.82	1516268.84
0.4	2872518.58	2428701.88	2672703.15	2261329.08	2434942.39	2060673.38	2136895.09	1809766.67	1719548.76	1455975.37
0.5	2871719.49	2328014.14	2672178.61	2167868.22	2434590.97	1975430.16	2136808.78	1735180.38	1719429.17	1395898.14
0.6	2871448.71	2227546.88	2672082.62	2074463.21	2434524.82	1890624.73	2136549.11	1660900.06	1719176.67	1335939.98
0.7	2871116.64	2127760.71	2671215.21	1982029.49	2434023.19	1806291.29	2136095.14	1587010.22	1718883.50	1276139.96
0.8	2870307.13	2028456.18	2670706.02	1889809.69	2433471.80	1722282.43	2135768.66	1513312.58	1718465.07	1216481.19
0.9	2869950.40	1929322.69	2670601.10	1797752.68	2432876.64	1638518.39	2135121.36	1439777.50	1717835.86	1157529.64
1	2868932.09	1831253.52	2670266.99	1706657.71	2431579.50	1555332.41	2134213.65	1366946.09	1717469.77	1098650.55

Table 10: The total CPU time (seconds) for different emission allowances: in smart grid (smartB) and non-smart grid (NsmartB) environment

$E_{\max}(kgNO_x) \rightarrow$	100000		90000		80000		70000		60000	
Γ	smartB	NsmartB	smartB	NsmartB	smartB	NsmartB	smartB	NsmartB	smartB	NsmartB
0	4.670	4.665	4.691	4.688	4.734	4.719	4.762	4.747	4.783	4.770
0.1	4.702	4.691	4.742	4.729	4.745	4.739	4.797	4.785	4.835	4.821
0.2	4.740	4.720	4.734	4.721	4.774	4.755	4.779	4.777	4.796	4.790
0.3	4.667	4.650	4.699	4.680	4.744	4.726	4.769	4.763	4.816	4.810
0.4	4.657	4.655	4.710	4.701	4.720	4.720	4.780	4.770	4.823	4.811
0.5	4.770	4.766	4.774	4.773	4.789	4.775	4.824	4.808	4.822	4.817
0.6	4.776	4.773	4.792	4.781	4.789	4.788	4.816	4.801	4.812	4.811
0.7	4.737	4.724	4.766	4.763	4.814	4.803	4.835	4.818	4.835	4.818
0.8	4.761	4.749	4.795	4.790	4.854	4.837	4.870	4.852	4.893	4.884
0.9	4.767	4.758	4.790	4.774	4.799	4.794	4.840	4.822	4.858	4.855
1	4.843	4.825	4.847	4.846	4.855	4.848	4.885	4.883	4.913	4.907
$E_{\max}(kgNO_x) \rightarrow$	50000		40000		30000		20000		10000	
Γ	smartB	NsmartB	smartB	NsmartB	smartB	NsmartB	smartB	NsmartB	smartB	NsmartB
0	4.761	4.748	4.803	4.786	4.838	4.824	4.835	4.826	4.871	4.853
0.1	4.800	4.796	4.827	4.810	4.863	4.858	4.894	4.885	4.927	4.901
0.2	4.812	4.810	4.855	4.852	4.878	4.863	4.886	4.872	4.949	4.904
0.3	4.859	4.852	4.878	4.865	4.903	4.884	4.908	4.906	4.956	4.920
0.4	4.832	4.830	4.887	4.868	4.914	4.909	4.922	4.912	4.954	4.948
0.5	4.871	4.860	4.895	4.882	4.927	4.927	4.951	4.948	4.975	4.960
0.6	4.823	4.811	4.854	4.844	4.902	4.888	4.944	4.925	5.004	4.969
0.7	4.911	4.908	4.962	4.943	4.949	4.945	4.971	4.962	5.031	4.988
0.8	4.939	4.935	4.961	4.941	4.948	4.946	4.999	4.985	5.052	5.006
0.9	4.940	4.932	4.971	4.967	4.990	4.981	5.000	4.989	5.040	5.010
1	4.942	4.930	4.937	4.937	4.947	4.942	4.993	4.977	5.037	5.012

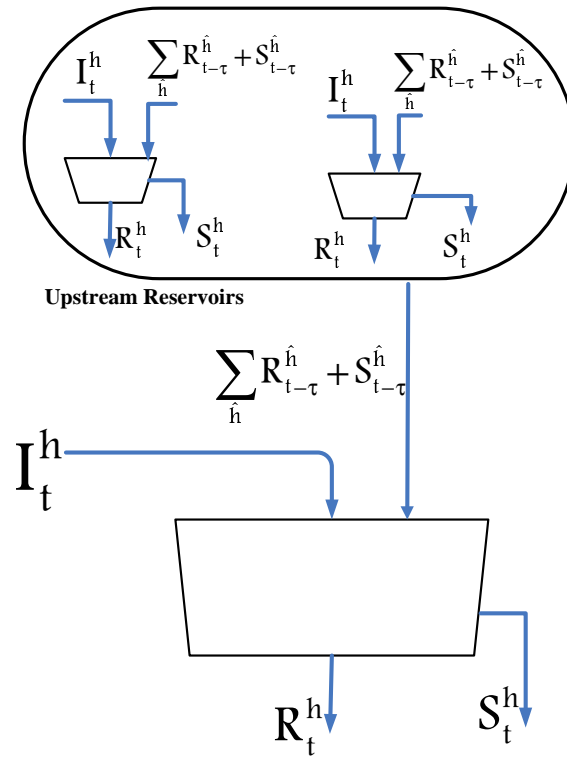

Figure 1: The concept of cascaded reservoirs

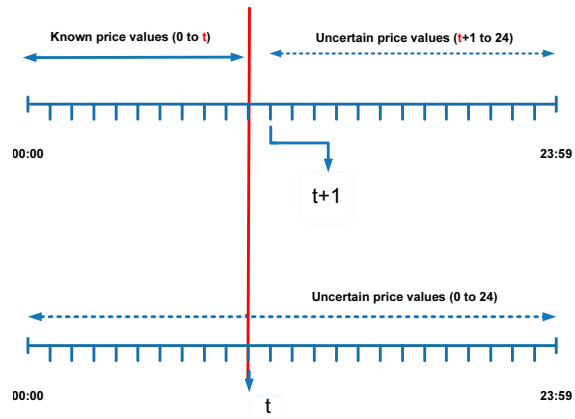

Figure 2: The concept of smart grid

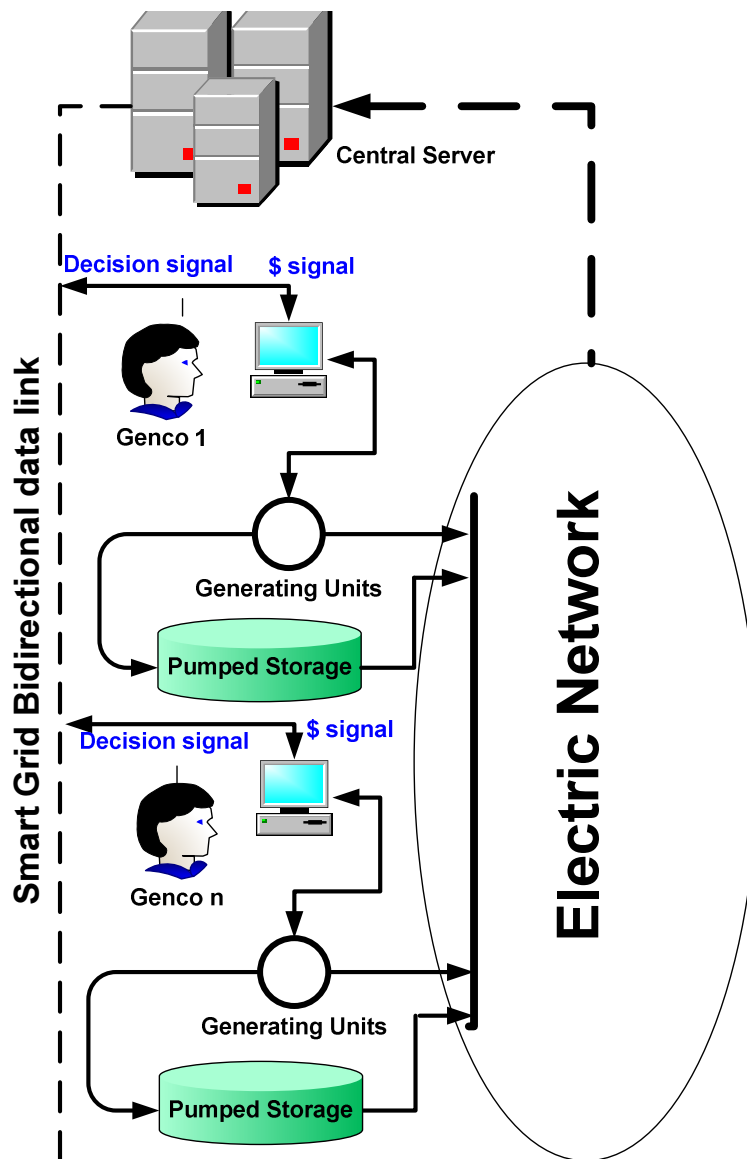

Figure 3: The communication scheme of smart grid used for reducing the uncertainty of price values

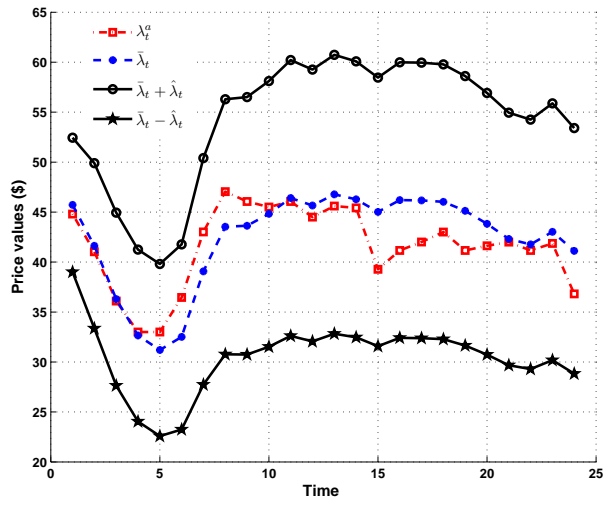

Figure 4: The price values

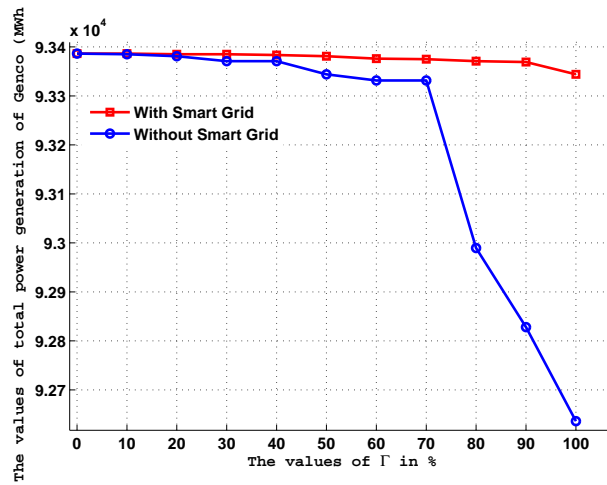

Figure 5: The comparison between the total generated power in both smart grid and without smart grid versus the budget of uncertainty Γ