



Title	Stochastic Transient Stability Analysis of Transmission Systems With Inclusion of Energy Storage Devices
Authors(s)	Ortega, Alvaro, Milano, Federico
Publication date	2017-08-21
Publication information	Ortega, Alvaro, and Federico Milano. "Stochastic Transient Stability Analysis of Transmission Systems With Inclusion of Energy Storage Devices." IEEE, August 21, 2017. https://doi.org/10.1109/TPWRS.2017.2742400 .
Publisher	IEEE
Item record/more information	http://hdl.handle.net/10197/10011
Publisher's statement	© 2017 IEEE. Personal use of this material is permitted. Permission from IEEE must be obtained for all other uses, in any current or future media, including reprinting/republishing this material for advertising or promotional purposes, creating new collective works, for resale or redistribution to servers or lists, or reuse of any copyrighted component of this work in other works.
Publisher's version (DOI)	10.1109/TPWRS.2017.2742400

Downloaded 2026-05-02 00:26:00

The UCD community has made this article openly available. Please share how this access benefits you. Your story matters! (@ucd_oa)



© Some rights reserved. For more information

Stochastic Transient Stability Analysis of Transmission Systems with Inclusion of Energy Storage Devices

Álvaro Ortega, *Student Member, IEEE*, Federico Milano, *Fellow, IEEE*

Abstract—The letter provides a thorough stochastic analysis of the impact of energy storage systems on the transient stability of transmission grids. This impact is evaluated considering the combined effect of different energy storage technologies, fault clearing times and network topologies. The latter concerns the relative positions of faults, storage devices and synchronous machines. The case study consists of stochastic time-domain simulations carried out for the all-island, 1,479-bus model of the Irish transmission system that includes a real-world hybrid storage device. Results lead to some non-intuitive conclusions.

Index Terms—Transient stability, energy storage system, static synchronous compensator, stochastic time-domain simulation.

I. INTRODUCTION

THE potential of Voltage Source Converter (VSC)-based Energy Storage Systems (ESSs) to provide ancillary services to a transmission grid has been demonstrated in recent works in the literature [1]. These services include flattening the power provided by non-conventional power plants based on renewable sources (e.g., wind power plants), active power regulation in a transmission line, local and/or global frequency regulation, and Rate of Change of Frequency (ROCOF) mitigation. While these objectives are the main reasons that justify the economic viability of such devices, the ESS inherent ability to control both active and reactive powers is also expected, as a relevant byproduct, to increase the critical clearing times associated with a fault [2]. There is a lack, however, of studies that analyze in a systematic way the contribution of ESSs to the transient stability of a transmission system following a large disturbance. This letter aims to fill this gap and provides a comprehensive analysis that quantifies the impact of VSC-based ESSs on the transient stability of a transmission system modeled as a set of stochastic differential-algebraic equations. With this aim, this letter considers a large, real-world transmission network, and compares different ESS technologies, control strategies and network topologies.

II. CONFIGURATION OF THE ESS

Figure 1 shows a typical scheme of VSC-based ESS. The Storage Control block regulates a measurable quantity of the system, say w , while the VSC Control block regulates the voltages at the ac and dc sides of the VSC device, v_{ac} and v_{dc} , respectively. The full detailed fundamental-frequency, transient stability models of the VSC and Storage devices, as well as of their controllers, can be found in [3]. These are the models considered in the remainder of the letter.

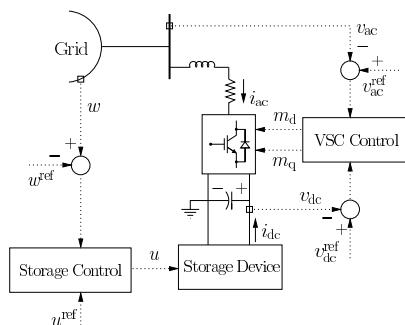

Fig. 1: VSC-based ESS coupled to the grid.

Álvaro Ortega and Federico Milano are with School of Electrical and Electronic Engineering, University College Dublin, Belfield, Ireland. E-mails: alvaro.ortega-manjavacas@ucdconnect.ie, federico.milano@ucd.ie

III. SYSTEM DESCRIPTION

The stochastic transient stability analysis of ESSs provided in this letter is based on the dynamic model of the all-island, 1,479-bus Irish transmission system. This model is based on the real-world power-flow data provided by the Irish TSO, EirGrid. Note, however, that dynamic data are guessed assuming conventional parameter values and do not represent a specific operating condition of the actual system. The generation is composed of 23 synchronous power plants, considering a 6th order model for the machines, and 176 wind farms, of which 142 are based on Doubly Fed Induction Generators (DFIGs) and 34 are based on Constant Speed Wind Turbines (CSWTs). The demand consists of 245 constant-impedance loads, totaling 3,100 MW and 965 MVar.

A pilot facility containing a hybrid ESS, consisting on a Flywheel (FES) and a Battery (BES) Energy Storage, has been installed in 2015 in county Offaly, Ireland [4]. The goal of the fully functioning system is to provide active power and/or primary frequency regulation. In this case study, a 40 MW/100 MVar FES and a 50 MW/100 MVar BES are studied separately in order to better understand the impact of each individual device on the transient stability of the system. The area where the ESS is installed includes a synchronous machine that provides 139 MW and 15 MVar as well as several wind power plants and loads. The controllers of both FES and BES devices are designed to regulate the frequency. This can be either the local frequency measured at the point of connection of the storage device (ω_{bus}) or the frequency of the center of inertia of the system (ω_{COI}). It is important to note that the primary purpose of the ESS is not to improve the transient stability of the system. This is just a byproduct of the ability of the ESS to regulate with a fast dynamic response both active and reactive powers. Hence, that the economic viability of the ESS is fully independent from its impact on transient stability. Note also that the power ratings of the FES and the BES considered in this study are larger than currently installed ones. This assumption allows better appreciating the effect of these device on the system. Moreover, the average size of energy storage devices is expected to increase considerably in the near future.

To study the interaction of the active and reactive power regulations provided by VSC-based ESS devices, the analysis is also carried out for a 100 MVar Static Synchronous Compensator (STATCOM) device [5]. This device is coupled to the system through the same VSC as the ESS in Fig. 1, but does not include the storage device and control and can thus provide exclusively reactive power regulation.

The following are relevant assumptions on the system model:

- Wind speeds of the wind power plants are modeled using uncorrelated stochastic differential equations that reproduce Weibull distributions.
- Load uncertainty is accounted through random loading levels in the range of $\pm 10\%$ with respect to base case conditions.
- The initial state of charge of the ESS is randomly assigned at the beginning of each simulation.
- VSC devices and control parameters are the same for the FES and the BES. Charge and discharge modes of the BES are duly taken into account.
- STATCOM parameters are the same as those of the VSC device and controller contained in the ESS.

IV. CASE STUDY

The analysis is based on the results of stochastic time domain simulations (1,000 simulations per scenario, 60 scenarios). The contingency is a three-phase fault, and two different locations of the fault are considered in order to represent two possible system topologies according to the relative position of the fault and the ESS with respect to the synchronous machine. These topologies are qualitatively illustrated in Fig. 2.

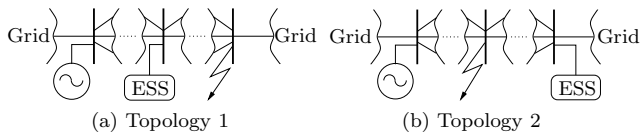

Fig. 2: Topologies of a power system facing a fault: (a) Topology 1: The ESS and the synchronous machines are on the same side with respect to the fault; (b) Topology 2: The fault occurs between the synchronous machine and the ESS.

The percentage of simulations that are unstable due to the loss of synchronism of the machine is then computed for different clearing times (CTs), and shown in Tables I and II, for each of the following scenarios:

- i. Irish system without ESSs.
- ii. One FES/BES providing local ω_{bus} control.
- iii. One FES/BES providing ω_{COI} control.
- iv. One STATCOM device providing local bus voltage, v_{ac} , control.

Note that both FES and BES devices also control v_{ac} through the quadrature component of the VSC.

TABLE I: Percentage of unstable simulations after a three-phase fault for Topology 1 in the Irish system for different CTs.

CT [ms]	105	110	115	120	125
No ESS	25.3	44.4	65.6	83.1	99.9
ω_{bus} Control					
FES	3.0	26.2	46.5	65.0	85.1
BES	8.9	31.8	50.4	71.1	88.0
ω_{COI} Control					
FES	1.5	24.1	43.5	63.6	81.9
BES	2.4	25.4	43.9	64.2	82.1
v_{ac} Control					
STATCOM	5.8	28.9	47.0	67.5	84.7

TABLE II: Percentage of unstable simulations after a three-phase fault for Topology 2 in the Irish system for different CTs.

CT [ms]	105	110	115	120	125
No ESS	29.8	48.7	69.4	86.5	100.0
ω_{bus} Control					
FES	19.2	41.0	57.0	80.2	97.7
BES	22.9	43.3	62.4	81.8	100.0
ω_{COI} Control					
FES	17.5	39.7	58.2	78.1	96.2
BES	17.8	39.8	59.1	78.2	96.6
v_{ac} Control					
STATCOM	16.7	39.1	57.4	76.9	95.5

Tables I and II show that regardless the variable regulated and the topology considered, the ESS always improves the transient stability of the system. Moreover, due to its faster response, a 40 MW FES has a greater effect than a 50 MW BES in the system transient stability for all scenarios considered. These results are well aligned with expectations. However, other results are less intuitive and are the main contributions of this study, as follows.

1) *Regulating the frequency of the COI provides fairly similar results than controlling a local bus frequency:* Following the transient caused by the fault, the trends of both ω_{COI} and ω_{bus} are similar in this system, and so are the response of the ESSs. However, the local frequency measurement is affected by the proximity to the fault and numerical issues, e.g., spikes due to noise and discontinuities. These issues may lead to slightly worse performance with respect to the control based on a global system quantity such as the frequency of the COI.

2) *If the fault occurs between the synchronous machine and the ESS, the support provided by the latter is substantially diminished:* This is due to the closer location of the fault with respect to the synchronous machine, and to the “barrier effect” that the fault creates between the machine and the ESS, limiting the support provided by the latter.

3) *The reactive power support of the ESS plays the mayor role in transient stability enhancement:* The comparison of the performances of ESS and STATCOM devices shows that the reactive regulation has a substantially greater impact than the active one. Sustaining the voltage during the fault, in fact, reduces the probability that the machine loses synchronism.

4) *The STATCOM device outperforms the ESS in some scenarios:* One would expect that the ESS, in the worst case, performs as good as a STATCOM device. However, this is not always the case, especially when the BES regulates the ω_{bus} . While the STATCOM regulates v_{ac} and v_{dc} separately, the ESS couples the control of v_{dc} and the control of the storage device (whose output is the current injected into the dc link of the VSC, i_{dc}). This coupling, along with the nonlinear relation $p_{\text{dc}} = v_{\text{dc}}i_{\text{dc}}$, affects the overall behavior of the ESS. If the dynamics of the storage device and/or of its controller are not sufficiently fast (as in the case of the BES) the overall performance of the ESS can be less effective than the STATCOM alone. Moreover, recent studies suggest that current saturations of the VSC increase the risk of instability of the converter [6]. Large disturbances such as three-phase faults may require a large amount of active power to be supplied/absorbed by the storage device very quickly, increasing the risk of saturation of the ESS, and therefore, reducing the CCT of the fault.

V. CONCLUSIONS AND FUTURE WORK

This letter presents a stochastic analysis of the transient stability of the Irish transmission system with inclusion of an ESS device. The case study provides both intuitive and less intuitive results. As expected, one can conclude that the ESS is able to increase considerably the CCTs of the faults that can occur in the system. The improvement of transient stability through ESS devices is fairly insensitive with respect to the kind of frequency signal (local or system-wide) utilized in the control. On the other hand, less intuitively, the performance of the ESS is not always better than that of a STATCOM. Moreover, such a performance highly depends on the relative position of the ESS with respect to both the fault and synchronous machines, as well as on the energy storage technology. Statistical information on potential fault locations appears thus to be crucial for the optimal placement of ESSs, as this increases the probability that such a device can properly support synchronous machines against faults.

REFERENCES

- [1] P. F. Ribeiro, B. K. Johnson, M. L. Crow, A. Arsoy, and Y. Liu, “Energy Storage Systems for Advanced Power Applications,” *Proceedings of the IEEE*, vol. 89, no. 12, pp. 1744–1756, Dec 2001.
- [2] A. Kanchanaharuthai, V. Chankong, and K. A. Loparo, “Transient Stability and Voltage Regulation in Multimachine Power Systems Vis-à-Vis STATCOM and Battery Energy Storage,” *IEEE Transactions on Power Systems*, vol. 30, no. 4, pp. 2404–2016, Sept. 2015.
- [3] Á. Ortega and F. Milano, “Generalized Model of VSC-based Energy Storage Systems for Transient Stability Analysis,” *IEEE Transactions on Power Systems*, 2016, (in press).
- [4] Schwungrad Energie Limited, “First Hybrid-Flywheel Energy Storage Plant in Europe Announced in Ireland,” URL: <http://schwungrad-energie.com/hybrid-flywheel-energy-storage-plant-europe-announced-ireland/>.
- [5] A. Yazdani and R. Iravani, *Voltage-Sourced Converters in Power Systems. Modeling, Control and Applications*, 1st ed. Wiley-IEEE Press, 2010.
- [6] H. Xin, L. Huang, L. Zhang, Z. Wang, and J. Hu, “Synchronous Instability Mechanism of P-f Droop-Controlled Voltage Source Converter Caused by Current Saturation,” *IEEE Transactions on Power Systems*, vol. 31, no. 6, pp. 5206–5207, Nov 2016.