

# Settling behaviour of polymer flocculated water-treatment sludge II: effects of floc structure and floc packing

Y.Q. Zhao

*School of Chemical Engineering, Queen's University Belfast, David Keir Building, Stranmillis Road,  
Belfast BT9 5AG, Northern Ireland, UK*

\*\*\*\*\*

Corresponding detail: Tel.: +44-(0)28-9027 4665; Fax: +44 -(0)28-9038 1753.

E-mail: y.zhao@qub.ac.uk

## Abstract

On the basis of experiments carried out using an image analysis system and static zone settlement, the alum sludge floc structure and the floc packing status with varied polymer dosages were examined in greater detail to reveal the link with the settling behaviour manifested in the “CML30 method”. The results of image analysis lead to the findings of the floc size with a pattern in initially great increase with low polymer dose and finally a plateau being reached at higher amount of polymer addition. Meanwhile, a polymer dosage in the range of 2.0 – 20.0 mg/l (for sludge SS = 4,595 mg/l) can result in the increase of the floc fractal dimension ( $D_F$ ) up to an average value of 1.72 (raw sludge  $D_F$  being 1.06), indicating greater compactness of the floc solids. These floc features control the settling behaviour of the “CML30 method”, especially in small polymer dosages. However, in large polymer doses, the controlling factor is derived from the floc ‘packing’ status (referring to the inter – floc contact manner). This ‘packing’ status may associate with viscosity of settling medium (supernatant) and the excess polymer in bulk solution. All these affect the sludge floc networked structure in overdosing range.

**Keywords:** Alum sludge; Floc packing; Floc size; Polymer; Settlement; Structure; Theoretical prediction

## **1. Introduction**

A simple test method (termed as the “CML30 method”) for identifying the optimum dosage during polymer conditioning of water-treatment sludge has been developed in a previous study [1]. The “CML30 test method” is based on 30 min settlement of polymer conditioned alum sludge in a 100 ml measuring cylinder. It has been observed that the salient feature of 30 min settlement was characterised by a minimum height of the sludge-supernatant interface. More importantly, the polymer dosage associated with the minimum interfacial height coincided with the optimum dosage which was evaluated by the modified SRF (specific resistance to filtration) [1,2]. However, the precise controls on the settlement behaviour are unclear.

As is well known, sludge dewatering via gravity is known as thickening in which the separation of water and sludge solid is achieved by the downward movement of the solid relative to the liquid. Although this kind of settling has been examined in many studies [3,4,5], knowledge of the effect of polymer conditioning on thickening behaviour is still lacking. In particular, the interaction between polymer and water treatment sludge, commonly known as alum sludge, is complex and the settling behaviour of this suspension is a physicochemical process. In spite of the efforts described in an earlier paper [6] which provides ample information focused on the detailed analyses of settling curves, it is inadequate in view of the complexity of the settling process. In this paper, by making use of the image analysis system, floc structural characteristics such as floc size, density and fractal dimension are examined in greater detail in terms of their response to the polymer dosage. The bulk settling behaviour is examined with the emphasis on the link between floc structure,

floc packing and settling environment in bulk solution. In addition, a mathematical description of settling behaviour was attempted, although it was proved that the results were not very satisfactory.

## 2. Theory

### 2.1 Floc size, density and fractal dimension ( $D_F$ )

Floc size and density are related in an empirical form of:

$$\rho_e = A d^{-n} \quad (1)$$

where  $d$  is floc effective diameter and  $\rho_e$  is the effective density. (Here, the floc effective diameter is defined as the geometric mean  $d = (d_{\max} \times d_{\min})^{1/2}$  in which  $d_{\max}$  and  $d_{\min}$  are the maximum and minimum dimensions across the floc image respectively. The floc effective density,  $\rho_e$ , is defined by the density difference  $\rho_e = \rho_f - \rho_w$  in which  $\rho_f$  and  $\rho_w$  refer to the density of the floc and water respectively).  $A$  and  $n$  are fitting constants. Parameter  $n$  is recognised as reflecting the fractal nature of the floc  $n = 3 - D_F$ , where  $D_F$  ( $1 < D_F < 3$ ) is the fractal dimension. The fractal dimension is a quantitative measurement of floc structure and provides an indication of how the particles are organized within the floc interior: the higher the fractal dimension, the more compact the floc.

### 2.2 Floc volume fraction ( $\Phi_f$ )

Floc volume fraction ( $\Phi_f$ ) refers the ratio of the volume of the total sludge flocs to the volume of sludge samples. The estimation of  $\Phi_f$  is based on image analysis data. Before this, the total number of sludge flocs at fixed polymer dose should be calculated first.

As  $V_f$  ( $V_f = \pi d^3/6$ ) represents the individual sludge floc volume,  $C_f$  ( $C_f = \rho_e/(1-\rho_w/\rho_s)$ ) is the solids concentration of sludge floc [7], the individual floc solid mass ( $m_s$ ) can be expressed as  $m_s = V_f \cdot C_f$ , i.e.

$$m_s = \frac{\pi}{6} \cdot \frac{Ad^{3-n}}{\left(1 - \frac{\rho_w}{\rho_s}\right)} \quad (2)$$

where,  $\rho_s$  is floc dry density. Thus, the mass ( $M_s$ ) of all the flocs that are caught and calculated by the image analysis system is as follows:

$$M_s = \sum_1^N m_s \quad (3)$$

Therefore, the average mass of each floc can be obtained by dividing  $M_s$  with floc number ( $N$ ) that was caught and calculated in the image analysis system.

$$\bar{m}_s = \frac{M_s}{N} \quad (4)$$

And then, the total number ( $N_T$ ) of flocs in a fixed polymer dosage can be determined by the term

$$N_T = \psi \cdot \frac{V \cdot C_s}{\bar{m}_s} \quad (5)$$

where,  $V$  is volume of sludge samples,  $C_s$  is sludge solid concentration.  $\psi$  is a coefficient defined as the mass ratio (percent) of flocs caught by the image system and the total mass in sludge solution, to take account of the effect of fine sludge particles ( $\leq 49 \mu\text{m}$ ) which were below the limitation of the image system and could not be caught during the measurement. It

was obtained by the comparison with the floc mass distribution curves of sludge suspensions between image system and Galai (CIS-100). Here,  $\psi = 79\%$  (data not shown).

As  $V_f$  represents the individual sludge floc volume, the average volume of each floc can be calculated by

$$\bar{V}_f = \frac{\sum_1^N V_f}{N} \quad (6)$$

where,  $N$  is the floc number that was captured by the image analysis system. Since then, the total sludge floc volume ( $V_{T,f}$ ) at each polymer dosage is determined as follows:

$$V_{T,f} = \bar{V}_f \cdot N_T \quad (7)$$

where,  $N_T$  is the total sludge floc number at each polymer dosage calculated in the floc mass basis (see Eq.(5)).  $\Phi_f$  is actually an expression of  $V_{T,f}$  in the ratio of floc to the volume of sludge samples. That is:

$$\Phi_f = \frac{V_{T,f}}{V} \quad (8)$$

### ***2.3 Quantitative description of settling behaviour --- Ekdawi – Hunter approach***

Ekdawi and Hunter [8] and Hunter and Ekdawi [9] developed models to quantitatively describe the sedimentation behaviour of disperse and coagulated suspensions by use of a slightly modified form of Stoke's law. In the case of coagulated suspensions, Ekdawi and Hunter [8] considered the sedimentation behaviour by introducing a semi-empirical parameter ( $\Gamma$ ) which modified true particle concentration by accounting for the restricted flow of liquid

through the coagulum.  $\Gamma$  was defined as an indicator of the degree to which the true particle volume fraction is effectively augmented by the restriction of the fluid flow:

$$\Gamma = \Phi_f' / \Phi_f \quad (9)$$

where,  $\Phi_f'$  is the apparent volume fraction exhibited by the settling system. By introducing  $\Gamma$ , Ekdawi and Hunter [8] established the following model, in which the sedimentation velocity of coagulated suspension ( $v$ ) can be expressed as:

$$v = \frac{v_o(1 - \Phi_f)}{\Gamma} \cdot (1 - \Gamma \cdot \Phi_f)^{3.5} \quad (10)$$

where,  $v_o$  is the Stoke's law settling velocity of discrete particles.

### 3. Materials and methods

#### 3.1. Sludge, polymer and conditioning procedure

The sludge used in this study was collected from sludge holding tank of a waterworks receiving a low-turbidity, coloured water coagulated with aluminium sulphate. The sludge had an initial solids concentration of 4,595 mg/l and pH of 6.8. After collection, the sludge was stored at room temperature ( $20 \pm 2^\circ\text{C}$ ) for the period not exceeding two weeks. The sludge was conditioned using Magnafloc LT25 (*Allied Colloids UK Ltd., now Ciba Speciality Chemicals Ltd.*), this being an anionic organic polymer with molecular weight in the range  $1.0-1.5 \times 10^7$  and charge density of 15-30 %. A 0.01 % stock solution was prepared using nanopure water and allowed to stand for 24 h prior to use. Thereafter the stock solution was used within the next 24 h period before being discarded. Polymer was added to 200 ml sludge

samples with dosages in the range 0-25 mg/l. Following polymer addition, the sludge was subjected to 30 s of rapid mixing followed by 1 min slow mixing to generate flocs.

### ***3.2. CCTV image analysis system***

The components of a CCTV image analysis system are illustrated in Fig. 1. Floc properties such as floc size (effective diameter), effective density, individual floc free-settling velocity etc. could be determined by the system. For polymer dose of 2-20 mg/l, 50 ml of conditioned sludge was diluted using 250 ml nanopure water and stirred slowly (speed at 13 rpm,  $G = 6.5 \text{ s}^{-1}$ ) in a Jar test equipment which was held in a water bath at 20°C. After slow mixing for 10 min, small samples of flocs were transferred using a 0.7 cm diameter dipping tube and carefully released into the sedimentation column (see Fig. 1). Movements of individual flocs in the settling column were recorded on tape by a video camera equipped with a microscope. Thereafter, the recorded flocs were analysed using the computed image analysis program via the replaying of the video tape, as shown in Fig. 1. Details of the CCTV image system are provided by Bache and Hossain [10] and Bache et al. [11]. Each data set associated with per polymer dose in this study contained details of over 100 flocs.

Fig. 1 [here]

### ***3.3. Settling tests (in 100 ml measuring cylinders)***

In order to describe the settling behaviour mathematically, zone settling velocity (ZSV) was obtained through the static settling tests which were conducted in 100 ml measuring cylinders (30 mm in diameter). Initially, polymer conditioned sludge of each run was transferred to a 100 ml measuring cylinder and allowed to settle. The position of the sludge / supernatant

interface was recorded as a function of settling time. ZSV was then calculated from the settling curve, i.e. interface height vs. time.

## 4. Results

### *4.1 Response of floc physical properties to polymer dose*

The trends shown in Fig. 2 (the vertical axis representing a mass fraction of the total mass which is derived from the flocs captured on CCTV) illustrate the sensitivity of the particle size distribution to the polymer dosage. It is seen from Fig. 2 that, initially, the overall particle size distribution increases with the polymer dose under 10 mg/l, which is the optimum dose determined by modified SRF and “CML30 method” [1]. Beyond 10 mg/l the particle size distribution becomes insensitive to further increases in polymer dose.

Fig. 2 [here]

To illustrate the change of particle size quantitatively, the median particle diameter ( $d_{50}$ , 50% of particle size less than  $d_{50}$  value) derived from each particle size distribution curve is summarized in Table 1. This provides a useful indicator of the response of trends (in Fig. 2) to increasing polymer dose. It is noted from Table 1 that  $d_{50}$  increases significantly with polymer dose at initial range and then remains constant with relative high polymer dose.

Table 1  $d_{50}$  as a function of polymer dose based on the data shown in Fig. 2

Fig. 3 shows one of the examples of floc size – density relationship (at polymer dose of 15 mg/l for sludge solid concentration of 4,595 mg/l). The data obtained from the image analysis

system after the sedimentation of individual flocs as illustrated in Fig. 1. The trend line in Fig. 3 was calculated using a least squares analysis and could be represented by the empirical expression, as shown in Eq.(1). A full summary of the values of the constant  $A$  and  $n$  as well as  $D_F$  ( $D_F = 3 - n$ ) over the polymer range studied is listed in Table 2.

Fig. 3 [here]

Table 2 Fractal dimension of sludge floc at different polymer dosages  
(errors refer to the 95% confidence interval)

From Table 2, it is seen that there is significant difference of the fractal dimension ( $D_F$ ) between raw and polymer dosed sludge samples. Once the dosage exceeds about 2.0 mg/l, the  $D_F$  value, though showing a marginal increase with dose, is more or less constant at  $1.72 \pm 0.09$ , indicating that the degree of sludge floc compactness is insensitive to polymer dosage.

#### ***4.2 Floc packing***

The results of calculated total sludge floc number within 200 ml sludge samples versus polymer dosage are listed in Table 3. This Table shows that polymer dosage from 2.0 to 20.0 mg/l can decrease the original sludge particle number by 5 to 245 times.

Table 3 Total sludge floc numbers in 200 ml samples (SS = 4,595 mg/l)

Fig. 4 shows a plot of the calculated floc volume fraction ( $\Phi_f$ ) (referring Eq.(8)) in response to polymer dosage for the case of sludge solids concentration of 4,595 mg/l. It shows that increasing additions of polymer lead to a reduction in the total floc volume fraction.

Fig. 4 [here]

However, Fig. 5 provides a direct observation of floc packing in large polymer dosage (25 mg/l, being overdosing). Here the term “*packing*” refers to the inter – floc contact manner. There is obviously space between flocs shown in Fig. 5. This long – term zone settlement shows that the relative volume occupied by the floc (also known as floc volume fraction) displays very different behaviour compared with the behaviour shown in Fig. 4 if the final thickened sludge volume is to be taken as indicative sludge volume fraction. This could be the implication of interaction between polymer and sludge flocs.

Fig. 5 [here]

### ***4.3 Theoretical prediction of settling behaviour***

An attempt to apply Ekdawi and Hunter’s [8] model was carried out. Here, the Stoke’s law settling velocity of flocs at a fixed polymer dosage was represented by a velocity on the mean ( $v_0$ ) defined by Bache et al.[11]:

$$\bar{v}_0 = \frac{\sum_1^N d_i \cdot v_{0,i}}{\sum_1^N d_i} \quad (11)$$

where  $v_{0,i}$  and  $d_i$  are the individual floc free settling velocity and floc size respectively (both from image analysis). The parameter,  $\Gamma$ , in Ekdawi and Hunter's [8] model was defined (in this study) as a ratio of the apparent sludge floc volume fraction exhibited by the long term settling test and the actual floc volume as a fraction, calculated via image analysis data, i.e.

$$\Gamma = (\text{Apparent } \Phi_f \text{ in long term zone settlement}) / (\text{Calculated } \Phi_f \text{ by image analysis data})$$

Direct application of Eq.(10) to predict the zone settling velocity (ZSV) was performed using the data of both the image analysis and the zone settling test (for the case of 100 ml measuring cylinder corresponding to the sludge solid concentration of 4,595 mg/l). The results of the 'measured ZSV' (calculated from the settling curve, interface height vs. time) and predicted ZSV are illustrated in Fig. 6. It can be seen from Fig. 6 that the trends of ZSV between measured and predicted values have strong similarities but are certainly not coincident. This reflects the complexity of the settling behaviour and the difficulty in theoretical description of coagulated suspension.

Fig. 6 [here]

## 5. Discussion

The most likely manifestation of the interaction between the sludge and the polymer is the production of flocs. It is reasonable to believe that the floc properties are tied to matters of settling behaviour. Therefore, the detailed profiles of floc properties, particularly the floc size, density and structure, with varied polymer dose become the first main focus of this investigation. The image analysis system provides a useful tool for revealing detailed

information of floc physical properties. The floc size in this study follows a pattern of great initial increase with low polymer dosage, with a plateau being reached at higher amounts of polymer addition (see Fig. 2 and Table 1). This result agrees with that reported by Langer et al. [12] and Wen et al. [13] and differs from the data reported by Wu et al. [14] and Chu and Lee [15] who demonstrated a continuous increase of floc size with polymer dosage. The discrepancy may be attributed to the different polymer features, such as charge type and molecular weight, used by different investigators as suggested by Lee and Liu [16]. However, the shift of floc size towards large diameter by polymer dosing is the considerable dominant factor in controlling the settling behaviour in “CML30 method” [1].

On the other hand, data in Table 2 shows that the raw alum sludge has a  $D_F$  of 1.06 which is in good agreement with the result reported by Wu et al. [14] ( $D_F = 1.18$  for raw alum sludge). More importantly, polymer dosing from 2.0 – 20.0 mg/l (for sludge SS = 4,595 mg/l) can result in a considerable increase of  $D_F$  up to an average value of 1.72 (see Table 2), indicating greater compactness of the floc solids. As noted,  $D_F$  is a quantitative measurement of floc structure (referred to floc mass) and a description of how the original particles are organized within the floc interior. Yet, the change of floc structure may be considered as one of the factors to control the settling behaviour, especially during underdose range as illustrated in an earlier paper [6]. However, it is noted that the fact that  $D_F$  hardly changes with dosages above 2.0 mg/l (see Table 2) does not appear to influence the position of the interfacial height in the “CML30 method”.

Other important features derived from the image system are the results of the calculation of the floc volume fraction, shown in Fig. 4. The trend of progressively decreased floc volume fraction with increased polymer addition reflects the larger, more dense and more compacted flocs associated with the concomitant increase of polymer. However, in spite of the improvement of floc structure (as gauged by the  $D_F$  when polymer was added), large polymer dosage can cause the floc packing problem. Fig. 5 clearly shows a sketch of settlement behaviour in which the floc volume fraction displays the opposite behaviour as revealed from the image system data (Fig. 4). This feature is illustrated in Fig. 7. The salient point of Fig. 7 is the 'gap' between volume fractions in overdosing range. The reason this 'gap' occurs is unclear but is associated with the viscosity feature of supernatant in bulk solution [6]. In addition, Johnson et al. [17] emphasized that untrapped colloidal material can also affect settling velocity by clogging pores and altering the flow conditions around and within settling aggregates. More importantly, with regard to solids compression in terms of thickening, it is known that when the flocs are in contact with one another, they can form a structure that has resistance to crushing [4].

Fig. 7 [here]

The settling behaviour of a flocculating suspension is difficult to describe on the basis of theory. ZSV may depend on many factors since the flocs are of different sizes, of different degree of compactness and are interconnected to form large aggregate structures. In fact, an attempt to explain the settlement behaviour of this study in some other models was unsuccessful. Although an unsatisfactory result was obtained for the application of Ekdawi and Hunter's [8] model in this study, the rough agreement between measured ZSV and

predicted ZSV in Fig. 6 demonstrates that  $\Gamma$ , i.e. the floc ‘packing’ status, is one of the principal factors controlling the movement of the interface.

Overall, it is known that many factors such as floc size, density, velocity, viscosity, flocculation during settling and wall effect, as well as the formation of aggregate structures in solids compression can affect the settling behaviour. Therefore, it is reasonable to believe that any single index may not determine the true settling behaviour as displayed in “CML30 method”. It is the integrated effects of these factors that control the true settling behaviour.

## 6. Conclusions

The data presented in this study may support the following conclusions.

- In spite of the fact of the increasing floc size pattern, rapid increase of floc size in the underdose range (polymer dose < 10 mg/l corresponding to the sludge solids concentration of 4,595 mg/l in this study) is a reasonable factor to control the settling behaviour. More compacted floc (evaluated as  $D_F$ ) with increased polymer dose enhances the settling process in this range.
- In overdosing range, the formation of a networked sludge structure plays a controlling role on settling behaviour. This networked structure, which occurs with excess polymer, may link flocs in a complex way and appears to cause a packing regime and therefore determines the position of the settling process.
- Floc packing of polymer flocculated sludge suspension plays a vital role in to describing the settling behaviour on a theoretical basis. Further investigation of this aspect is highly desirable.

## Acknowledgements

I am very grateful to Dr D. H. Bache of University of Strathclyde for his continued invaluable guidance, generous advice and helpful criticism during this study. I am also grateful to Dr E Rasool for his technical assistance to operate the image analysis system. Mr A. Green is also thanked for his valuable comments for the preparation of this manuscript. The valuable suggestion and comments from referees are highly appreciated. I am indebted to West of Scotland Water (now the Scottish Water) for the provision of material and access to a number of water treatment works.

## References

- [1] D. H. Bache, Y. Q. Zhao, Optimising polymer use in alum sludge conditioning: an *ad hoc* test, *J. Wat. SRT-Aqua*, 50 (1) (2001) 29-38.
- [2] Y. Q. Zhao, E. N. Papavasiliopoulos, D. H. Bache, Clogging of filter medium by excess polymer during alum sludge filtration, *Filtration and Separation*, 35 (10) (1998) 947-950.
- [3] R. J. Wakeman, Thickening and filtration: a review and evaluation of recent research, *Trans IChemE*, 59 (1981) 147-160.
- [4] B. Fitch, Thickening theories – an analysis, *AIChE Journal*, 39 (1) (1993) 27-36.
- [5] G. W. Chen, I. L. Chang, W. T. Hung, D. J. Lee, Regimes for zone settling of waste activated sludges, *Wat. Res.* 30 (8) (1996) 1844-1850.
- [6] Y. Q. Zhao, Settling behaviour of polymer flocculated water-treatment sludge I: analyses of settling curves, (Submitted to *Separation and Purification Technology*)
- [7] D. H. Bache, E. Rasool, D. Moffat, F. J. McGilligan, On the strength and character of alumino-humic flocs, *Wat. Sci. Tech.* 40 (9) (1999) 81-88.
- [8] N. Ekdawi, R. J. Hunter, Sedimentation of disperse and coagulated suspensions at high particle concentrations, *Colloids and Surfaces*, 15 (1985) 147-159.
- [9] R. J. Hunter, N. Ekdawi, The sedimentation behaviour of coagulated particles of small radius, *Colloids and Surfaces*, 18 (1986) 325-340.

- [10] D. H. Bache, M. D. Hossain, Optimum coagulation conditions for coloured water in terms of floc properties, *J. Wat. SRT-Aqua*, 40 (1991) 170-178.
- [11] D. H. Bache, E. Rasool, A. Ail, J. F. McGilligan, Floc character: measurement and role in optimum dosing, *J. Water SRT-Aqua*, 44 (2) (1995) 83 -92.
- [12] S. J. Langer, R. Klute, H. H. Hahn, Mechanisms of floc formation in sludge conditioning with polymers, *Wat. Sci. Tech.* 30 (8) (1994) 129-138.
- [13] H. J. Wen, C. I. Liu, D. J. Lee, Size and density of flocculated sludge flocs, *J. Environ. Sci. Health*, A32 (4) (1997) 1125-1137.
- [14] C. C. Wu, C. Huang, D. J. Lee, Effects of polymer dosage on alum sludge dewatering characteristics and physical properties, *Colloids and Surfaces A: Physicochemical and Engineering Aspects*, 122 (1-3) (1997) 89-96.
- [15] C. P. Chu, D. J. Lee, Moisture distribution in sludge: effects of polymer conditioning, *J. of Environmental Engineering*, 125 (1999) 340-345.
- [16] C. H. Lee, J. C. Liu, Sludge dewaterability and floc structure in dual polymer conditioning, *Advances in Environmental Research*, 5 (2) (2001) 129-136.
- [17] C. P. Johnson, X. Li, B. E. Logan, Settling velocities of fractal aggregates, *Environ. Sci. Technol.* 30 (1996)1911-1918.

Table 1  $d_{50}$  as a function of polymer dose based on the data shown in Fig. 2

Polymer dose in sludge sample (mg/l)	$d_{50}$ (mm)
0	0.197
2	0.766
5	1.012
10	1.652
15	1.800
20	1.829

*Note:* Alum sludge solid concentration is 4,595 mg/l.

Table 2 Fractal dimension of sludge floc at different polymer dosages (errors refer to the 95% confidence interval)

Polymer dose (mg/l)	A	$n$	$D_F$	
0	0.0003	$1.94 \pm 0.23$	$1.06 \pm 0.23$	
2	0.0007	$1.29 \pm 0.14$	$1.71 \pm 0.14$	} Average value $1.72 \pm 0.09$
5	0.001	$1.35 \pm 0.14$	$1.65 \pm 0.14$	
10	0.0026	$1.28 \pm 0.08$	$1.72 \pm 0.08$	
15	0.0045	$1.25 \pm 0.05$	$1.75 \pm 0.05$	
20	0.0065	$1.23 \pm 0.06$	$1.77 \pm 0.06$	

*Note:* Alum sludge solid concentration is 4,595 mg/l.

Table 3 Total sludge floc numbers in 200 ml samples (SS = 4,595 mg/l)

Polymer dose (mg/l)	Total floc numbers ( $\times 10^6$ )
0.0	9.15
2.0	1.93
5.0	0.767
10.0	0.143
15.0	0.0625
20.0	0.0372

### **Figure captions**

Fig. 1 Schematic methodology for images analysis system: recording of floc images (above);  
floc images digitised and analysed (bottom)

Fig. 2 Trend lines of mass based particle size distributions of polymer dosed alum sludge  
(sludge solids concentration: 4,595 mg/l)

Fig. 3 Relationship between floc effective diameter and effective density (polymer dose at  
15.0 mg/l, SS=4,595 mg/l)

Fig. 4 Sludge floc volume fraction as a function of polymer dose (SS= 4,595 mg/l)

Fig. 5 Close observation of floc packing after 2 h settlement in 100 ml measuring cylinder for  
alum sludge (SS = 4,595 mg/l) dosed by polymer Magnafloc LT 25 at 25.0 mg/l

Fig. 6 Comparison of measured and predicted ZSV (for the 100 ml measuring cylinder set,  
SS = 4,595 mg/l)

Fig. 7 Floc packing problem by comparing the data of floc volume fraction between image  
analysis and long-term tests (SS = 4,595 mg/l).

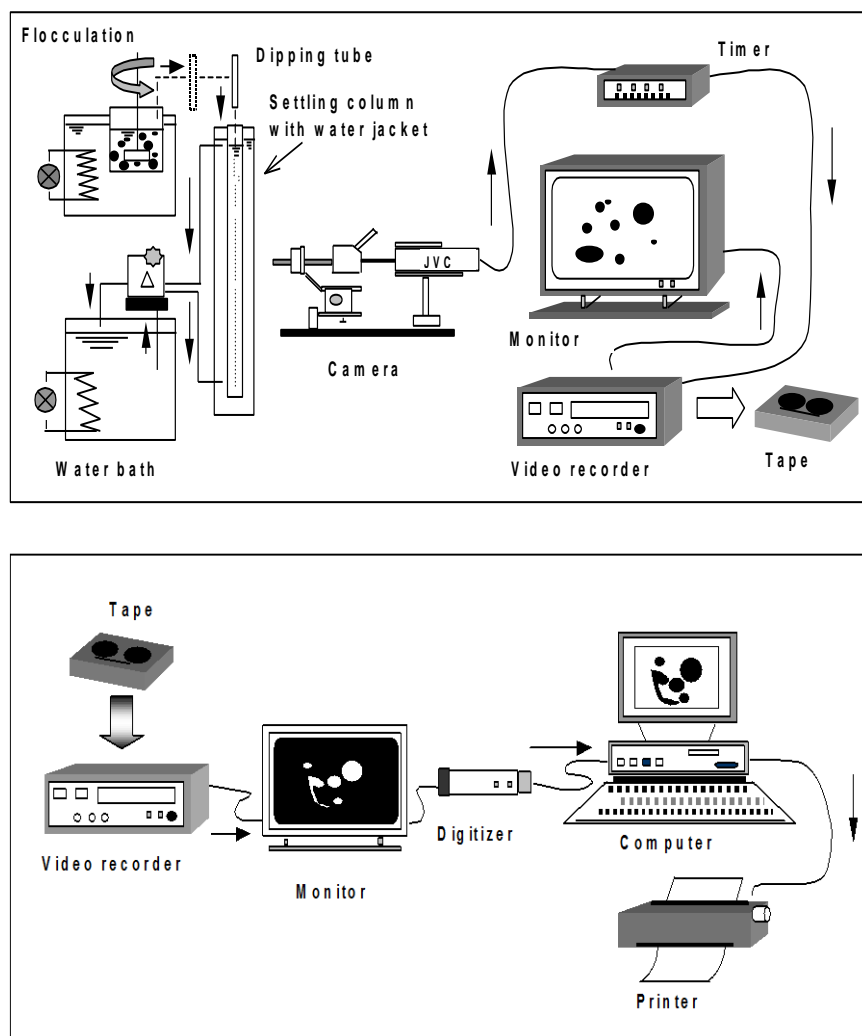

Fig. 1 Schematic methodology for images analysis system: recording of floc images (above); floc images digitised and analysed (bottom)

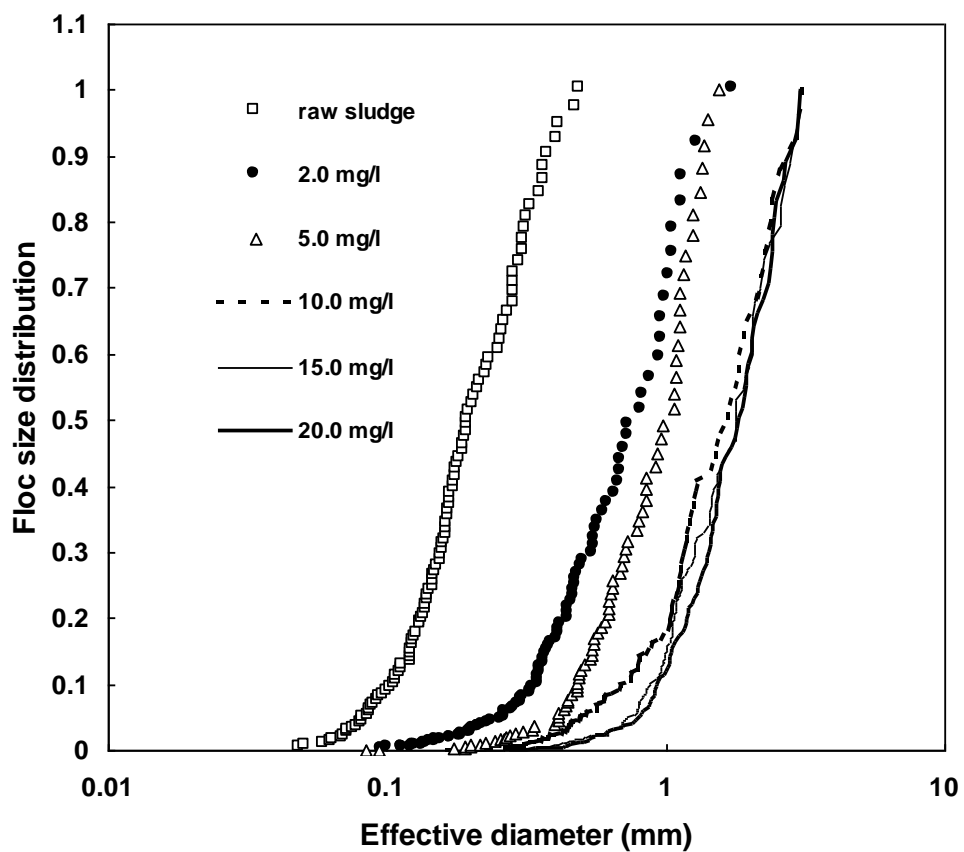

Fig. 2 Trend lines of mass based particle size distributions of polymer dosed alum sludge (sludge solids concentration: 4,595 mg/l)

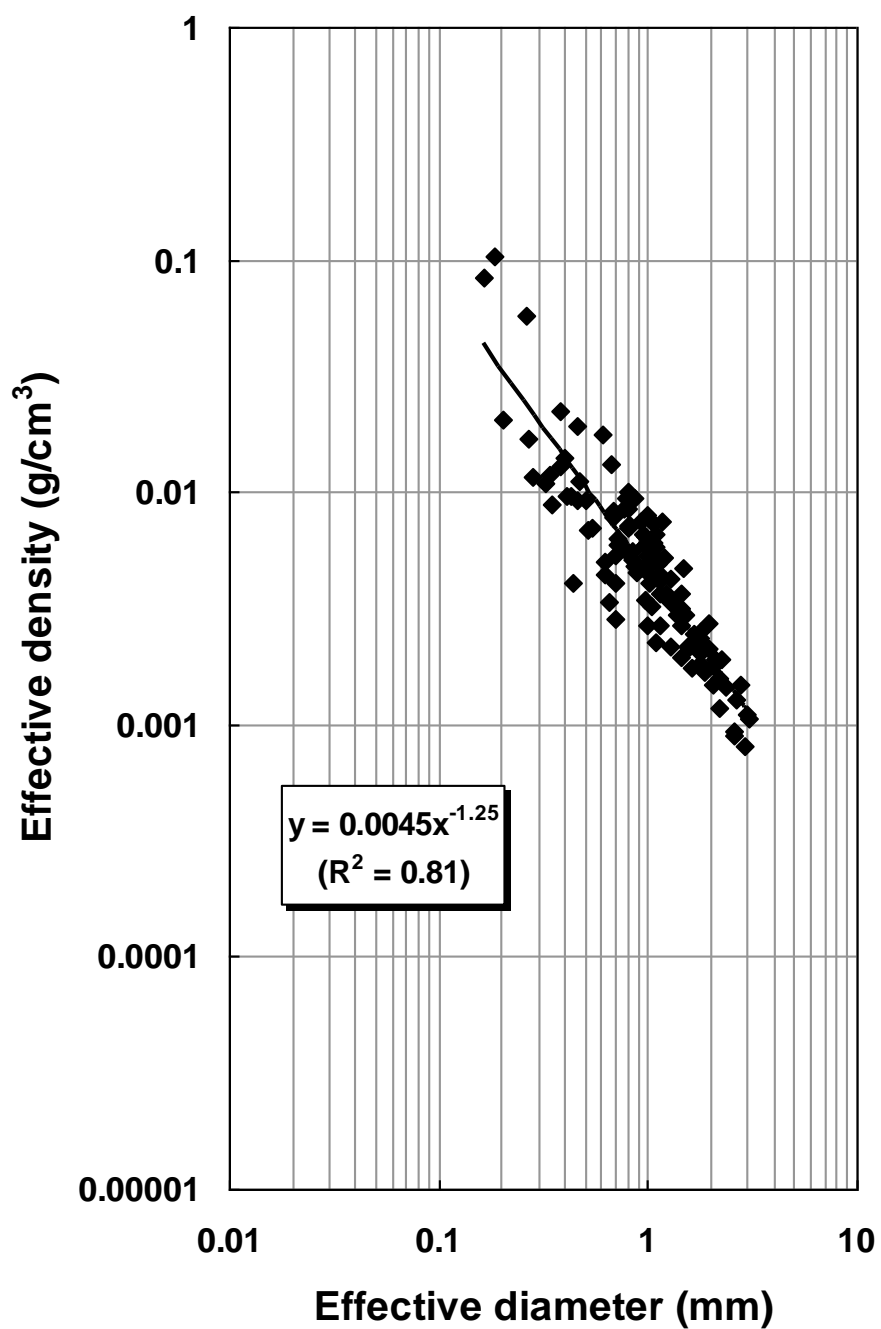

Fig. 3 Relationship between floc effective diameter and effective density  
(polymer dose at 15.0 mg/l, SS=4,595 mg/l)

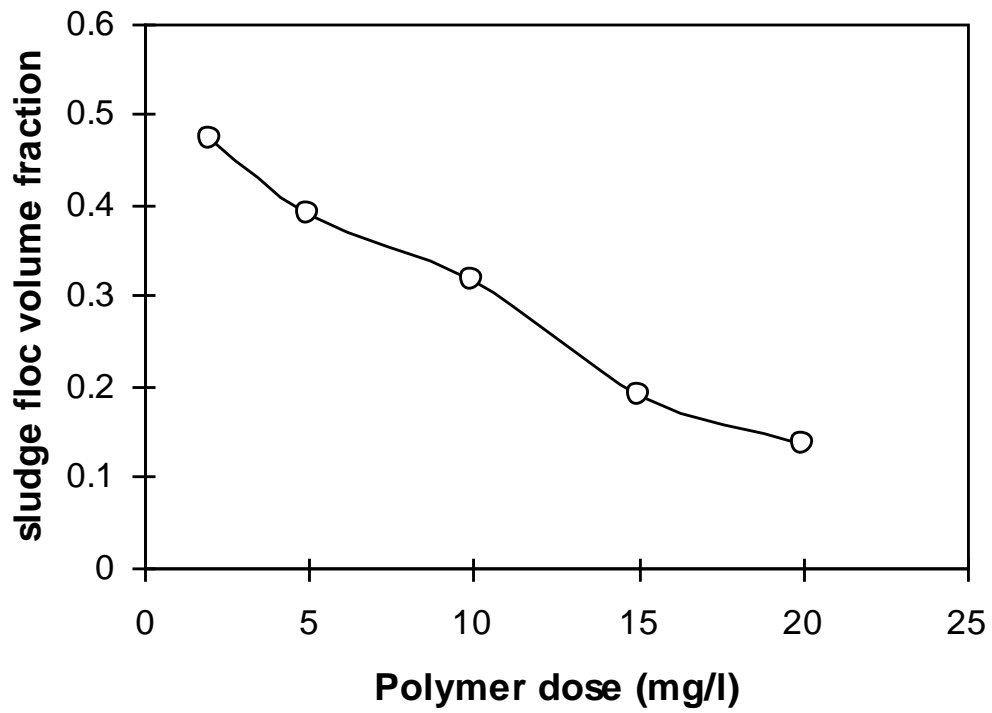

Fig. 4 Sludge floc volume fraction as a function of polymer dose (SS= 4,595 mg/l)

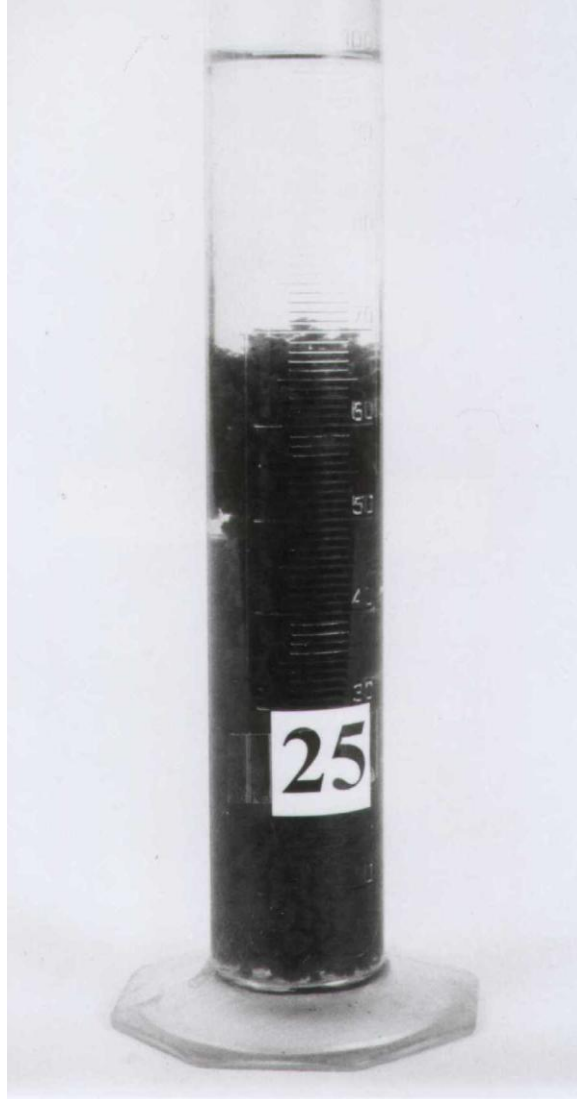

Fig. 5 Close observation of floc packing after 2 h settlement in 100 ml measuring cylinder for alum sludge (SS = 4,595 mg/l) dosed by polymer Magnafloc LT 25 at 25.0 mg/l

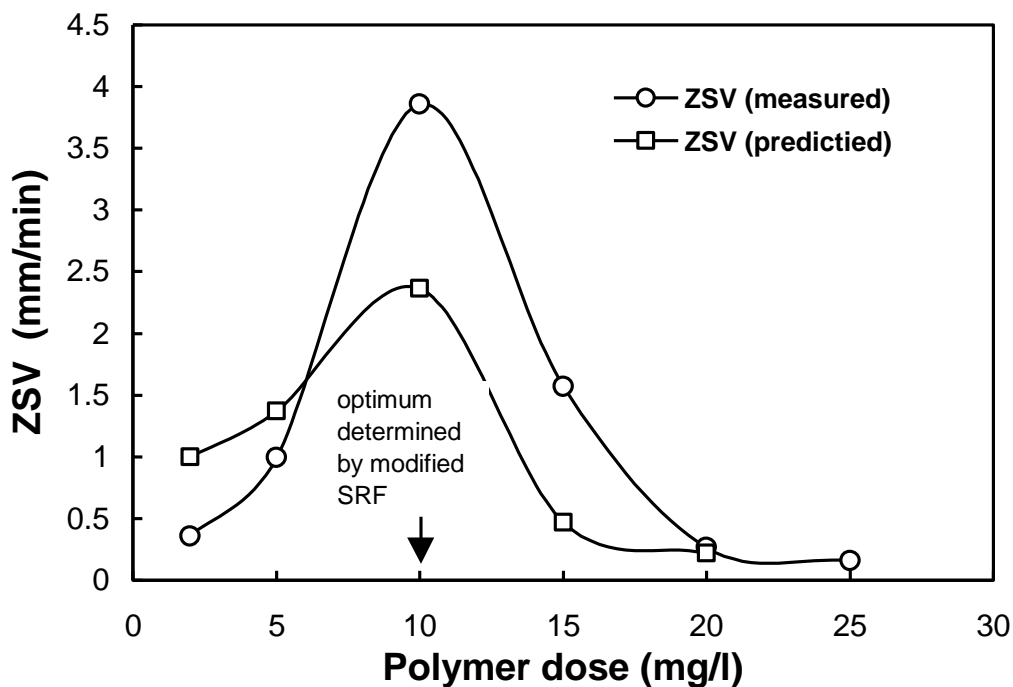

Fig. 6 Comparison of measured and predicted ZSV (for the 100 ml measuring cylinder set, SS = 4,595 mg/l)

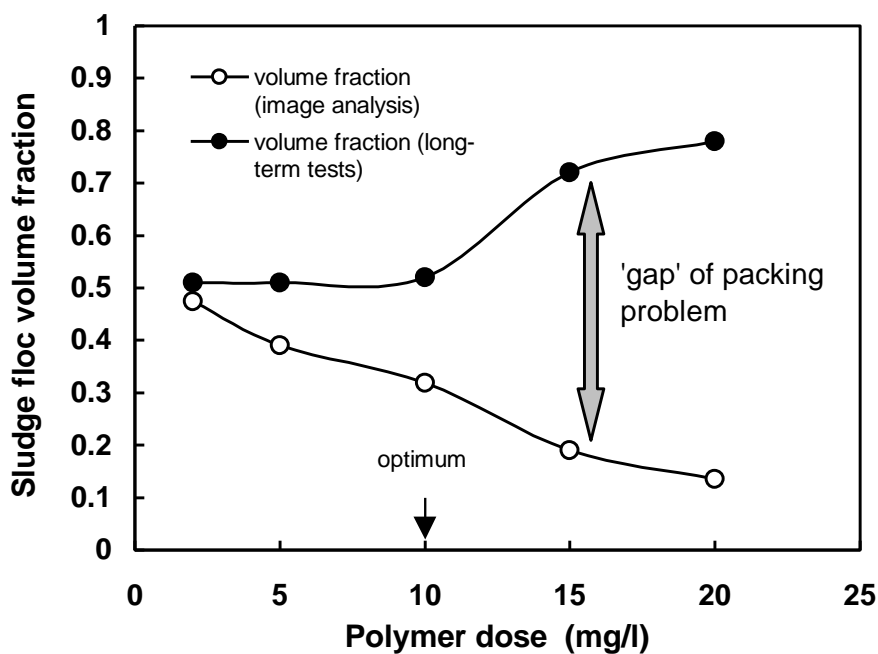

Fig. 7 Floc packing problem by comparing the data of floc volume fraction between image analysis and long-term tests (SS = 4,595 mg/l)