



Title	A Robust Computational Framework for Mid-Term Techno-Economical Assessment of Energy Storage
Authors(s)	Maghouli, Pourya, Soroudi, Alireza, Keane, Andrew
Publication date	2015-10
Publication information	Maghouli, Pourya, Alireza Soroudi, and Andrew Keane. "A Robust Computational Framework for Mid-Term Techno-Economical Assessment of Energy Storage." IET, October 2015. https://doi.org/10.1049/iet-gtd.2015.0453 .
Publisher	IET
Item record/more information	http://hdl.handle.net/10197/7241
Publisher's version (DOI)	10.1049/iet-gtd.2015.0453

Downloaded 2026-05-01 23:37:47

The UCD community has made this article openly available. Please share how this access benefits you. Your story matters! (@ucd_oa)



© Some rights reserved. For more information

A Robust Computational Framework for Mid-Term Techno-Economical Assessment of Energy Storage

Pouria Maghouli, Alireza Soroudi, Andrew Keane

Abstract—Rapid expansion and integration of wind energy is restrained due to transmission capacity constraints and conventional generation technologies limited operational flexibility in today's power systems. Energy storage is an attractive option to integrate and utilize more renewable energy without major and timely upgrade of existing transmission infrastructure. Also it can be considered as a mean for differing the reinforcement plans. The evaluation of energy storage deployment projects is a challenging task due to severe uncertainty of wind power generation. In this paper a robust techno-economic framework is proposed for energy storage evaluation based on Information Gap Decision Theory for handling wind generation uncertainty. The total social cost of the system including conventional generators' fuel and pollution cost and wind power curtailment cost is optimized considering generators operational constraints and transmission system capacity limitations based on the DC model of the power grid. The effect of storage devices on system performance is evaluated taking into account wind power uncertainty. The proposed method is conducted on the modified IEEE Reliability Test System (IEEE-RTS) and the modified IEEE 118 bus test system to assess its applicability and performance in midterm robust evaluation of energy storage implementation plans.

Index Terms—DC optimal power flow, Storage devices, Transmission capacity constraints, Wind power generation, Information Gap Decision Theory.

NOMENCLATURE

Sets & Indices

g	Index for thermal generation units
j, i	Index for network buses
t	Index for time interval t
t_y	Yearly time index
Ω_{G_i}	Set of generating units connected to bus i
Ω_T	Set of operating periods
Ω_B	Set of network buses
Ω_L	Set of transmission lines
Ω_G	Set of generating units
DV	Set of decision variables

Parameters

D	Annual discount rate
τ	Annuity factor
T	Assessment duration (years)
T_0	Base year
VOE	Value of emission (\$/ton)
E_G	Emission of generation technology G (ton/MWh)
$AV_{i,t}^W$	Available wind power generation at bus i at time t (MW)
$VOLL$	Value of loss of load (\$/MWh)
$VOWC$	Value of wind curtailment (\$/MWh)

ES_{min}	Minimum energy stored (MWh)
ES_{max}	Maximum energy stored (MWh)
$P_{i,max}^{dch}$	Maximum power discharged from ESS connected to bus i (MW)
$P_{i,max}^{ch}$	Maximum power charged to ESS connected to bus i (MW)
Λ_i^W	Capacity of Wind turbine installed in bus i (MW)
$\eta_{c/d}$	Charging/discharging efficiency of the energy storage unit
$\beta_{c/o}$	Critical/opportunistic percentage of increase/decrease of base cost in RA/RS approach (%)
$R_{c/o}$	Critical/opportunistic increase/decrease of base cost in RA/RS approach (\$)
Δ_t	Duration of time period t
$a_g/b_g/c_g$	Fuel cost coefficient of thermal unit g
$P_{i,t}^{D0}$	Active Power demand in bus i in time t (MWh)
$P_g^{max/min}$	Maximum/minimum limit of power generation of g^{th} thermal unit (MWh)
P_ℓ^{max}	Maximum allowed power limit of transmission line ℓ (MWh)
$\bar{P}_{i,t}^W$	Predicted power produced by wind turbine unit at bus i in time t (MW)
RU_g/RD_g	Ramp-up/down limit of power generation of g^{th} thermal unit (MW/h)
$P_{i,t}^W$	Uncertain power produced by wind turbine unit at bus i in time t (MW)

Variables

$\bar{P}_{i,t}^W$	Actual injected power produced by wind turbine unit at bus i in time t (MW)
$P_{i,t}^L$	Active Power demand in bus i in time t
f_b	Base cost when no uncertainty exists in problem (\$)
$P_{i,t}^{C_w}$	Curtailed power of wind turbine unit w connected to bus i in time t (MW)
$\Delta^{W+/-}$	Excess/shortage Power produced by wind turbine (compared to predicted one) connected to bus i in time t (MW)
OF	Objective function
$OC(t)$	Operating (fuel) cost of thermal units at time t
$P_{i,t}^G$	Power produced by thermal unit g in time t (MW)
$P_{\ell,t}$	Power flow in line ℓ in time t (MW)
α	Radius of uncertainty (%)
TC	Total costs (\$)
$\delta_{i,t}$	Voltage angle in bus i at time t (Radian)
$ES_{i,t}$	Energy stored in ESS connected to bus i at time t (MWh)
$P_{i,t}^{dch}$	Power discharged from ESS connected to bus i at time t (MW)
$P_{i,t}^{ch}$	Power charged in bus to ESS connected to bus i at time t (MW)
$I_{i,t}^{dch}$	Binary variable indicating the discharge state of ESS connected to bus i at time t
$I_{i,t}^{ch}$	Binary variable indicating the charge state of ESS connected to bus i at time t
$LS(i, t)$	Load shedding at bus i at time t (MW)
$LSC(t)$	Load shedding costs at time t (\$/MWh)

P. Maghouli is with the Department of Electrical Engineering, Shahed University, Tehran, Iran, (e-mail: p.maghouli@shahed.ac.ir)

Alireza Soroudi and Andrew Keane are with the School of Electrical, Electronic and Communications Engineering, University College Dublin, (e-mail: alireza.soroudi@ucd.ie, andrew.keane@ucd.ie)

$WC(t, i)$ Wind power curtailment at bus i at time t (MW)
 $WCC(t)$ Wind power curtailment costs at time t (\$/MWh)

I. INTRODUCTION

A. Background and motivations

Many countries have long term plans to increase the share of renewable energy resources in their generation mix. Among these renewable resources there has been increasing interest to invest and integrate more wind power in to existing power systems. However, increasing the wind penetration introduces profound challenges to traditional operating and planning practices. These new challenges arise mainly because of the variable nature of wind energy which results in none optimal operation of electric power systems. Traditionally it is accepted that electricity supply and consumption must remain in instantaneous balance the opportunity to store electrical energy in storage devices may now change this paradigm. Wind power intermittency and variability requires other fast ramping power sources to balance the supply-demand equilibrium in power systems [1]. Because of limiting capacity of fast ramping generation technologies such as hydro and pumped storage power plants, significant integration of wind power to existing power infrastructure requires major system upgrades or implementing energy storage facilities [2]. Besides, using energy storage facilities will result in more utilization of existing assets and thus attains more interest in recent studies [3] and become an attractive candidate for capturing wind power variability. Many studies assess the economic impact of storage devices in short term power system operation [2], [4], while deciding on energy storage deployment requires long term assessments especially when it is considered as an option for deferral of system reinforcement projects. Also a much harder challenge concerns planning of future energy systems with large intermittent resources [1]. Other studies operate storage devices optimally when they are combined or located close to wind farms [5]. Long term economical and system wide assessment of implementing energy storage systems are presented in [6], [7] without addressing transmission system capacity constraints. Storage devices can charge in low (locational marginal prices) LMPs and discharge at higher ones in a transmission network and thus provide a path for power flow from one time (when a line is congested) to the next at a same location [8] so can behave as an additional transfer capacity in a power network. This capability to shift the power transfer through the network is the major and unique advantage of storage devices in contrast to other measures (such as FACTS devices) taken for utilizing existing grid infrastructures more efficiently. A long term in depth analysis of storage devices is presented in [3] but the wind generation and effect of its uncertain power production is not addressed. Different grid scale storage technologies are discussed and the effect of energy storage devices on increasing the transfer capacity of power grid is addressed. In [9] the storage deployment problem is combined with transmission expansion planning problem without considering wind power generation and uncertainties. A three stage allocation of energy storage devices is proposed in [10] based on analyzing system operational

costs for one year with probabilistic wind generation data. A multi-objective framework is presented in [11] with analyzing system operational costs and voltage improvements under limited number of scenarios for wind generation. In [8] a long term assessment method is proposed and wind generation uncertainty treated by a probabilistic method. Different time slices with known probabilities are defined for capturing different realization of future wind generation. While probabilistic and stochastic methods are powerful tools in short term assessments, in long term studies the probabilities and PDFs could not be estimated with an acceptable error and more robust techniques should be utilized in these studies. The works proposed in the area of economic assessment of grid-scale energy storage systems can be classified as short term assessment methods such as [2], [4] (usually one day of operation) and long term (usually one year analysis or mid term) assessment methods such as [3], [6] and [7]. while as mentioned above, in the second category, i.e. long term studies, some works did not address transmission constraints (such as [7]), some did not address uncertainties (such as [3]) or both (such as [7]). Also, different storage technologies are addressed in these works while their model might be extended for other technologies.

Implementation of energy storage can improve power system performance in a variety of ways [12]. Improving dynamic stability [13], transient voltage dips, dynamic voltage stability [14], energy and ancillary service market performance [15], power quality [16], etc. are some of these improvements. Thus the decision on siting and sizing these devices should be made utilizing a multiple criteria decision making process with static and dynamic short and long term studies. In this paper, a robust computational framework is proposed for midterm assessment of storage devices in power networks considering their effect on power system operation with a mixed conventional-wind generation capacity. The wind integration in power systems may change the congestion pattern in a power grid and consequently LMPs. Also their variability imposes a huge burden on fast ramping power plants, thus the effect of storage devices is assessed by hourly optimization considering transmission system constraints with DC lossless model as usually used in transmission expansion planning studies [17]. The uncertainty of wind generation is modeled using the Information Gap Decision Theory (IGDT) [18], a powerful and robust technique for dealing uncertain parameters in long term studies [19]. Finally, a decision making framework is proposed for deciding on different storage deployment alternatives in the grid based on their benefits and robustness of this benefit.

B. Contributions

The main contributions of this work can be summarized as follows:

- A general multi criteria decision making process is proposed for evaluating energy storage deployment in transmission networks
- A dynamic multi-period optimal power flow model is proposed for exploring technical and economical benefits

of energy storage systems based on a linear optimization model

- A robust uncertainty modeling for wind generation is proposed for handling severe wind uncertainties in midterm studies

C. Paper Organization

This paper is set out as follows: the system and market model are presented in section II. The wind power generation uncertainty modeling are presented in section III. Simulation results on IEEE 24 bus standard test case [and modified IEEE 118 bus test system](#) are presented in section IV followed by concluding remarks and future works discussed in section V.

II. PROPOSED MODEL

Any transmission constraints or bottlenecks in transmission system could prevent perfect utilization of wind resources. Transmission network limitations are an almost universal impediment to the rapid deployment of wind capacity [20]. The transmission grids are designed and planned without considering wind power variability and intermittency. The conventional approach to relieve transmission constraints relies mainly on transmission reinforcement by constructing new transmission lines or upgrading existing ones with long construction times and considerable environmental effects [21]. Relying only on these conventional approaches may result in an over conservative transmission grid investments. Besides, shorter construction lead time of storage devices in contrast to transmission lines and their scalability and modular structure makes storage devices an attractive alternative approach for managing transmission constraints raised from rapid integration of wind power. Different approaches for transmission congestion management have been proposed in the literature while here the Standard Market Design paradigm is selected [22], [23].

[A multi-period dynamic optimal power flow is defined with ramping constraints seeking to minimize conventional generation operational costs, load shedding, wind curtailment and](#)

[environmental costs as hourly social costs \(HSC\):](#)

$$HSC(t) = OC(t) + LSC(t) + WCC(t) + EC(t) \quad (1)$$

$$OC(t) = \sum_{g=1}^{n_g} a_g (P_{i,t}^G)^2 + b_g P_{i,t}^G + c_g \quad (2)$$

$$LSC(t) = \sum_i LS(i, t) \times VOLL \quad (3)$$

$$WCC(t) = \sum_i WC(i, t) \times VOWC \quad (4)$$

$$EC(t) = \sum_i \sum_{g=1}^{n_g} VOE \times E_G \times P_{i,t}^G \quad (5)$$

$$P_g^{min} \leq P_{i,t}^G \leq P_g^{max} \quad (6)$$

$$P_{i,t+1}^G - P_{i,t}^G \leq RU_g \quad (7)$$

$$P_{i,t}^G - P_{i,t+1}^G \leq RD_g \quad (8)$$

$$f_{ij,t} - \frac{1}{X_{ij}} (\delta_{i,t} - \delta_{j,t}) = 0 \quad (9)$$

$$|f_{ij,t}| \leq P_\ell^{max} \quad (10)$$

$$\sum_j f_{ij,t} + \sum_{g=1}^{n_g} P_{i,t}^G + P_{i,t}^W + P_{i,t}^{dch} - P_{i,t}^{ch} + LS(i, t) = P_{i,t}^{D0} \quad (11)$$

$$LS(i, t) + P_{i,t}^d = P_{i,t}^{D0} \quad (12)$$

$$WC(i, t) + P_{i,t}^W = AV_{i,t}^W \quad (13)$$

The wind curtailment costs ($WCC(t)$) are calculated in (4). The environmental pollution costs associated with thermal units are calculated in (5). As mentioned earlier, here a lossless DCOPF model is adopted for midterm assessment. Equation (6) is the constraint defining the operational range of generators. The conventional generators' ramp rate constraints are modeled and considered in this study as (7) to (8). Equations (9) to (11) represents transmission network constraints. Wind power can be treated as a decision variable or as a must-take negative load. The load shedding costs ($LSC(t)$) are calculated in (3). The available wind power ($AV_{i,t}^W$) limits the summation of curtailed wind generation ($WC(i, t)$) plus the injected wind power ($P_{i,t}^W$) as stated in (13). In this study wind generation is modeled as a negative load while wind curtailment is allowed when there is not any feasible solution for system operation [or when wind curtailment cost is lower than the conventional generation re-dispatch costs](#). The generation costs of wind and storage plants are assumed to be negligible while their costs could be easily included in the objective.

A. Storage device model

Energy storage technologies such as pumped hydro, compressed air energy storage (CAES), various types of batteries, flywheels, electrochemical capacitors, etc., provide for multiple applications: energy management, backup power, load leveling, frequency regulation, voltage support, and grid stabilization [24]. Since storage can be a critical component of grid stability and resiliency, modernizing the grid will

require a substantial deployment of energy storage. Besides, technological developments make grid scale storage devices available especially in the form of CAES and various types of batteries [3], [25]. For these grid scale energy technologies, regulatory policies and rules provide the framework for the business case and economics of storage systems [24]. It is assumed that energy storage devices are centrally operated by the system operator and modeled as price takers [26]. Due to their limited capacity, their operation will not change market prices. The following constraints are used for defining energy storage charge and discharge behaviour [27]:

$$ES_{i,t} = ES_{i,t-1} + (P_{i,t}^{ch}\eta_c - P_{i,t}^{dch}/\eta_d)\Delta t \quad (14a)$$

$$ES_{min} \leq ES_{i,t} \leq ES_{max} \quad (14b)$$

$$P_{i,t}^{ch} \leq P_{i,max}^{ch} I_{i,t}^{ch} \quad (14c)$$

$$P_{i,t}^{dch} \leq P_{i,max}^{dch} I_{i,t}^{dch} \quad (14d)$$

$$I_{i,t}^{ch} + I_{i,t}^{dch} \leq 1 \quad (14e)$$

Note that storage devices are not allowed to charge or discharge intra-hour. At each hour (t) they are considered as effective generation or load [8] in equation (11). Any other operational constraints depending on storage technologies could be included in equation (14) while here a general framework is applied. Also a constraint on charge level at the end of each cycle (one day or week) could be easily incorporated in the formulation.

B. Objective function

Equation (15) with constraints proposed in equations (1) to (14) defines hourly system operation strategy aiming to maximize system social welfare. The effect of storage devices on system operation and social costs are assessed by hourly optimization of (1) in each day over a midterm horizon (typically one year) since a suitable evaluation method should accurately address both short term and long term benefits of storage devices. This approach obviously leads to a large computational burden but in planning studies, this is not the main concern. Storage devices are modeled as price-takers in this study and long term wind generation uncertainty is modeled by IGDT. Yearly system cost/ social welfare is minimized/ maximized by calculation of HSC over the planning horizon with a defined certainty level:

$$OF = \min_{DV} \sum_{t_y \in T} \frac{1}{(1+D)^{(t_y-T_0)}} \sum_t [HSC(t)] \quad (15)$$

Subject to :

(1) to (14)

The objective function of (15) includes power generation cost, load shedding cost, wind curtailment cost and environmental costs. Note that the construction cost of storage devices and transmission reinforcement projects could be easily added to (15). But we believe that deciding on where to construct a storage plant and its optimal size should be made with multiple criteria or attribute decision making process (MCDM/

MADM) by considering the effect of uncertainty on their economic viability. The most benefits of storage devices lies in their dynamic performance and thus a detailed dynamic and reliability study should be accompanied with static energy and ancillary service market analysis to select the best location and size of storage plants. The focus of this paper is to propose a framework for risk averse evaluating storage plants with midterm perspective for deferring or even omitting transmission system reinforcement plans and extending operational life of over-stressed existing equipment while other potential grid services of storage units are not addressed but could be easily included in the final decision making process.

III. PROPOSED IGDT FORMULATION

There are uncertain parameters in the objective function proposed in (15) among them wind generation uncertainty may has the most sever effect. Probabilistic based methods are applied for modeling wind generation uncertainty in planning studies [28]. However, for long term evaluating of storage projects, estimated benefits of their deployment should be obtained with an acceptable level of certainty. The Information Gap Decision Theory (IGDT) [19] tries to find the optimal set of DV to maximize the robustness of the objective function against the uncertainty input parameters [29]. It has been used in various applications such as electricity retailer energy selling strategy [30], generation asset allocation [31], transmission expansion planning [32] and GenCo's Trading Portfolio [33] and Distribution network restoration [34]. An optimization problem could generally be defined as follows:

$$f_b = \min_X f(DV, \Psi) \quad (16a)$$

$$H(X, \Psi) \leq 0, G(DV, \Psi) = 0 \quad (16b)$$

where DV is the set of decision variables and Ψ represent the input parameters. f_b is the base value of objective function when Ψ is equal to its predicted value.

In realistic applications, the Ψ is subject to uncertainty i.e. wind generation in proposed model. It is also assumed that no probability density function nor a fuzzy membership function is available for Ψ . It is assumed that all possible realizations of Ψ will be within an uncertainty set $U(\alpha, \bar{\Psi})$ described as follows:

$$\Psi \in U(\alpha, \bar{\Psi}) = \left\{ \Psi : \left| \frac{\Psi - \bar{\Psi}}{\bar{\Psi}} \right| \leq \alpha \right\} \quad (17)$$

$\bar{\Psi}$ is the predicted value of Ψ and α is called the radius of uncertainty and it is uncertain itself.

If $\Psi \in U(\alpha, \bar{\Psi})$ then two questions arise here as follows:

- What is the maximum value of α if the decision variable DV is applied to the system and the deterioration of objective function is limited to β_c percent of f_b ? Is it possible to increase it ?
- What is the minimum value of α if the decision variable DV is applied to the system and the improvement of objective function is expected to be β_o percent of f_b ? Is it possible to decrease it ?

The IGDT modeling answers these two questions using three important terms as follows:

- Uncertainty modeling : this term, describes the uncertainty set which uncertain parameter belongs to. This set is also uncertain.
- Risk Averse Strategy (RA): In this strategy, the decision maker tries to find the optimal decision variables in such a way that for any materialization of the uncertain parameter (within the uncertainty set), the objective function will always remain within some bounds specified by the decision maker. These bounds specify the tolerance level of decision maker regarding the deterioration of objective function. It is tried to make the objective function robust against the uncertainty.
- Risk Seeker Strategy (RS): In this strategy, the decision maker tries to find the optimal decision variables in such a way that the chance of having better solutions compared to base case (no uncertainty) is increased. It is tried to maximize the chance of reaching to good solutions in presence of uncertainties.

Each term is described in the following sections for the proposed method in this study.

A. Wind power generation uncertainty modeling

The uncertain parameter in this work is assumed to be wind power generation $P_{i,t}^W$ in (11). It is assumed that this parameter is subject to severe uncertainty and there is no probability density function (PDF) nor membership function is in hand for this quantity. The only available data is the predicted value of wind $\bar{P}_{i,t}^W$ (which is definitely not precise). It is assumed that $P_{i,t}^W$ belongs to an uncertainty set like $U(\alpha, \bar{P}_{i,t}^W)$ which is described as follows:

$$P_{i,t}^W \in U(\alpha, \bar{P}_{i,t}^W) = \left\{ P_{i,t}^W : \left| \frac{P_{i,t}^W - \bar{P}_{i,t}^W}{\bar{P}_{i,t}^W} \right| \leq \alpha \right\} \quad (18)$$

$$0 \leq \alpha \quad (19)$$

The α is called the radius of uncertainty which is also uncertain.

The relation between the predicted wind power ($\bar{P}_{i,t}^W$) and the uncertain wind power ($P_{i,t}^W$) is described in (20).

$$P_{i,t}^W = \bar{P}_{i,t}^W + \Delta_{i,t}^{W+} - \Delta_{i,t}^{W-} \quad (20)$$

According to (20), there are three possibilities as follows :

- The actual wind is less than predicted one then $\Delta_{i,t}^{W+} = 0, \Delta_{i,t}^{W-} > 0$
- The actual wind is more than predicted one then $\Delta_{i,t}^{W+} > 0, \Delta_{i,t}^{W-} = 0$
- The actual wind is equal to predicted one then $\Delta_{i,t}^{W+} = 0, \Delta_{i,t}^{W-} = 0$

The positive and negative deviations are bounded as specified in IGDT uncertainty set ($U(\alpha, P_{i,t}^W)$) so the following relations holds:

$$\Delta_{i,t}^{W\pm} \leq \bar{P}_{i,t}^W \alpha \quad (21)$$

The excessive wind generation (compared to the predicted one) is limited by the installed capacity of wind in bus i (22).

$$\Delta_{i,t}^{W+} \leq \Lambda_i^W - \bar{P}_{i,t}^W \quad (22)$$

B. Risk Averse Strategy (RA)

In this strategy, the decision maker tries to find the largest uncertainty at which the failure (exceeding the tolerable deterioration) does not happen. The decisions are made to maximize this uncertainty (degree of robustness). It is described as a bi-level optimization as follows:

- 1) The base case scenario is solved:

$$f_b = \min_{DV} OF \quad (23a)$$

$$\alpha = 0 \quad (23b)$$

Subject to :

- (1) to (22)

The base value of objective function (f_b) is the value of OF when there is no prediction error for uncertain wind power ($P_{i,t}^W = \bar{P}_{i,t}^W$).

- 2) The second step of the algorithm finds the worst case of α that the objective function (for a given set of decision variables) always remains less than a critical level $\Delta_c \geq f_b$?. This involves solving a bi-level optimization. In lower level (LL) for a given DV it finds the α that the maximum value of OF remains less than a predefined threshold Δ_c . The UL tries to maximize this α value by setting the appropriate DV.

$$UL : \hat{\alpha}(DV, \bar{P}_{i,t}^W) = \max_{DV} \alpha \quad (24a)$$

$$LL : \max_{P_{i,t}^W} OF(DV, P_{i,t}^W) \leq \Delta_c \quad (24b)$$

$$P_{i,t}^W \in U(\alpha, \bar{P}_{i,t}^W) \quad (24c)$$

$$\Delta_c = (1 + \beta_c) f_b \quad (24d)$$

$$0 \leq \beta_c \leq 1 \quad (24e)$$

Subject to :

- (1) to (22)

The value of β_c is set by the decision maker based on its toleration level. Considering the wind uncertainty set $U(\alpha, \bar{P}_{i,t}^W)$, the solution of lower level is trivial and it is $P_{i,t}^W = (1 - \alpha)\bar{P}_{i,t}^W$. The bi-level optimization described in (24) would change into a single level one as follows:

$$\hat{\alpha}(DV, \bar{P}_{i,t}^W) = \max_{DV, \alpha} \alpha \quad (25a)$$

$$OF(DV, P_{i,t}^W) \leq \Delta_c \quad (25b)$$

$$P_{i,t}^W \leq (1 - \alpha)\bar{P}_{i,t}^W \quad (25c)$$

$$\Delta_c = (1 + \beta_c) f_b \quad (25d)$$

$$0 \leq \beta_c \leq 1 \quad (25e)$$

Subject to :

- (1) to (22)

The outcome of (25) gives the DV set. It is interpreted as follows: If the decision maker follows the DV pattern, then he can be sure that the objective function is robust against the uncertainties (to β_c %) as far as wind uncertainties are below $\hat{\alpha}$.

C. Risk Seeker Strategy (RS)

In this strategy, the decision maker tries to find the best decision in a way that sweeping success would be possible with the least chance. It is described as a bi-level optimization as follows:

- 1) The base case scenario is solved the same as (23).
- 2) The second step of the algorithm finds the minimum required α that the objective function (for a given DV) can be less than a opportunistic level $R_o \leq f_b$?. This involves solving a bi-level optimization. In lower level (LL) for a given DV it finds the α that the minimum value of OF remains less than a predefined threshold R_o . The Upper level tries to minimize this α value by finding the optimal DV .

$$UL : \check{\alpha}(DV, \bar{P}_{i,t}^W) = \min_{DV} \alpha \quad (26a)$$

$$LL : \min_{P_{i,t}^W} OF(DV, P_{i,t}^W) \leq R_o \quad (26b)$$

$$P_{i,t}^W \in U(\alpha, \bar{P}_{i,t}^W) \quad (26c)$$

$$\Delta_c = (1 - \beta_o) f_b \quad (26d)$$

$$0 \leq \beta_o \leq 1 \quad (26e)$$

Subject to :

(1) to (22)

The value of β_o is set by the decision maker based on its desired reduction level. Considering the wind uncertainty set $U(\alpha, \bar{P}_{i,t}^W)$, the solution of lower level is trivial and it is $P_{i,t}^W = (1 + \alpha) \bar{P}_{i,t}^W$. The bi-level optimization described in (26) would change into a single level one as follows:

$$\check{\alpha}(DV, \bar{P}_{i,t}^W) = \min_{DV, \alpha} \alpha \quad (27a)$$

$$OF(DV, P_{i,t}^W) \leq R_o \quad (27b)$$

$$P_{i,t}^W \leq (1 + \alpha) \bar{P}_{i,t}^W \quad (27c)$$

$$\Delta_c = (1 - \beta_o) f_b \quad (27d)$$

$$0 \leq \beta_o \leq 1 \quad (27e)$$

Subject to :

(1) to (22)

The outcome of (27) gives the DV set. It is interpreted as follows: If the decision maker follows the DV pattern, then he can be hopeful that the objective function is able to reach (to β_o % less than f_b) as far as wind uncertainties are at least $\hat{\alpha}$.

IV. SIMULATION RESULT

A. Case-I: IEEE 24-bus RTS

The proposed model is applied to the IEEE 24 bus standard test case as depicted in Fig. 1 [26]. This network mainly

includes two areas with 230 kV and 138 kV sub-grids interconnected through power transformers. The base load of this system is 2850 MW and generation mix includes variety of conventional technologies with 3405 MW installed capacity [3]. The environmental costs are taken from [3]. The total load of the system increased by 10%, two new wind generations with 200 and 400 MW rated capacity are added on buses 17 and 20 respectively (about 20% wind penetration level) and the rated capacity of 230 kV/500 MVA lines are reduced to 400 MVA for more stressing the system while retaining original transmission network topology. The main power flow pattern in this network is from 230 kV area to 138 kV. Thus corridors interconnecting these two areas are more vulnerable to congestion. Different grid scale storage

TABLE I
THE NETWORK OPERATIONAL PERFORMANCE FOR EACH ALTERNATIVE
(CASE I:IEEE- 24 BUS)

Alternative	Location	Benefit/Cost	$\hat{\alpha}(RA)$	$\hat{\alpha}(RS)$	μ_C	μ_{RA}	μ_{RS}	min
1	12	1.1029	0.2154	0.2900	0.6672	0.4858	0.7395	0.4858
2	14	1.3749	0.1955	0.2661	1.0000	0.0000	1.0000	0.0000
3	24	0.7360	0.2318	0.2938	0.2181	0.8854	0.6983	0.2181
4	17	0.5578	0.2356	0.3039	0.0000	0.9783	0.5875	0.0000
5	20	0.8080	0.2284	0.2963	0.3062	0.8029	0.6703	0.3062
6	12, 14	1.0550	0.2024	0.2800	0.6085	0.1691	0.8479	0.1691
7	14, 24	1.0122	0.2079	0.2982	0.5562	0.3019	0.6505	0.3019
8	17, 20	0.6275	0.2335	0.3141	0.0853	0.9270	0.4770	0.0853
9	17, 14	0.9667	0.2169	0.3108	0.5004	0.5220	0.5127	0.5004
10	14, 20	1.0176	0.2086	0.3280	0.5628	0.3191	0.3255	0.3191
11	24, 12	0.8400	0.2307	0.2956	0.3454	0.8578	0.6779	0.3454
12	17, 24	0.5885	0.2360	0.3120	0.0375	0.9863	0.4992	0.0375
13	12, 17	0.7800	0.2316	0.3054	0.2719	0.8813	0.5716	0.2719
14	20, 24	0.6853	0.2328	0.3074	0.1561	0.9102	0.5493	0.1561
15	14, 17, 24	0.8091	0.2313	0.3244	0.3076	0.8740	0.3643	0.3076
16	14, 17, 20	0.8164	0.2325	0.3578	0.3164	0.9028	0.0000	0.0000
17	17, 20, 24	0.5692	0.2365	0.3231	0.0139	1.0000	0.3787	0.0139
18	12, 14, 20	0.8714	0.2136	0.3241	0.3838	0.4415	0.3672	0.3672

technologies are analyzed in [35]. In this study, advanced lead-acid batteries rated 50 MW/ 5 hours with 90% charge and discharge efficiency (i.e. 250 MWh with 81% round trip efficiency) are considered [3], [12] while the proposed formulation could be used for evaluating other technologies as well. It should be noted here that, both network congestion level and its duration have direct impacts on total system operational costs. The system is analyzed through one year of operation with the objective defined in equation (15) and the model implemented in GAMS software using CPLEX solver [36]. Wind data are obtained from [37] and wind curtailment cost is considered to be \$50/MWh [38]. **The VOLL is assumed to be \$10000/MWh.**

1) *Evaluating Alternatives:* Benefits of deploying storage devices could be estimated with a well-known index i.e. benefit to cost ratio according to their impact on system operational cost defined in (15). However; the actual benefits may be lower or higher than what is estimated for the known wind power forecast. The actual benefit function may be any function within a given uncertainty envelope. Applying the IGDT model, the robust and opportunist range of these benefits are explored. Fast response time of battery energy storage systems presents a wide range of benefits and flexibilities to power system, ranges from frequency regulation to stability and reliability improvements. Thus, the recovery cost of energy storage should be distributed over multiple revenue resources [39]. It is assumed that the system planner defines different alternatives for energy storage deployment in the grid

as presented in Table I considering different aspects of energy storage. For example, analysis shows that with increasing the wind penetration level to 20%, the system fast response frequency regulation demand increases from 1% to 7% of installed capacity [39]. The investment cost of each energy storage considered in this study is about 99.5 \$m (\$250/kwh for the battery, \$220/kw for the power conversion system and \$520/kw for balance of the system) and with life expectancy of 15 years [3]. Considering 5% annual discount rate, the annual investment cost will be 9.6 \$m. Here we define three criteria for evaluating alternatives presented in Table I i.e. benefit to cost ratio, robustness measure and opportuneness measure while other criteria could be easily included in the model. The benefit to cost ratio is defined as the ratio of total savings in system operational cost (defined in (15)) to annualized investment cost in storage systems and the annuity factor is defined as:

$$\tau = \frac{D(1+D)^n}{(1+D)^n - 1} \quad (28)$$

The decision maker (TSO) is faced with 18 different alternatives as described in Table I. In each alternative, the number of installed storage units as well as their location are specified. [Using the fuzzy satisfying method \[40\] \(see Appendix A\), the best alternative is the alternative 9, i.e. deploying storage devices on 14 and 17 buses.](#) This alternative is chosen as the best solution regarding the maximizing $\hat{\alpha}$ and minimizing $\hat{\alpha}$ and maximizing the benefit to cost ratio.

This result shows the benefits of system wide evaluation because deploying storage devices on wind farm buses resulted in lower operational cost savings. However in alternative #8 (storage on wind buses) there were be no any wind curtailment while in the selected alternative the system will experience a low level of wind curtailment. The risk measures presented in Table I shows that the selected alternative will tolerate about 21% uncertainty in wind power prediction in RA approach and 31% in RS approach as shown in Fig. 2. If wind is outside of the opportunistic region in Fig. 2 then the decision maker can be sure he can reach 3% decrease (RS) of base case cost. On the other hand, if wind is inside the robust region in Fig. 2 then the decision maker can be sure that the operating cost will not increase more than 3% of the base case cost.

These results also shows a long cost recovery time for investment in energy storage and also shows that deciding on these devices should be made with a multiple criteria approach. The proposed framework in this study should be easily extended to consider other benefits of energy storage systems. In the next section, their impact on system congestion is analyzed and reported for example.

2) *Deterministic analysis:* The proposed power system with assumptions made in previous section is analyzed considering deterministic wind data pattern i.e. without uncertainty. Fig. 3 shows load and wind profile for an arbitrary selected 4 days period in the study horizon. Without loss of generality, it is assumed that the wind profile for both wind farms located at buses 14 and 17 are the same. The system analyzed in two conditions: base case where there is not any storage

device in the system and the second one with two 250 MWh storage devices located on buses 14 and 17. Results which are summarized in Table II shows the system yearly operational cost in both cases based on the equation (15). The yearly system operational cost is decreased from \$295.10m down to \$276.54m which means the total annual saving in system operational costs results from deploying two storage devices is about \$18.56m. But here there is no uncertainty in wind forecasting while in long and midterm studies, wind power forecasting may have severe uncertainties.

TABLE II
THE RESULTS FOR TWO CASE STUDIES WITH AND WITHOUT STORAGE DEVICES, CASE-I

Case	TOC (m\$)	TCR (m\$)
Base case (no storage)	295.104	154.865
Two 250 MWh storage on buses 14 and 17	276.544	146.831

The system congestion rent is calculated based on LMP differences on transmission lines [41] (see Appendix B). Results depicted in Table I shows storage devices valuable benefits in reducing network congestion rents and consequently maximizing wind power utilization and also improving market efficiency. It should be noted here that system total congestion rents used here as an index of LMP flatness which means reducing bottlenecks and market competition level. The charging status of two considered storage devices at buses 14 and 17 are depicted in Fig. 4 and Fig. 5 corresponding to load and wind profile of Fig. 3.

From Fig. 4 and Fig. 5, it is clear that the behavior of storage device are depend both on load and wind profile and energy is stored in low LMPs and discharged to the network in higher ones taking into consideration energy devices operational constraints. A minimum level of charge is considered for storage devices because of their operational constraints and also providing a reserve margin for other usages. Any periodical charge status [constraint](#) could be considered in the study which depends on energy storage technology.

B. Case II: Modified IEEE 118 Bus System

The proposed model is also applied to the modified IEEE 118 bus test case [42]. This network mainly includes three interconnected areas, 54 conventional thermal units and 186 branches. The total load of the system increased by 10% and it is assumed that 400 MW wind generation plants are located on buses 89, 90, 100 and 103 in the third area. The wind and load profiles used in the IEEE 24 bus analysis are used here also and other simulation parameters (e.g. wind curtailment cost, battery capacities, interest rate and etc.) are the same as in the previous study. Locating wind generation power plants in the third area leads to inter and intra-area congestion in the network. Fourteen different alternatives are defined for battery energy storage deployment in this grid. The results of the system analysis for one year based on the proposed formulation and decision making process are presented in Table III. A comparison of Table III and I shows that here the benefit to cost ratios associated to the alternatives are

TABLE III
THE NETWORK OPERATIONAL PERFORMANCE FOR EACH ALTERNATIVE
(CASE II: IEEE- 118 BUS)

Alternative	Location	Benefit/Cost	$\hat{\alpha}(RA)$	$\hat{\alpha}(RS)$	μ_C	μ_{RA}	μ_{RS}	min
1	82,96	1.2828	0.1745	0.1161	0.7742	1.0000	0.9456	0.7742
2	96,118	1.4105	0.1632	0.1208	0.9446	0.8265	0.8757	0.8265
3	96, 98	1.4520	0.1580	0.1124	1.0000	0.7472	1.0000	0.7472
4	82,96,98	1.0880	0.1429	0.1232	0.5142	0.5154	0.8401	0.5142
5	96,98,100	1.1218	0.1377	0.1349	0.5593	0.4350	0.6677	0.4350
6	82,96,118	1.1092	0.1397	0.1138	0.5425	0.4656	0.9785	0.4656
7	96, 98, 118	1.1884	0.1286	0.1240	0.6482	0.2964	0.8283	0.2964
8	89,90,100,103	0.7029	0.1648	0.1801	0.0000	0.8510	0.0000	0.0000
9	82,96,100,118	0.9590	0.1165	0.1262	0.3419	0.1109	0.7953	0.1109
10	82,96,98,118	0.9719	0.1143	0.1235	0.3591	0.0765	0.8362	0.0765
11	80,82,98,118	0.9919	0.1108	0.1265	0.3858	0.0231	0.7907	0.0231
12	82,90,96,103	0.8841	0.1303	0.1332	0.2420	0.3218	0.6929	0.2420
13	96,98,100,118	0.9946	0.1093	0.1266	0.3895	0.0000	0.7894	0.0000
14	80,98,100,118	0.9443	0.1196	0.1334	0.3223	0.1574	0.6891	0.1574

generally higher. The higher benefit to cost ratios means that in a realistic network, the huge investment costs of battery energy storage systems might be justified. However, other revenue resources should also be considered. By applying the fuzzy satisfying method for decision making the second alternative is selected with respect to three defined criteria which mean deploying storage devices on buses 96 and 118. In this alternative storage devices are both located on buses (corridors) between the third and the second areas and also the second and the first areas. The charging status of storage devices in the second alternative are presented in Fig. 7 and 8 for four successive days with same load and wind profiles as in the IEEE 24 bus case study (Fig. 3). The Robustness and Opportuneness radius of uncertainty are plotted vs operating costs in Fig. 9.

V. CONCLUSION

Operational flexibility, modular structure and scalability and short construction lead time of storage devices make them an attractive option for future smart power grids with considerable wind power generation. In this paper a novel approach is proposed for assessing grid-scale energy storage devices deployment in power systems where they operated centrally by system operator. The uncertainty associated with intermittent wind generators are modeled by IGDT to obtain a robust estimation of energy storage system-wide benefits. Both risk averse and risk seeker approaches of info-gap theory are presented for exploring all possible outcomes. While the results show a considerable savings in system operational costs, other energy storage benefits should be considered for their feasibility. The major goal of this paper is to propose a robust model for evaluating energy storage device deployment in energy markets. However, in energy storage evaluating process, other benefits of storage devices should be addressed. In fact, because of large investment costs of storage deployment in the system, their necessity could not be justified by only analyzing the energy market and their other system wide advantages in ancillary system market, reliability performances, dynamic performances and etc. should be addressed which is considered for further development of the proposed approach. Also, for obtaining a set of candidate locations for storage deployment, a thorough static and dynamic analysis of the grid should be conducted for exploring bottlenecks of the grid. however, if these devices would be used for

deferring transmission reinforcement projects, power flow and congestion patterns of the grid reveals their probable candidate locations.

APPENDIX A FUZZY SATISFYING METHOD

For minimizing objective functions the fuzzy satisfying function is defined as follows [40]:

$$\mu_{f_k}(X_n) = \frac{f_k^{max} - f_k(X_n)}{f_k^{max} - f_k^{min}}, f_k^{min} \leq f_k(X_n) \leq f_k^{max} \quad (29)$$

In this work, the minimization function is Opportuneness degree ($\hat{\alpha}$).

For maximizing objective functions the fuzzy satisfying function is defined as follows:

$$\mu_{f_k}(X_n) = \frac{f_k(X_n) - f_k^{min}}{f_k^{max} - f_k^{min}}, f_k^{min} \leq f_k(X_n) \leq f_k^{max} \quad (30)$$

In this work, the maximization functions are robustness degree ($\hat{\alpha}$) and benefit to cost ratio. Once the membership degree of fuzzy satisfying is found for every solution regarding each objective function then the final solution is chosen as follows: A conservative decision maker tries to maximize minimum satisfaction among all objectives or minimize the maximum dissatisfaction. The final solution can then be found as:

$$\max_{n=1}^N (\min_{k=1}^{N_O} (\mu_{f_k}(X_n))) \quad (31)$$

It should be noted that this is a conservative approach while other decision making approaches could also be used such as minimizing the distance between the real and desired value of satisfaction [43].

APPENDIX B CONGESTION RENTS

The total system congestion rent is calculated as follows:

$$TCR = \sum_{i,j,t,y} f_{i,j,t}(\lambda_{j,t} - \lambda_{i,t}) \quad (32)$$

REFERENCES

- [1] L. Xie, P. Carvalho, L. Ferreira, J. Liu, B. Krogh, N. Popli, and M. Ilic, "Wind integration in power systems: Operational challenges and possible solutions," *Proceedings of the IEEE*, vol. 99, no. 1, pp. 214–232, Jan 2011.
- [2] A. Papavasiliou, S. Oren, and R. O'Neill, "Reserve requirements for wind power integration: A scenario-based stochastic programming framework," *IEEE Transactions on Power Systems*, vol. 26, no. 4, pp. 2197–2206, Nov 2011.
- [3] A. Del Rosso and S. Eckroad, "Energy storage for relief of transmission congestion," *Smart Grid, IEEE Transactions on*, vol. 5, no. 2, pp. 1138–1146, March 2014.
- [4] N. Li and K. Hedman, "Economic assessment of energy storage in systems with high levels of renewable resources," *IEEE Transactions on Sustainable Energy*, vol. 6, no. 3, pp. 1103–1111, July 2015.
- [5] J. Garcia-Gonzalez, R. de la Muela, L. Santos, and A. Gonzalez, "Stochastic joint optimization of wind generation and pumped-storage units in an electricity market," *IEEE Transactions on Power Systems*, vol. 23, no. 2, pp. 460–468, May 2008.

- [6] A. Foley, P. Leahy, K. Li, E. McKeogh, and A. Morrison, "A long-term analysis of pumped hydro storage to firm wind power," *Applied Energy*, vol. 137, no. 0, pp. 638–648, 2015.
- [7] B. Cleary, A. Duffy, A. O'Connor, M. Conlon, and V. Fthenakis, "Assessing the economic benefits of compressed air energy storage for mitigating wind curtailment," *IEEE Transactions on Sustainable Energy*, vol. 6, no. 3, pp. 1021–1028, July 2015.
- [8] H. Oh, "Optimal planning to include storage devices in power systems," *IEEE Transactions on Power Systems*, vol. 26, no. 3, pp. 1118–1128, Aug 2011.
- [9] F. Zhang, Z. Hu, and Y. Song, "Mixed-integer linear model for transmission expansion planning with line losses and energy storage systems," *Generation, Transmission Distribution, IET*, vol. 7, no. 8, pp. 919–928, Aug 2013.
- [10] H. Pandzic, Y. Wang, T. Qiu, Y. Dvorkin, and D. Kirschen, "Near-optimal method for siting and sizing of distributed storage in a transmission network," *IEEE Transactions on Power Systems*, vol. PP, no. 99, pp. 1–13, 2014.
- [11] S. Wen, H. Lan, Q. Fu, D. Yu, and L. Zhang, "Economic allocation for energy storage system considering wind power distribution," *IEEE Transactions on Power Systems*, vol. 30, no. 2, pp. 644–652, March 2015.
- [12] D. Rastler, *Electricity energy storage technology options: a white paper primer on applications, costs and benefits*. Electric Power Research Institute, 2010.
- [13] L. Wang, J.-Y. Yu, and Y.-T. Chen, "Dynamic stability improvement of an integrated offshore wind and marine-current farm using a flywheel energy-storage system," *Renewable Power Generation, IET*, vol. 5, no. 5, pp. 387–396, September 2011.
- [14] V. Bolborici, F. Dawson, and K. Lian, "Hybrid energy storage systems: Connecting batteries in parallel with ultracapacitors for higher power density," *Industry Applications Magazine, IEEE*, vol. 20, no. 4, pp. 31–40, July 2014.
- [15] B. Olek and M. Wierzbowski, "Local energy balancing and ancillary services in low-voltage networks with distributed generation, energy storage, and active loads," *Industrial Electronics, IEEE Transactions on*, vol. 62, no. 4, pp. 2499–2508, April 2015.
- [16] I. Wasiak, R. Pawelek, and R. Mienski, "Energy storage application in low-voltage microgrids for energy management and power quality improvement," *Generation, Transmission Distribution, IET*, vol. 8, no. 3, pp. 463–472, March 2014.
- [17] P. Maghouli, S. Hosseini, M. Buygi, and M. Shahidehpour, "A scenario-based multi-objective model for multi-stage transmission expansion planning," *IEEE Transactions on Power Systems*, vol. 26, no. 1, pp. 470–478, Feb 2011.
- [18] A. Rabiee, A. Soroudi, and A. Keane, "Information gap decision theory based opf with hvdc connected wind farms," *IEEE Transactions on Power Systems*, vol. PP, no. 99, pp. 1–11, 2014.
- [19] Y. Ben-Haim, *Info-gap decision theory: decisions under severe uncertainty*. Academic Press, 2006.
- [20] Y. Gu, J. McCalley, and M. Ni, "Coordinating large-scale wind integration and transmission planning," *IEEE Transactions on Sustainable Energy*, vol. 3, no. 4, pp. 652–659, Oct 2012.
- [21] P. Maghouli, S. Hosseini, M. Buygi, and M. Shahidehpour, "A multi-objective framework for transmission expansion planning in deregulated environments," *IEEE Transactions on Power Systems*, vol. 24, no. 2, pp. 1051–1061, May 2009.
- [22] R. O'Neill, U. Helman, R. Baldick, J. Stewart, W.R., and M. Rothkopf, "Contingent transmission rights in the standard market design," *IEEE Transactions on Power Systems*, vol. 18, no. 4, pp. 1331–1337, Nov 2003.
- [23] G. Shrestha and P. Fonseka, "Optimal transmission expansion under different market structures," *Generation, Transmission Distribution, IET*, vol. 1, no. 5, pp. 697–706, September 2007.
- [24] <http://goo.gl/xWb8Km>, "Grid energy storage," US department of energy, Tech. Rep., December 2013.
- [25] D. Swider, "Compressed air energy storage in an electricity system with significant wind power generation," *Energy Conversion, IEEE Transactions on*, vol. 22, no. 1, pp. 95–102, March 2007.
- [26] H. Akhavan-Hejazi and H. Mohsenian-Rad, "Optimal operation of independent storage systems in energy and reserve markets with high wind penetration," *Smart Grid, IEEE Transactions on*, vol. 5, no. 2, pp. 1088–1097, March 2014.
- [27] L. Vargas, G. Bustos-Turu, and F. Larrain, "Wind power curtailment and energy storage in transmission congestion management considering power plants ramp rates," *IEEE Transactions on Power Systems*, vol. PP, no. 99, pp. 1–9, 2014.
- [28] A. Soroudi and M. Afrasiab, "Binary pso-based dynamic multi-objective model for distributed generation planning under uncertainty," *IET renewable power generation*, vol. 6, no. 2, pp. 67–78, 2012.
- [29] A. Soroudi and T. Amraee, "Decision making under uncertainty in energy systems: state of the art," *Renewable and Sustainable Energy Reviews*, vol. 28, pp. 376–384, 2013.
- [30] M. Charwand and Z. Moshavash, "Midterm decision-making framework for an electricity retailer based on information gap decision theory," *International Journal of Electrical Power & Energy Systems*, vol. 63, pp. 185–195, 2014.
- [31] Y. Zhao and S. Zhang, "Application of information-gap decision theory to generation asset allocation," in *Intelligent Computing in Smart Grid and Electrical Vehicles*. Springer, 2014, pp. 398–408.
- [32] S. Sarhadi and T. Amraee, "Robust dynamic network expansion planning considering load uncertainty," *International Journal of Electrical Power & Energy Systems*, vol. 71, no. 0, pp. 140–150, 2015.
- [33] P. Mathuria and R. Bhakar, "Info-gap approach to manage genco's trading portfolio with uncertain market returns," *IEEE Transactions on Power Systems*, vol. 29, no. 6, pp. 2916–2925, Nov 2014.
- [34] K. Chen, W. Wu, B. Zhang, and H. Sun, "Robust restoration decision-making model for distribution networks based on information gap decision theory," *Smart Grid, IEEE Transactions on*, vol. PP, no. 99, pp. 1–1, 2014.
- [35] A. A. Akhil, G. Huff, A. B. Currier, B. C. Kaun, D. M. Rastler, S. B. Chen, A. L. Cotter, D. T. Bradshaw, and W. D. Gauntlett, "Doe/epri 2013 electricity storage handbook in collaboration with nreca," ed: *Albuquerque, NM: Sandia National Laboratories*, 2013.
- [36] A. M. A. Brooke, D. Kendrick and R. Raman, *GAMS/Cplex 7.0 User Notes*. GAMS Development Corp., 2000.
- [37] Eirgrid, "Irish transmission system operator (tso)," Accessed 01/01/2014. [Online]. Available: <http://www.eirgrid.com/operations/systemperformancedata/systemdemand/>
- [38] H. Park and R. Baldick, "Transmission planning under uncertainties of wind and load: Sequential approximation approach," *IEEE Transactions on Power Systems*, vol. 28, no. 3, pp. 2395–2402, Aug 2013.
- [39] B. McKeon, J. Furukawa, and S. Fenstermacher, "Advanced lead acid batteries and the development of grid-scale energy storage systems," *Proceedings of the IEEE*, vol. 102, no. 6, pp. 951–963, June 2014.
- [40] A. Soroudi, M. Ehsan, R. Caire, and N. Hadjsaid, "Hybrid immune-genetic algorithm method for benefit maximisation of distribution network operators and distributed generation owners in a deregulated environment," *Generation, Transmission Distribution, IET*, vol. 5, no. 9, pp. 961–972, September 2011.
- [41] R. Baldick, "Border flow rights and contracts for differences of differences: Models for electric transmission property rights," *IEEE Transactions on Power Systems*, vol. 22, no. 4, pp. 1495–1506, Nov 2007.
- [42] Motor.ece.iit.edu/data/IEAS-IEEE118.doc.
- [43] A. Charnes and W. W. Cooper, "Goal programming and multiple objective optimizations: Part 1," *European Journal of Operational Research*, vol. 1, no. 1, pp. 39–54, 1977.

List of figure captions :

- IEEE 24 bus standard test case
- The robust and opportunistic wind generation regions, Case I
- Demand and wind power profile vs time in four days in the study period
- Charging status of energy storage device located at bus 17 (RA/RS, $\beta_{c/o} = 3\%$), Case I
- Charging status of energy storage device located at bus 14 (RA/RS, $\beta_{c/o} = 3\%$), Case I
- Robustness and Opportuneness vs operating cost, Case I
- Charging status of energy storage device located at bus 96 (RA/RS, $\beta_{c/o} = 3\%$), Case II
- Charging status of energy storage device located at bus 118 (RA/RS, $\beta_{c/o} = 3\%$), Case II
- Robustness and Opportuneness vs operating cost, Case II

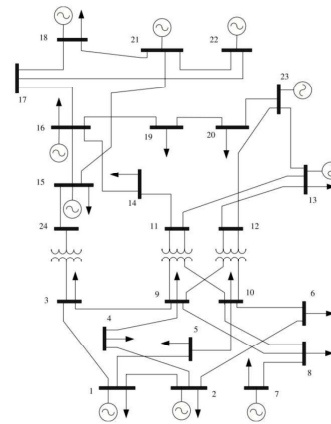

Fig. 1. IEEE 24 bus standard test case

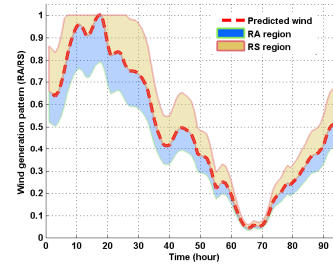

Fig. 2. The robust and opportunistic wind generation regions, Case I

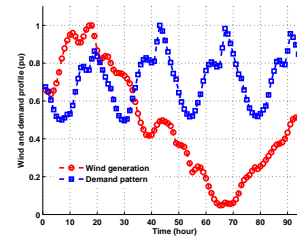

Fig. 3. Demand and wind power profile vs time in four days in the study period, Case I

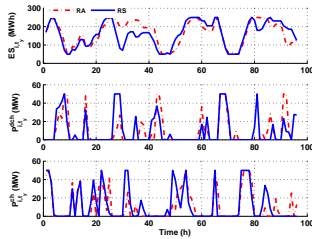

Fig. 4. Charging status of energy storage device located at bus 17 (RA/RS, $\beta_{c/o} = 3\%$), Case I

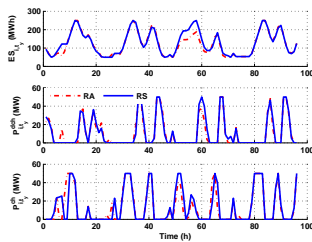

Fig. 5. Charging status of energy storage device located at bus 14 (RA/RS, $\beta_{c/o} = 3\%$), Case I

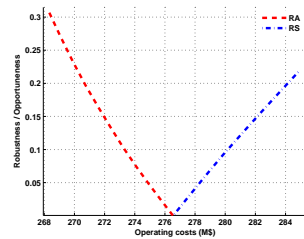

Fig. 6. Robustness and Opportuneness vs operating cost, Case I

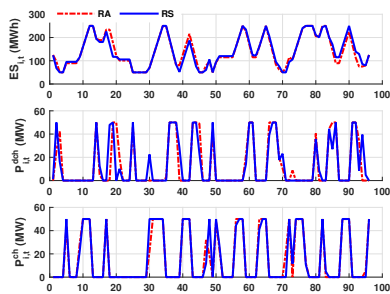

Fig. 7. Charging status of energy storage device located at bus 96, (RA/RS, $\beta_{c/o} = 3\%$), Case II

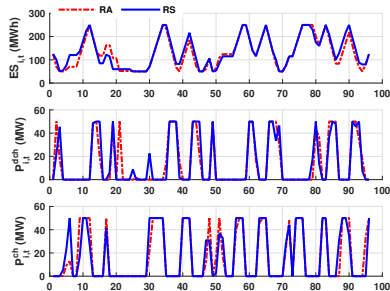

Fig. 8. Charging status of energy storage device located at bus 118 (RA/RS, $\beta_{c/o} = 3\%$), Case II

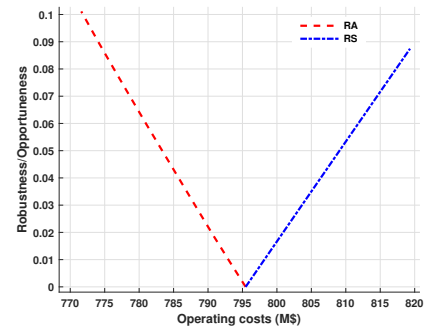

Fig. 9. Robustness and Opportuneness vs operating cost, Case II