



Title	Biologicalisation: Biological Transformation in Manufacturing
Authors(s)	Byrne, Gerald, Dimitrov, Dimitri, Monostori, Laszlo, et al.
Publication date	2018-05
Publication information	Byrne, Gerald, Dimitri Dimitrov, Laszlo Monostori, and et al. "Biologicalisation: Biological Transformation in Manufacturing." Elsevier, May 2018. https://doi.org/10.1016/j.cirpj.2018.03.003 .
Publisher	Elsevier
Item record/more information	http://hdl.handle.net/10197/12742
Publisher's statement	This is the author's version of a work that was accepted for publication in CIRP Journal of Manufacturing Science and Technology. Changes resulting from the publishing process, such as peer review, editing, corrections, structural formatting, and other quality control mechanisms may not be reflected in this document. Changes may have been made to this work since it was submitted for publication. A definitive version was subsequently published in CIRP Journal of Manufacturing Science and Technology (21 (2018)) https://doi.org/10.1016/j.cirpj.2018.03.003
Publisher's version (DOI)	10.1016/j.cirpj.2018.03.003

Downloaded 2026-05-01 23:37:31

The UCD community has made this article openly available. Please share how this access benefits you. Your story matters! (@ucd_oa)



© Some rights reserved. For more information

Biologicalisation: Biological Transformation in Manufacturing

G. Byrne^{1,*}, D. Dimitrov², L. Monostori³, R. Teti⁴, F. van Houten⁵, R. Wertheim⁶

¹ School of Mechanical and Materials Engineering, University College Dublin, Belfield, Dublin 4, Ireland

² Department of Industrial Engineering, Stellenbosch University, Victoria Street, Stellenbosch 7600, South Africa

³ Institute for Computer Science and Control, Hungarian Academy of Sciences, Kende utca 13-17, 1111 Budapest, Hungary

⁴ Dept. of Chemical, Materials and Industrial Production Engineering, University of Naples Federico II, Piazzale Tecchio 80, Naples 80125, Italy

⁵ Department of Design, Production and Management, University of Twente, Drienerlolaan 5, 7522NB Enschede, The Netherlands

⁶ Faculty of Mechanical Engineering, Braude College, Karmiel and Lavon Industrial Park, 2011800, Israel

*Corresponding Author: G. Byrne; E Mail - gerald.byrne@ucd.ie

Abstract

A new emerging frontier in the evolution of the digitalisation and the 4th industrial revolution (Industry 4.0) is considered to be that of "Biologicalisation in Manufacturing". This has been defined by the authors to be "The use and integration of biological and bio-inspired principles, materials, functions, structures and resources for intelligent and sustainable manufacturing technologies and systems with the aim of achieving their full potential." In this White Paper, detailed consideration is given to the meaning and implications of "Biologicalisation" from the perspective of the design, function and operation of products, manufacturing processes, manufacturing systems, supply chains and organisations. The drivers and influencing factors are also reviewed in detail and in the context of significant developments in materials science and engineering. The paper attempts to test the hypothesis of this topic as a breaking new frontier and to provide a vision for the development of manufacturing science and technology from the perspective of incorporating inspiration from biological systems. Seven recommendations are delivered aimed at policy makers, at funding agencies, at the manufacturing research community and at those industries involved in the development of next generation manufacturing technology and systems. It is concluded that it is valid to argue that Biologicalisation in Manufacturing truly represents a new and breaking frontier of digitalisation and Industry 4.0 and that the market potential is very strong. It is evident that extensive research and development is required in order to maximise on the benefits of a biological transformation.

Keywords: Industrie 4.0, Manufacturing, Biologicalisation in Manufacturing, Biological Transformation, International Perspective, Cyber-Physical Systems, Industry 4.0, Digitalisation, Bio-inspired, Bio-intelligent, Bio-integrated

1 Introduction

In Germany in recent times a field entitled "Biologicalisation" involving the integration of processes, principles and resources of nature into technical systems has been gaining increasing focus. It is deemed to be of considerable significance in the mid to long-term scientific and technological developments and is considered to have the potential to transform manufacturing as we know it today and to open up new and extensive markets for industries involved in manufacturing technologies and systems development. The underlying hypothesis being tested/challenged in the work reported here is whether or not "Biologicalisation in Manufacturing" represents a breaking and highly transformational frontier of digitalisation and Industry 4.0.

The German Government High Level Committees/Working Groups include the Chancellor's Innovation Dialogue, the Federal Government High Level Strategy and the National Platforms. One of the last innovation dialogues on biotechnology started the discussion about this field entitled "Biologicalisation."

The three main pillars that have been identified are (Figure 1):

- 1) Manufacturing and Materials,
- 2) Health, Food and Agriculture as well as
- 3) Environmental Sustainability and Energy.

Biologicalisation has not yet been wholly defined for each of the 3 pillars referred to above. This development is not being viewed as an independent branch of science in its own right, but is expected to develop through progress, transformation and advances in various research and industrial areas (e.g. in Computer Science (CS), Information and Communication Technologies (ICT), Biotechnology, Manufacturing Science and Technology (MST), Biology, etc.).

It is anticipated by some that, although it is still at a very early stage, the field of "Biologicalisation" may represent the start of an entirely new revolution, which has the potential to impact the industrial and business environments significantly, indeed in a transformational manner. In a 2012 policy workshop organised by the European Science Foundation [ESF, 2012] in conjunction with other similar organisations (including the National Science Foundation of the USA) the theme "Nature Inspired Design and Engineering for a Sustainable Future" was addressed. In a summary report from this workshop it is noted that "The big challenges of the 21st century, such as global warming, access to freshwater, sustainable production of food and materials, and improving quality of life in ageing societies, require a new approach to science and engineering more closely coupled with nature. Biologically inspired designs offer technologically novel and sustainable solutions to society's problems that may not be provided as quickly or economically by traditional approaches. A deeper understanding of how biological systems work can bring new insights and approaches to energy generation, conversion, storage, transport, and efficiency. It can also inspire advances in healthcare, and introduce a new age of materials with novel properties such as self-repair."

This White Paper deals with “*Biologicalisation in Manufacturing*” and it is recognised that manufacturing in itself is a broad area with numerous specialisations. It is also important to note that there is evidence to show that the early stages of a biological transformation is taking place with some convergence occurring between biomimetics, biotechnology and the bioeconomy. While these areas are broader than the scope of this White Paper, it is important that the wider perspective beyond manufacturing be monitored and where appropriate be integrated.

In this paper, the scope of manufacturing is restricted to the areas of work of the International Academy for Production Engineering (CIRP), which has a strong orientation towards discrete parts design and manufacturing. Five of the scientific technical committees (STC’s) deal with the processes of Cutting (C), Electro- Physical and Chemical Processes (E), Forming (F), Abrasive Processes (G) and Machines/Machine Tools, while the other five STC’s encompass Life Cycle Engineering and Assembly (A), Design (Dn), Production Systems and Organisation (O), Precision Engineering and Metrology (P) and Surfaces (S).

In addition to the STCs, collaborative working groups (CWGs) with an average life of 3 years are formed to address particularly important topics of the day. The CWGs frequently conclude their work with the publication of a CIRP Keynote Paper on the topic.

After considerable deliberation, the authors of the White Paper defined the term “Biologicalisation in Manufacturing” as being:

“The use and integration of biological and bio-inspired principles, materials, functions, structures and resources for intelligent and sustainable manufacturing technologies and systems with the aim of achieving their full potential.”

The underlying objective of this White Paper is to review the topic of “Biologicalisation in Manufacturing” in light of recent and current developments in advanced manufacturing and to provide an independent, international perspective and a vision on potential future developments. The authors seek to provide insight into the potential for intelligent and sustainable advanced manufacturing technologies and systems in the context of the use and integration of biological and bio-inspired principles, functions and resources. The scope of the work presented relates to biological transformation in manufacturing, recognising that manufacturing is inextricably linked to each of the other fields in all the pillars as shown in **Figure 1**: Materials, Health, Food, Agriculture, Environmental, Sustainability and Energy.

2 Biologicalisation in Manufacturing – A New Emerging Frontier of Digitalisation and Industry 4.0

The underlying concept of “Biologicalisation in Manufacturing” is not new. What is new, however, is the acceleration of the realisation of the concept, which builds on the capabilities available today and into the future through digitalisation and Industry 4.0 developments. Although not called by this name, the principles of biologically inspired manufacturing systems have a long history. Our late colleague and CIRP Past-President Professor Kanji Ueda (Japan) published in the journal CIRP Annals – Manufacturing Technology in the 1990’s in this area, which he called “Biological Manufacturing Systems (BMS)”. At that stage he wrote that “Today’s manufacturing faces significant trends of cultural diversification, lifestyle individuality, activity globalisation and environmental consideration”. In his paper [Ueda et al., 1997] he reported that Biological Manufacturing Systems (BMS) was proposed as a next generation manufacturing system concept aiming at dealing with non-pre-deterministic changes in manufacturing environments based on biologically inspired ideas such as self-growth, self- organisation, adaption, and evolution. BMS cover the whole product life-cycle from planning to disposal. At that point in time, however, the digitalisation was at a very early stage of development and the technology of the 1990’s was inadequate to facilitate the realisation of many of the concepts of the day.

Concerning the work reported in this White Paper and in line with the definition developed for Biologicalisation in Manufacturing, the approach adopted has been to analyse the factors and drivers relating to and influencing the key elements of the manufacturing value chain from an overall manufacturing technology and systems perspective. This is summarised in **Figure 2**. For this purpose, the manufacturing field has been subdivided to include: Materials and Surfaces (Section 3.1); Design of Products and Manufacturing Systems (Section 3.2); Manufacturing Processes, Machine Tools, Robots and Assembly Operations (Section 3.3); Production Systems, Supply Chains and Organisations (Section 3.4).

2.1 Digitalisation and Industry 4.0 as a Platform for Biologicalisation in Manufacturing

Nowadays humans are capable of producing materials that do not have a direct natural origin and of building machines that – in some fields - have intelligence that exceeds the capacity of the human brain and beats the human sensory system on all aspects by orders of magnitude.

Technology allows us to travel fast and efficiently even without the need for human attention or interference. Outer space has been explored and will be exploited. The development of nanotechnology and ICT has enabled the downsizing and proliferation of wearable devices that enable worldwide networking of (sensor) information. Big data and data mining allow for real-time information analysis and pattern recognition. Within the paradigm of Industry 4.0, it has become possible to connect manufacturing systems directly to the Internet. Machine to machine communication (Internet of Things) enables intelligent behaviour and flexibility. Where economy of scale has been the paradigm of the past, flexibility and customisation of industrially produced goods is now the standard. Manufacturing on demand becomes technically and economically feasible, but requires a different view on business models, logistics and impact on the labour market, the educational system and also on politics.

There is still a lot of discussion about the revolutionary or evolutionary character of Industry 4.0. The proliferation of ICT is clearly an evolutionary development. Sensors and actuators, in combination with (big) data analysis, artificial intelligence, digital twins, large scale (real-time) simulation, data visualisation by virtual and augmented reality are all elements coming together in an integrated way of instructing, monitoring and controlling our manufacturing systems [Nee et al., 2012]. The additionality in the value chain in moving from Industry 3.0 to 4.0 has been primarily through the cyber-physical systems (CPS) developments. Cyber-physical systems are systems of collaborating computational entities, which are in intensive connection with the surrounding physical world and its ongoing processes, providing and using, at the same time, data-accessing and data-processing services available on the Internet [Monostori et al., 2016]. In other words, CPS can be generally characterised as “physical and engineered systems whose operations are monitored, controlled, coordinated, and integrated by a computing and communicating core. The interaction between the physical and the cyber elements is of key importance. We must understand their interaction”.

Cyber-physical production systems (CPPS), relying on the latest and foreseeable further developments of computer science (CS), information and communication technologies (ICT), and manufacturing science and technology (MST) are leading to the 4th industrial revolution. Driven by the Internet, the real and virtual worlds are growing closer and closer together to form the Internet of Things. Industrial production of the future will be characterised by the strong individualisation of products under the conditions of highly flexible (large series) production, the extensive integration of customers and business partners in business and value-added processes, and the linking of production and high-quality services leading to so-called hybrid products [Monostori et al., 2016]. Connecting these objects to each other and to the relevant information systems provides a completely new level of transparency in the production environment, ultimately resulting in the creation of a digital shadow of the manufacturing processes. Real data from the shop floor is captured by a multitude of sensors, processed into information and used to make decisions. Assistance systems or actuators in the CPS are then used to implement the chosen measures. The complexity of these systems is immense, which implicitly increases the risk of failure and misuse.

Some of the current and emerging scenarios in relation to digitalisation and Industry 4.0 are:

- The opening up of decentralisation of manufacturing,
- Fundamentally new design paradigms e.g. through the rapid developments in 3D printing of polymeric, metallic and increasingly biomaterials,
- New supply chain architectures and new methods of supply chain integration are also emerging,
- Cyber-security as related to manufacturing,
- Diminishing latency,
- Much higher levels of automation,
- New unprecedented levels of connectivity,
- Machine intelligence and
- Bio-integration and bio-intelligence.

In a recent report [acatech, 2017] from *acatech* [The German National Academy for Science and Engineering] entitled “Industrie 4.0 Maturity Index” it was noted that the term “Industrie 4.0” exists since 2011 and refers to the “massive connection between information and communication technology (ICT) and industrial production”. The report refers to the management of the digital transformation of companies. The study highlights the point that Industry 4.0 is not merely a matter of connecting machines and products via the Internet. It points out that the use of new technologies and the acquisition of knowledge through targeted information processing will inevitably lead to new types of work and ways of working. This will necessitate changes to the structures within companies and the relationships between companies. The ability to analyse the prevailing corporate culture and existing patterns of thinking will thus be critical to success. Accordingly, the key challenges for businesses include understanding what Industry 4.0 means to them and systematically developing a corresponding implementation strategy. This *acatech* study focuses on these aspects as well as on the requirements of Industry 4.0 in terms of information technology and resources.

Sitting right at the core of the development of next generation manufacturing systems is the availability of the right type of data at the required granularity, at the right time, in the right place and at the required level of security. Manufacturing organisations, systems and processes have extreme levels of embedded data and the extent, quality and granularity of this data are continually improving as the Internet of Things, the extent and capability of advanced sensors and the connectivity levels increase. Multiple stakeholders are involved in the data across a wide spectrum of original equipment manufacturers (OEMs), tiered suppliers right through to end-users. The implications here are far-reaching in terms of the potential significant improvement to manufacturing process efficiency and optimised energy utilisation and the achievement of sustainable solutions.

However, the research community and industries involved in manufacturing engineering research are deeply challenged to acquire and provide the data at the required level of detail and reliability for the digital shadow development and for the manufacturing operations, despite the decades of research undertaken into the basics of manufacturing processes. It is fair to suggest that the manufacturing process data extracted in the past did not have the aspect of connectivity in a CPS context in mind and as a result has limitations in an Industry 4.0 and digitalisation context.

For example, industrial machining processes are among the most complex manufacturing processes to model and simulate. In metal cutting, the complexities stem from the severe plastic deformation of the metal, and from the extreme tribological conditions present at the tool-workpiece interfaces [Melkote et al., 2017]. A major challenge in developing constitutive and friction models of high fidelity for machining processes is the difficulty in acquiring dynamic stress-strain data and friction data, respectively that accurately represent the real cutting process. Recent microstructure evolution dependent constitutive models for metal machining require microstructure

data (e.g. grain size evolution as a function of strain, strain rate, and temperature) that are not readily available for many work materials of practical interest [Melkote et al., 2017]. Hence the current day ability to accurately model and simulate even the traditional basic cutting processes such as turning, milling and drilling etc. depends on the availability of accurate mathematical models for (a) the constitutive response of the deforming material and (b) the friction at the tool and workpiece interfaces, i.e. the friction model. From this it can be seen that serious limitations exist in the ability to accurately model and simulate manufacturing processes due to this lack of comprehensive understanding of the constitutive models. Furthermore, the material behaviour in the highly complex environment of extreme thermal and dynamic activity with progressive wear leads to change (on an ongoing basis) in the underlying mechanisms of material removal.

A similar situation arises across a spectrum of the manufacturing processes specified in DIN 8580. Other standards are required for harmonious interconnection between manufacturing systems. With the physical, the digital and now the biological worlds coming together, the overall complexity of the manufacturing system rises to entirely new levels. With the vast increase in the number of associated variables, the ability to model and simulate becomes an ever-growing challenge.

The issue of complexity in manufacturing systems has been given detailed attention in CIRP. However, this has generally not been in the context of the superposition of the areas of digitalisation, Industry 4.0 and biologicalisation.

In designing and operating manufacturing systems, the goal is to reduce complexity so as to make the system robust and reliable, guarantee long-term stability and minimize the cost. In the complexity theory presented in Suh's CIRP Keynote Paper [Suh, 2005] complexity is defined as the measure of uncertainty in achieving the functional requirements of a system within their specified design range. In the future world of biologicalisation, the demands from a functional requirements perspective will grow. The introduction of the human interface into manufacturing systems brings with it another level of complexity which is given consideration in the CIRP Keynote Paper on Modelling of Manufacturing Complexity [El Maraghy et al., 2003], [El Maraghy et al., 2012]. A methodology to systematically determine the product and process complexity for any manufacturing environment was also introduced.

2.2 Biologicalisation in Manufacturing – A New Frontier ?

Since the early work of Ueda [Ueda, 1992] in the 1990s there have been several published contributions to the field of "Biologicalisation in Manufacturing" - although not classified under this name/term. The recent CIRP Collaborative Working Group entitled "Bioinspired Manufacturing Processes and Systems (STC E) (January 2015 to August 2016) addressed some key aspects of the issues surrounding "Biologicalisation in Manufacturing".

Based on the parallel developments in relation to digitalisation, Industry 4.0 and biologicalisation, a level of extrapolation may be undertaken to provide some visibility on an early stage roadmap for Biologicalisation in Manufacturing.

In a CIRP Keynote Paper by Malshe et al [Malshe et al., 2013] in 2013 entitled "Bio-inspired functional surfaces for advanced applications", a critical review of inspiring biological surfaces and their non-biological product analogies is presented, where manufacturing science and engineering have adopted advanced functional surface architectures. Over millions of years, biological subjects have been in continuous combat with extreme environmental conditions. The fittest have survived through continuous evolution, an ongoing process. In particular, biological surfaces, which are the active interfaces between subjects and the environment, are being evolved to a higher state of intelligent functionality. These surfaces became more efficient by using combinations of available materials, along with unique physical and chemical strategies. Noteworthy physical strategies include features such as texturing and structuring, and chemical strategies such as sensing and actuation. These strategies collectively enable functional surfaces to deliver extraordinary adhesion, hydrophobicity, multispectral response, energy scavenging, thermal regulation, anti-biofouling, and other advanced functions. Production industries have been intrigued with such biological surface strategies in order to learn about clever surface architectures and implement those architectures to impart advanced functionalities into manufactured consumer products.

An interesting concept is presented in [Malshe et al., 2013] entitled "Nature's Tool Box" having interacting parameters including texture/topography, scale, chemistry, sensory system, complimentary sub-surface, shapes at multiple scales and integration of parameters. Examples for bio-inspiration are provided in this work including: advanced adhesion for surfaces, super-hydrophobicity to surfaces, advanced structural colours, advanced anti-fouling, advanced hard/tough surfaces, energy harvesting and advanced sensory systems.

In a report to the CIRP Collaborative Working Group on Bio-inspired Manufacturing Processes and Systems, Klocke presented work taking place at the Fraunhofer Institute for Production Technology [IPT] in Aachen, Germany, and the Centre for Manufacturing Innovation [CMI], Boston, USA [Klocke, 2015]. A distinction is made here between ordered surfaces and chaotic surfaces. Consideration is given to the production of nano- and microscale structures using laser structuring, diamond milling and 3D lithography.

Neugebauer et al. [Neugebauer et al., 2009] reported in 2009 on a design method for machine tools having bionic inspired kinematics. Here it is shown that a significant contribution can be made towards machine structures incorporating redundancy principles to overcome limits in dynamic performance and rigidity, thereby allowing new engineering solutions for a complete machining process.

Current manufacturing technologies need development in order to achieve the technological capability of producing complex, biologically inspired textures and structures. Micro- and nanomanufacturing thus takes on central importance. Nanomanufacturing involves scaled-up, reliable, and cost-effective manufacturing of nanoscale materials, structures, devices, and systems. Its methods can be classified into top-down and bottom-up approaches (See section 4.3), including additive, subtractive, and replication/mass

conservation processes. These include a cluster of various techniques such as nanomachining, nanofabrication, and nanometrology to produce, measure and evaluate nanotechnology components [Fang et al., 2017].

Two different approaches can be adopted in relation to Biologicalisation in Manufacturing. The first is the top-down approach where the technical problem is defined and followed by a search for biological analogies and their technical interpretation. The other approach is a bottom-up one, which begins with an analysis of nature or a natural occurrence followed by abstraction of the biological principles and a search for a technical application. **Table 1**, adapted from [Reap et al., 2005], depicts a bottom-up approach with a description of biological characteristics and the relation to an engineering solution.

Some of the high-level aspects of the new biologicalisation frontier seen to be opening up as a next phase of the digitalisation and Industry 4.0 developments include:

- New developments in chemistry and new materials,
- New products using new biomaterials,
- Classical industrial processes being influenced with potential for entirely new bio-inspired industrial processes to develop,
- Potential for new bio-inspired manufacturing equipment, including robotics, machine tools and measuring equipment and
- New bio-inspired models for production organisation including manufacturing systems and supply chains.

A review of the literature for this project was undertaken by [Wegener, 2017]. Based on this and in considering a vision for the future of manufacturing, it was proposed that next generation bio-inspired production processes could have self-learning and self-optimisation capabilities utilizing real-time information at the production machine. Hybrid processes will be involved and there may be potential for the considerable reduction or even the elimination of progressive wear (e.g. of forming and cutting tools). New bio-inspired materials for the workpiece and tooling may emerge. The processes will be resource and material efficient and new surface coatings and treatments for biocompatibility and for enhanced wear resistance may emerge.

Future machines may have self-healing capabilities, be self-adapting and have the capability for self-calibration. As a result of the extensive research into machine learning it may be assumed that machines will have higher levels of intelligence. The application of new materials in machine tools (CFRP composites, ceramics, lightweight materials, reuse of materials) can be expected. Machine tools will have many sensors for the monitoring of different physical properties for information about the actual machine tool behaviour and condition. The control systems with deeper intelligence will be capable of realising both model and situation based control algorithms. With the inter-connectivity possibilities, the future production systems will have higher levels of integration between different machine tools, measuring devices, handling and assembly modules and will incorporate live exchange of data. Machines will have a greater degree of bio-intelligence due to the introduction of cognition with controls that are based on the working of the human brain. They will have interaction between different receivers and signals from different sensors. The level of autonomy of machines and equipment in manufacturing will increase [Wegener, 2017].

There will also be new methods and technologies for assessing the quality of the bio-inspired components and surfaces produced. There will be additional requirements for metrology systems. The metrologists will be challenged to assess the uncertainties arising in the systems.

Some of these trends were evident at the recent Conference of the International Academy for Production Engineering [CIRP BioM, 2017] in Chicago where Mirkin [Mirkin, 2017] spoke of complete new directions in chemistry and the advent of new materials with capabilities way beyond the present limitations. New techniques for cell manipulation as well as for tissue building through entirely new additive manufacturing technologies were also reported on.

The key drivers for change include sustainability in terms of resources, demands for clean energy, and the trend towards individualisation. The advancements outlined above in terms of big data being extracted from sensors and adaptronics, the continuously advancing computing capabilities and the deeper intelligence in the technical systems facilitated through smart data and high granularity digital shadows are all key elements in this development.

2.3 Education and Training

A new generation of scientists and engineers will be required in the era of "Biologicalisation in Manufacturing". The future manufacturing systems will incorporate deeper integration of numerous different sciences including: human, materials, manufacturing processes, data, mechanical engineering, electrical, computer and electronic engineering, measurement etc. As with the Industry 4.0 paradigm shift, the additional paradigm shift with biologicalisation will require significant cultural change and development for next generation industries. Universities will be challenged to produce graduates with the required skillsets to work effectively in this new operating environment. Crafts-persons and technicians with new, different and interdisciplinary abilities will be required. It will be necessary to assess the skillset requirements for the design, development and operation of the processes, machines, equipment and production organisation and systems and to put the appropriate programmes in place.

In the context of the current and anticipated future status of digitalisation and Industry 4.0, the research work undertaken by the authors has shown that "*Biologicalisation in Manufacturing*" is emerging as a new frontier.

Section 3 continues with a detailed consideration of the anticipated future trends associated with materials and surfaces; design of products and manufacturing systems; manufacturing processes, machine tools, robots and assembly operations; as well as production systems, supply chains and organisations.

3 Focus Areas of Biologicalisation in Manufacturing

In line with the definition developed for Biologicalisation in Manufacturing and the related scope of work as illustrated in **Figure 2**, the following sections deal with the four main areas of today's manufacturing value chain from a system perspective: materials and surfaces, design, processes and equipment as well as systems and organisations. An overall systematic and unified approach has been adopted in the work reported below. After a brief characterisation of the field, some biologically-inspired approaches and current solutions are given. The main focus falls, however, on outlining future scenarios of exciting possibilities, but also on the substantial challenges involved.

3.1 Materials and Surfaces

It is universally acknowledged that the progress of civilisation has always been tightly connected to the development and application of new materials with increasingly enhanced characteristics.

3.1.1 Specifics of the Field

From ancient times until today, a wide range of new materials have emerged. Their application requires in-depth knowledge of their structure and properties.

Ceramic materials, employed for structural, functional or ornamental applications, are the oldest companions of human technological development. Thanks to them, human activities as diverse as space travel, smartphone and computer use, body armour, artistic decoration, sterilisation barriers, heat protection, are made viable and effective.

For seven millennia, human civilisation has progressed thanks to the use of only 7 metals: tin, copper, zinc, lead, iron, gold and silver. The 85 metals known today from the periodic table can be used for the most diverse applications, allowing for the realisation of advanced new products in today's world (**Figure 3**).

Polymers can be natural such as shellac, amber, wool, silk and natural rubber and have been used for centuries. They can also be biological, like the spider's web and synthetic like bakelite, nylon, neoprene, synthetic rubber, silicone, and many more. They are everywhere and play an essential role in everyday life.

By combining two or more materials with different properties, lightweight, high-strength composite materials are obtained. Their behaviour is inspired by biological composites ever-present in nature such as bones and wood. Composites have been made for thousands of years: one early example is straw and mud combined to form bricks for construction. Modern composites have successfully substituted conventional materials in numerous advanced technological applications.

Living organisms have evolved well-adapted materials, surfaces and structures over geological time through natural selection. Nature has solved technical challenges such as self-healing abilities, environmental tolerance and resistance, hydrophobicity, self-assembly, and harnessing solar energy. Learning from nature has long been a source of inspiration for revolutionary human implementations such as the realisation of flying machines from the study of birds in flight and that of submarines from the observation of whales diving into deep waters. Furthermore, particularly remarkable applications can be realised using biology-inspired multifunctional materials (bio-inspiration for complex superstructures) that can provide outstanding capabilities and functions, as presented in **Figure 4**.

3.1.2 Biologically Inspired Approaches and Solutions for Materials and Surfaces

The main developments in biology-inspired material solutions can be chiefly related to the physical material properties or alternatively to the material surface characteristics. Moreover, two main approaches for new bio-inspiration based developments can be identified [**Gleich et al., 2002**]:

- A more traditional approach based on the relationship between biological structures and their functions. This approach has been proven to be successful when the function is more related to the biological structure characteristics and less to the biological material properties. Accordingly, by replacing the biological material with an artificial material, the fundamental aspects of the function of interest are not lost, as the function is derived from the structural characteristics and not from the material properties.
- A more recent approach is represented by inspirations at very small scale such as the nanometer scale. This type of bio-inspiration is more related to the material surface characteristics than to the material internal structure. **Figure 5** illustrates a number of such examples: lotus function applications imitating the nanostructure of the lotus leaf surface protrusions that provide for self-cleaning, shark skin applications of tiles and coatings that prevent bacteria, butterfly wings applications to generate iridescent colours, abalone shell that provides high impact resistance, spider web capable of water

collection and high mechanical strength, water strider legs endowed with super-hydrophobicity that allows the insect to walk on water, compound eyes of moths and mosquitoes with anti-reflection and anti-fogging properties

Bio-inspired material solutions

In some instances, biological systems can be directly used for manufacturing purposes. This is the case of biomorphic mineralisation which is a technique that produces materials with morphologies and structures resembling those of natural living organisms by using bio-structures as templates for mineralisation. Compared to other methods of material production, biomorphic mineralisation is facile, environmentally benign and economical [Fan et al., 2009].

In other instances, existing biological materials can provide very interesting solutions for biology-inspired new material developments such as high hardness, metal-free materials. This is the case of metal-free bird beaks that are hard and strong as well as of the mandibles of the larval jewel beetle being as hard as some stainless steels by sheathing chitin fibres in protein and cross-linking, as reported by [Cribb et al., 2010]. Moreover, the self-sharpening hard teeth of many animals have been imitated to make cutting tool materials with enhanced functions, as described by [Killian, 2011].

New ceramics have been developed to imitate the properties of the conch seashells, which, due to the nanolaminae and biopolymer layers of their unique hierarchical microstructures, exhibit a remarkable ferroelectric behaviour and account for a huge polarisation with extremely high pyroelectric coefficients, 2–3 orders of magnitude larger than those of conventional ferroelectric materials. The possibility of tailoring the giant polarisation for various applications is considered in [Yao et al., 2013].

Achieving strong underwater adhesion is a true challenge since current technology is unable to firmly bond surfaces underwater due to hydration layers and contaminants on the surfaces. However, marine mussels can attach easily and efficiently to surfaces underwater under harsh sea conditions. Mussel foot proteins, containing amino-acid residues adapted to adhesive purposes, attach the mussel filaments to rocks, boats or any surface in nature. Simplified polymeric materials, bio-imitated from those of the mussel foot, have been developed to overcome the challenge of wet adhesion [Ahn et al., 2015] with potential for employment in nanofabrication protocols.

The self-healing function offered by biological materials (e.g. animal and human tissues and bones) can be provided by advanced materials applications. Diverse artificial materials, like polymers and composites, with embedded self-healing capabilities have been produced, based on biological materials, for applications aimed at mending cracks, internal damage and service impairment.

Regarding the development of innovative fibre materials inspired by spider silks to imitate their remarkable multipurpose capture/dragline properties of water collection, mechanical strength, elasticity, stickiness, supercontraction and torsional shape memory, several manufacturing procedures have been proposed [Benyus, 1997]. Artificial dragline spider silk has been fabricated by spinning soluble recombinant dragline silk proteins (ADF-3; 60 kDa) produced in mammalian cells under modest shear and coagulation conditions, as reported by [Scheibel, 2004]. Single-walled carbon nanotubes (SWNTs)-PVA composite fibres have been fabricated by spinning methods, which are tougher than spider silk and any other natural or synthetic organic fibre developed previously, as shown by [Young et al., 2013]. Artificial fibres were realised that mimic the structural features of wet-rebuilt spider silk and exhibit directional water-collecting ability; these fibres possess periodic spindle-knots constituted of random nanofibrils separated by joints made of aligned nanofibrils, as pointed out by [Zheng et al., 2010]. A manufacturing procedure for the fabrication of artificial spider silks using β -sheet nanocrystals is described in [Syntia et al., 2016] and illustrated in Figure 6(i). Figure 6(ii) shows artificial spider silks endowed with the capability to collect water in a number of knots along the fibres and Figure 6(iii) illustrates artificial spider silk fibres with high mechanical strength employed to fabricate high strength cloth.

Bio-inspired surface solutions

Bio-inspired surface technologies are being researched to develop coating processes of nanoporous materials that can produce super-hydrophobic surfaces on polymeric, ceramic or metal substrates. To mimic the anisotropic wetting function of rice leaves, a rice-like aligned carbon nanotube film was prepared by controlling surface deposition on the catalyst: Figure 7 shows (a) the cross-sectional SEM image of micropearl arrays, (b) the photo of a water droplet on modified micropearl arrays with measured contact angles, (c) the SEM image of natural rice leaf, (d) the photos of a water droplet on the rice leaf along both directions and the contact angle measurement showing the anisotropic behaviour [Xia et al., 2012].

The compound-eyes of the moth have properties that provide both anti-reflective and anti-fogging functions due to their peculiarly textured surface made of a large number of micro/nano hexagonal lenses which focus light from each part of the insect's field of view.

The light refractive properties of the moth's eye have been exploited to reduce the reflectivity of solar panels, and bio-inspired silicon hollow-tip arrays have been manufactured to mimic the antifogging function in an artificial "compound-eye like" surface.

Colours in nature are created by pigmentation, structural colour (iridescence) or a combination of both. Iridescence results from the interaction of light with high precision and complex surface textures and architectures, and has many properties and functions that are not achievable using pigmentation. The morpho butterfly wings surface creates tinting effects by the reflection of incident light waves at specific wavelengths, generating vibrant colours due to multilayer interference, diffraction, thin film interference, and scattering properties [Ball, 2012].

The scales of the butterfly wings are made of microstructures such as ridges, cross-ribs, ridge-lamellae and microribs responsible for structural colouration by light interference. The photonic microstructure of butterfly wings can be replicated to yield similar properties by using metal oxides such as TiSO₄, ZrO₂ and Al₂O₃.

Research into surface tension bio-inspirations is being carried out for the development of technologies of hydrophobic or hydrophilic coatings and microactuators. Interesting surface treatments can be envisaged based on biology-inspired surface solutions whereby air and water repellent surfaces prevent entry of fluids. This is the case with biofilm colonies of bacillus subtilis that are highly water and gas repellent due to a combination of chemical composition and nano-scale topography, as shown by [Epstein et al., 2011].

Nanotechnology surfaces that mimic the properties of shark skin are intended to enable more efficient movement through water. Moreover, the analysis of the texture of the shark skin, which does not attract barnacles or other biofouling unlike ship hulls and other smooth surfaces, revealed that this skin also repels microbial activity. Thus, bio-inspired plastic sheets with nano-scale textured surfaces were developed to provide antibacterial properties that are not a result of harsh chemicals or antibiotics but are purely structural due to the unique shape and configuration of the micropatterned surface.

Geckos are renowned for their exceptional ability to adhere to and travel on any vertical and upside-down surface, although their toes are not sticky in the same way that chemical adhesives are. Instead, they can detach from the surface rapidly and, moreover, gecko's feet stay clean despite surrounding contaminants (sand, dust, etc.) with just repeated use. The discovery about gecko's feet led to the idea that these structures and mechanisms might be exploited for new concepts of adhesives. The underside of a gecko toe typically bears a series of ridges, which are covered with uniform ranks of setae, and each seta further divides into hundreds of split ends and flat tips called spatulas [Autumn et al., 2000]. The adhesion between a gecko's foot and surfaces is the result of the Van der Waals forces between each seta and the surface molecules. This kind of intermolecular force is greatly dominated by the number of contacts and, as each gecko's foot has more than 1.5 million setae, this is the reason why geckos' feet can generate extraordinary adhesion forces on different kinds of surfaces. Thanks to the development of nanotechnology, it has become viable to create adhesives inspired by geckos' setae using nanostructures, although synthetic setae are still at a very early stage. Artificial materials like polymers were initially used for bio-imitation as they are flexible and easily fabricated. More recently, carbon nanotubes have been preferred as they have much larger length-to-diameter ratio than polymers and exhibit extraordinary strength and flexibility.

A number of MEMS fabrication techniques have been applied for the manufacturing of synthetic setae, including photolithography, electron beam lithography, plasma etching, deep reactive ion etching, chemical vapour deposition (CVD), and micro-moulding. There have been a wide range of applications of synthetic setae, also known as "gecko tape," ranging from nanotechnology and military uses to health care and sport.

Lotus leaves remain quite clean, though living in typically muddy habitats, without using cleansing agents or consuming energy. The leaf surface is made of soluble lipids embedded in a polyester matrix, displaying an extreme degree of water repellence (superhydrophobicity). This is due to the micro-texture of the leaf surface made of a large number of small surface protrusions, resulting in a roughened microscale surface, that causes the water droplets to collect and dispose of pollutants (dirt, dust, etc.) while they roll off the leaf by gravity. **Figure 8** shows (a) a photo of a lotus leaf, (b) enlarged image of the lotus leaf surface with water droplets, (c) t-shirt made of bio-inspired hydrophobic cloth. Surface finishes inspired by the self-cleaning mechanism of the lotus leaf have been applied to paints, glass, textiles, etc., reducing the need for chemical detergents and expensive labour [Solga et al., 2007].

In **Table 2**, different kinds of materials and methods/processes utilized to manufacture biology-inspired superstructures are summarised.

3.1.3 Future Scenarios and Challenges

Extensive analysis of bio-inspired technology and product innovation has shown that new material solutions development is the largest area of bio-inspired R&D, comprising smart materials, surface texturing, material superstructures, and materials with targeted applications. The number of the world's biological organisms is reckoned to be between 10 million and 100 million. Only a small number of them have been identified and an even lesser number have been fully studied. It is therefore obvious that the potential knowledge to be gained from biology is enormous. Moreover, biological solutions are public domain: i.e. any bio-inspired innovation initiative can freely make reference to biological "patents" and "copy" them without legal risks.

Bio-inspiration in manufacturing is, by definition, based on the analogical transfer of knowledge from biology, as source domain, to technology, as target domain [Mak et al., 2004]. The analogy may be superficial and based on transfer of high-level principles, or deepened and based on the transfer of precise structures or processes. The approach of superficial transfer is more connected to understanding and applying the natural idea or concept (bio-inspiration) whereas the approach of deepened transfer is more related to straightforward imitation (bio-mimicry).

The promise of bio-inspired material solution is massive. Millions of solutions are there to be taken into consideration by researchers. Biological material solutions have gone through the severe tests of natural evolution, have no limitations due to patents, can be very surprising, and can promote sustainable innovation. Even if the properties of biological materials are not always optimal, they represent a high-quality source of knowledge for break-through innovation.

Sustainability is a point of strength when developing innovations that make direct use of biological material solutions as they are intrinsically sustainable [Helfman Cohen et al., 2014]. In fact, biological systems made of biological materials do not create waste or irreversible damage to the ecosystem. On the contrary, they enrich and sustain the ecosystem where they operate. Moreover, biological

structures provide an extensive range of properties with minimal use and flow of materials and energy, and generate fully recyclable (natural) products. Finally, biological material structures are “manufactured” to operate within life and therefore avoid high temperature, high pressures or highly polluting materials [Benyus, 1997]. Following this last observation, if biologicalisation of manufacturing takes the lead in future industry, it could be envisaged that we may have a world with minimal or even no use of metal materials.

Biological data growth is huge and basic mechanisms have been discovered. Innovation based on bio-inspiration provides the opportunity to make this biological data applicable and productive in industry. If bio-inspiration is seen as an innovation engine, the biological data is its fuel that activates this engine toward innovations. However, there are a number of obstacles [Helfman Cohen et al., 2016] to the success of the bio-inspired innovation:

a) Scalability—Going from the micro scale to the macro scale can generate constraints. There are biological functions that work at the micro or nano scale but fail on the macro scale, e.g. the gecko adhesive function; artificial imitations of the gecko’s adhesive function have failed to show adhesive performance at macro scales [Bartlett et al., 2012].

b) Material constraints—There are cases where no artificial substitute is available for the biological material. This is particularly true when the function is more related to the material properties and less to the structure, e.g. spider silks. Although the molecular structure is known, artificial materials that can imitate the structure and maintain the unique properties are not yet developed [Syntia et al., 2016].

c) Manufacturing constraints—Manufacturing issues are among the major limitations on delivering bio-inspired innovations. E.g. the artificial lotus leaf products fall far short in terms of biological performance [Gleich et al., 2002].

Biological studies can describe a biological solution and an application for an analogical industrial problem can be identified thereafter. Most bio-inspired innovations came from the observation of particular biological functions that generated true amazement. The lotus leaf effect was discovered after observing a surprisingly clean lotus leaf in a very dirty environment [Solga et al., 2007]. The observation that penguins remain ice-free though they live in a very low temperature environment led to bio-inspired research to prevent ice formation on airplane wings [Helfman Cohen et al., 2014].

The fast process of building a new crayfish skeleton in a freshwater environment aroused the curiosity of a crayfish farmer whose research brought about the discovery of an amorphous calcium carbonate, which is the basis of a new bio-inspired calcium supplement.

Thus, bio-inspired innovations appear at the moment to be mostly intuitive. It is clear, however, that if transfer of knowledge between the biology domain and the technology domain is to be pursued, the search for biological materials with properties and functions of notable interest for new industrial applications should be systematised for an effective transfer of those properties and functions to technology.

The intuitive character of the present bio-inspiration for new material developments does not provide an answer for the main challenge of the transfer from the two diverse domains: bridging the gap between biology and technology. The intuitive approaches mainly answer the question of what can be done and not how to do it [Helfman Cohen et al., 2014]. The following queries should find answers and solutions on a systematic basis:

- How to find suitable biological materials for inspiration or imitation?
- How and what to transfer to the technological domain of application?

Attempts to answer these main questions can be identified in the literature and, accordingly, they fall under two high-level categories [Shu et al., 2011]: (a) searching/retrieval methods - methods to support search and retrieval of biological material solutions; (b) transfer methods - guidelines to assist manufacturers during the transfer process.

3.2 Design of Products and Manufacturing Systems

The design of manufacturing systems is closely coupled to the design of products to be manufactured. In mass production, the design of the manufacturing system can be fully optimised for a specific product, but in small batch or customised production the manufacturing system has to be very flexible. This increases the complexity of layout, planning and control. Digitalisation provides the computing power and intelligent software to handle the increased complexity of products and manufacturing systems.

3.2.1 Nature and Technology

The first attempts of human beings to use natural objects to improve their chances of survival quickly resulted in the need to modify them to increase their effectiveness and/or efficiency. Stones, tree trunks, branches, leaves and animal hides served as weapons for hunting and self-defence or as shelter, protection against the weather and means of transportation. The origin of manufacturing (made by hand: as opposed to created by nature) lies in the need to modify these natural objects.

As a consequence, the need for some form of product requirement specification and conceptualisation emerged. As long as design/manufacturing was a solitary act, this process was simple and implicit and the requirements could easily be adapted to the

possibilities to realise them. The main problem with the creation of new artefacts is that, in most cases the manufacturing process requires different material behaviour than the finished product (soft/hard, flexible/stiff, etc.). As design and manufacturing became a more collaborative effort, the need for communication about ideas, problems and possible solutions became more prominent and the process became much more complicated.

Producing goods for a community required larger scale setup and procedural skills to get uniform and reproducible results. Materials like clay and metals were discovered and used to make more effective and longer lasting products. Human muscle power was replaced by animal- or water-power and subsequently steam engines were introduced to drive looms in textile factories and to propel ships and trains (the first industrial revolution). Mass production with flow lines and division of labour made manufacturing systems more efficient and products more affordable for the emerging middle class (the second industrial revolution). The introduction of computer controlled machines made factories much more flexible, enabling them to produce customised products (the third industrial revolution).

The more design and manufacturing moved away from using primary natural resources and principles, the more effective and efficient solutions for human needs were implemented, but in the meantime unintended side effects emerged that turned out to be harmful for individuals, society and nature. The continuous evolution of technology makes it possible to create solutions for nearly every problem and has facilitated the massive growth of the world population, but at the same time it has depleted scarce natural resources and polluted the environment.

3.2.2 Specifics of the Field

Sometimes customers are able to envisage their future needs and to express their wishes and requirements explicitly, but most products are pushed to the markets by the companies producing them. In both cases there is room for propositions, interpretation or negotiation. Price, quality and delivery time may be variables that play a role in decision making. Sometimes the lowest price or delivery time is not a direct translation of (perceived) value like in jewellery, high performance cars, yachts, etc., but in most cases companies try to offer the best mix of the three aforementioned variables to underbid the competition. The product as a service is becoming a more and more accepted paradigm. As a consequence, the balance in the total cost of ownership is changing and so are the responsibilities of the vendor over the total product life cycle. Also, the products have become more complex than before. They often consist of a mix of tightly integrated mechanical, electrical, chemical, electronic, and software components. Their design requires an interdisciplinary approach, in which a lot of deep domain expertise has to be combined with teamwork and broad fields of interest, not only in the technical sense. The products of the future determine what the manufacturing systems of the future will look like.

The obvious need for an interdisciplinary approach has consequences for the way systems (products and manufacturing systems) have to be designed. This requires a different approach to the way designers are educated, on all levels. The subject/domain oriented way of working causes more and more problems for (large) companies that manufacture complex products. The classical departmental factory layout and separated design departments for mechanical, electrical and software engineering cannot deal with the increased complexity and interactions. Because of individualisation of the product offering and the smaller lot sizes, modular product design and reconfigurable manufacturing systems are required. This drives industry to simultaneous development of products and production systems with comparable levels of complexity. Existing paradigms for product and manufacturing systems design fall short and this drives us back to looking at what nature has to offer us in terms of materials, construction principles, organisational models, cognition, navigation etc.

3.2.3 Biologicalisation in Design

The term Biologicalisation has the connotation of a transformation process from the current state to a new one. It indicates that it needs to be reconsidered about how to benefit more from examples found in nature to resolve issues encountered in the highly complex systems that are to be designed and produced. Although those products and systems mainly contain artefactual elements and are mainly made of materials not used by nature, there are many things to be learnt from studying and retrieving principles that can be found in natural objects and systems.

Many design theories are based upon decomposition, finding partial solution principles and combining them to form an overall solution. Striving for identification of independent functional requirements that can be fulfilled by sharply defined design parameters, making a high level of decoupling possible, may seem attractive [Suh et al., 1998], [Suh, 2005]. The real problem, however, is in the combination of sub-solutions into an attractive looking and well-functioning product that will behave in a proper way during its total life cycle [Lutters et al., 2014].

Biologicalisation may be considered to be the crossing of a new frontier in the process of implementing Industry 4.0. It is about the use of principles borrowed from nature to overcome the interaction difficulties in complex technical systems that cannot easily be solved by decomposition.

Nature offers beautiful examples of highly coupled solutions for complex movements, distribution of forces and power, redundancy and graceful degradation, self-healing and regeneration [Shu et al., 2011]. Digitalisation of the manufacturing chain makes it possible to handle higher levels of complexity and enables the implementation of highly complex principles inspired by nature in artificial systems. However, it should be realised that biologicalisation is not a panacea for all difficulties encountered in the design, realisation and operation of those systems. Sometimes the operational requirements are quite different. Some scale rules or material properties from nature do not match the requirements of technical systems. Natural systems might have completely different life cycles or operating envelopes than artificial ones (flies versus micro-drones or birds versus airplanes). However, in nature there is an abundance of

principles to learn from, in particular about self-organisation, reconfiguration, cooperation and coordination as well as about adaptation, shape optimisation, graded materials, etc.

Many important contributions in the field of bio-inspired design, biomimetics, production of biomaterials, implants and prosthetics, tissue engineering (**Figure 9**), industrial production of natural drugs and vaccines, etc. have been published, amongst others, in CIRP keynote papers [Shu et al., 2011], [Bartolo et al., 2011], [Mitsuishi et al., 2013].

These are starting points for the renewed exploration of nature to gain inspiration for the improvement of the behaviour of technical systems while reducing their ecological footprint or even to help recovering from earlier industrialisation mistakes. The insights gained about the possibly massive consequences of the intensive use of fossil fuels during the past one hundred years now urges the industry and society to make radical changes in human behaviour. Technology makes it possible to implement these radical changes. Energy will be harvested from sunlight, water and wind. Electrification and automation of road traffic will dramatically change the automotive industry. Unmanned cargo aircraft and personal air transportation vehicles will appear. Legislation and liability has to be redefined. Decentralised power generation and distribution systems have to be implemented. Investments in traditional equipment have to be amortised at a much higher pace than expected. Alone in the field of transportation, many revolutionary changes will occur, that need new materials, propulsion-, control- and safety concepts. Also in these domains, one can learn a lot from nature: birds can presently manoeuvre better than drones (**Figure 10**).

Future products will be different. This also requires different manufacturing paradigms and factory concepts.

3.2.4 Structures, Surfaces and Materials

The use of metals as construction material will increasingly be challenged by alternative solutions. Until now, the handling of textile-like fibre reinforced composite materials has been problematic due to the relatively low demand, difficult automation of fabrication and management. Consequently high cost has hampered the use of these materials in consumer products, except for the (top) sports domain, but the massive improvement in computing power has enabled model and simulation based prediction and control of lay-up processes. The proliferation from aerospace to the automotive domain will give a tremendous boost in the use of composite materials, and thermoplastic matrix composites in particular. Design principles for complex shapes to be realised with these materials can be borrowed from the invertebrate skeletons of arthropods.

Additive manufacturing (AM) processes removed a lot of the traditional shape and structure constraints that were induced by traditional processes like machining, casting and mould and die manufacturing (**Figure 11**). The use of multi-material and graded material deposition techniques will allow tailored material properties that could not be realised before [Thompson et al., 2016]. Of course, additive manufacturing techniques have their own constraints, nevertheless, the designer's mind should be converted from "Design for Manufacturing" into "Manufacturing for Design."

With most of the geometric constraints removed, all kinds of nature optimised shapes can be used in combination with "designed" materials. A new generation of machine tools that combine additive and subtractive manufacturing is under development. Wire-Arc and powder deposition based additive manufacturing techniques enable the building of large structures like bridges. 3D concrete deposition is used to construct buildings. The virtually unlimited shape freedom of additive manufacturing techniques has inspired famous architects to create buildings that have organic shapes and look as if they were 3D printed. Also, the design of luxurious yachts and even airplanes have been inspired by these bio-3D print looks (**Figure 12**).

Additive manufacturing has the potential to supersede many traditional manufacturing paradigms, because it makes it attractive to produce parts with a much higher degree of complexity and integration and hence reduces the number of parts to build a product. Against the background of the need for individualisation, the flexibility offered by additive manufacturing matches well with the requirements. However, the production rate of the present generation of machines is rather low, though it is expected to increase dramatically in the near future. Designers should fully exploit the potential for integration of functional units and exchange their traditional paradigms about parts and assemblies in order to benefit from the new possibilities [Malshe et al., 2013]. New manufacturing technologies make it possible to generate surfaces inspired by nature that have superior properties in terms of wear and pollution resistance, optical and adhesion qualities, etc. Nature also offers a multitude of good examples of functional integration.

3.2.5 Manufacturing Systems Design

The original reason to build factories as we know them was the possibility to drive a large number of machines with one waterwheel and later one steam engine, because those power delivering devices were costly. This implied the need to bring workers together in a single factory building. With the introduction of electrical motors and control devices the factories became much more flexible in terms of layout and re-configurability. With the introduction of computer control and internet connectivity, enabling the manufacturing of individualised products within agile supply networks and on demand logistics, the need for concentrated factories for consumer products is diminishing.

Important trends on the product level are: products that the user carries tend to become smaller while products that carry the user tend to become lighter. These trends will change the way future factories will be designed (Urban production – the industry as a friendly neighbour).

The task of a manufacturing system is to convert product designs (sets of part and assembly specifications that have been fully documented) into working products. Within that paradigm: if something goes wrong, a discussion emerges about the possible cause, which might be allocated to an inconsistency or deficiency in the specifications or in a misinterpretation of correct specifications by the manufacturing system. As long as this resolves problems on the part or assembly level this is sufficient. However, because products are getting ever higher degrees of complexity, malfunctions cannot easily be traced back to individual parts or (sub-) assemblies (mechanical, electrical, electronic, software etc.). This requires that more intelligence has to be embedded in the manufacturing system itself in order to let it interpret functional product requirements rather than individual part or assembly requirements. Within the definition of Industry 4.0, machines can exchange information among them and also with the parts being manufactured. If the part carries intelligence, the routing as well as the processing requirements can be updated dynamically. If the so called digital twin, or the physical part itself can carry the requirement and status information (with updates) it becomes possible to generate alternative solutions to arrive at a functional product (zero defect manufacturing). However, the aggregated information should also be relayed back to the design office in order to track errors and the way they have been solved, in order to improve the design of future products as well as the design process itself. Data capturing should also be implemented in the product for gathering field data about the product during the use, maintenance and disposal phase [Maropoulos et al., 2010]. These requirements invoke huge data streams that have to be monitored, categorised and reduced to grasp the essence of the manufacturing system's behaviour and indicate how to improve it. Human operators should be able to interact with the manufacturing systems by cognitive user interfaces like augmented reality devices. The ever-increasing computational power boosts the digitalisation of the manufacturing industry and makes it possible to handle the immense complexity of (future) products and the manufacturing systems that produce them. Complexity implicitly increases the risk of failure and misuse. Both for implementation of self-organising capabilities of the system as well as the control of the effectiveness it might be helpful to look at examples from nature of how communities can contribute to the achievement of a common goal (ants, bees, etc.)

One of the other major problems is to justify investments for these highly complex and costly systems. Traditional asset management paradigms in terms of depreciation policy, utilisation rate, maintainability, re-configurability, etc., have to be reconsidered as well. Because everything will be connected and entangled, it can be very helpful to return to the base and find out how nature deals with highly complex systems. Finding good examples and using the underlying principles could stimulate designers to come up with more elegant solutions.

Product design and manufacturing systems design are heavily interrelated. If the product requires high flexibility then the manufacturing system should provide it. But there are many examples from the past (Flexible Manufacturing Systems, Computer Integrated Manufacturing) that have shown that an overkill in terms of flexibility causes excessively high cost compared to simpler solutions. It makes no sense to improve the efficiency of production systems that deliver unattractive products. As a consequence, it is of utmost importance to know what the future customer's needs and wishes are: The translation of future societal needs into desirable products is the key. In that sense, good product design is the driver behind sustainable manufacturing. Co-evolution of products, processes and production systems are of fundamental importance [Tolio et al., 2010], [Al Geddawy et al., 2010].

Nature gives hints in this direction like 'Survival of the Fittest' and the principle of redundancy to balance efficiency and effectiveness (most species will produce millions of seeds where only a few ones would be enough to replace it). In many cases there will be no reason to copy or mimic nature in manufacturing and proven technical solutions will do, but a renewed interest in studying natural principles in a broad sense to create balanced and effective manufacturing systems will be much more effective than in the past. The 4th industrial revolution allows to make use of the enormous increase in networked computing power and the abundance of sensor information (billions of interconnected devices).

This supplies product as well as manufacturing systems designers with very valuable information about the performance of their designs and the satisfaction of the customers. By using and reusing concepts borrowed from nature, a remarkable improvement may be achieved in the deterministic and mono-disciplinary approaches that have proven to be inadequate to deal with the level of complexity reached in the technical systems of today and certainly those of the future.

3.3 Manufacturing Processes, Machine Tools, Robots and Assembly Operations

With the ever-growing development of new biological and bio-inspired materials, structures, functions, and resources, manufacturing processes and machine tools have to rapidly adapt and evolve. A fundamental goal of biologicalisation in manufacturing is to allow for the production of socially beneficial, profitable products that restore or at least leave the environment undamaged. An impediment to the use of biologicalisation in manufacturing and engineering is the lack of knowledge of biological phenomena that are relevant to the problems at hand.

A manufacturing process, in the context of this section, is viewed as an individual operation. This includes, but is not necessarily limited to, geometry, surface roughness, microstructure, chemical composition, workpiece position, and packaging. The direct use of a biological entity and its products for a specific function that is not necessarily related to any single observable biological process within the entity, also falls under the scope of this section. A typical example is the use of microbes as lubricant during cutting operations [Meyer et al., 2017].

3.3.1 Specifics of the Field

The potential for biologicalisation in manufacturing processes, machine tools, robots, assembly systems, and sensors is vast and includes environmentally friendly and anti-pollution technologies. Intelligent operations, self-assembly and growth of products, material adoption and processing as well as direct use of biological entities and products also form part of this potential. Process and parameter optimisation, design, integration of biological functionality into structures, integration of biomimetic sensors into processes, and anatomy mimicry in robots are further examples. As natural solutions become nearly optimal over a long-term evolution process, manufacturing processes and products could also become near optimal through successful implementation of biomimetics and bionics. For the purpose of this study, no specific exclusions were made regarding manufacturing processes other than the requirement of being either biomimetic or a direct application of biology.

A machine tool is defined as a production system that enables a specific processing tool (e.g. cutter, grinding wheel, or laser) to alter the geometry of the workpiece in question. With the aim of implementing biomimetics based energy efficient machine tool design, Neugebauer et al. [Neugebauer et al., 2012] divided the optimisation of energy potential into the components level, the systems level, and the control level. Biologically-inspired solutions were found at each of these levels in literature, showing promising implementations in manufacturing industries.

Biomimicry in robots spans as far back as 1968, where Marvin Minsky developed a 12-joint robotic arm called the Tentacle Arm. It was inspired by an octopus and its tentacles. Since then robots have been developed through bio-inspiration and through copying the structures and animals in nature. All these developments are well documented in the literature. In this study, however, only these sources are taken into account, which are related to robots in production applications. This includes grabbing and joining, human-robot interaction, and human-robot work distribution. Robots and assembly systems generally go hand-in-hand with regards to biologicalisation. Most biomimetic assembly systems utilise robots as worker entities in order to perform a handling or assembly task with a bio-inspired gripper, according to some bio-inspired algorithm or process. Another assembly approach is that of a biological assembly process, which can be found in the form of cell division where cells divide to form more cells, which act as the building blocks of what will eventually become a living entity or end product.

Nature has developed and optimised an incredible variety of capabilities used by entities to extract information from the environment. By mimicking these, engineers are provided with new ideas to develop sensors and sensor technologies or improvements to current technologies, leading to potential sensor reduction [Bleckmann et al., 2004]. A sensor, in this context, is defined as an element, utilised to measure specific physical, chemical or geometric properties. Sensors can be grouped into the following ten categories: acoustic, biological, chemical, electric, optical, magnetic, mechanical, radiation, thermal, and other.

3.3.2 Biologically-Inspired Solutions Applicable to the Field

There are many different biomimetic solutions that have been implemented for improvement in manufacturing processes, machine tools, assembly systems, robots and sensors.

In machining, valuable time is lost when changing tools and moving the tool from one position to another. In order to decrease machining time and optimise the hole drilling process, many researchers look to nature for answers. Genetic algorithms were utilised by Abu Qudeiri et al. [Abu et al., 2007] to reduce the cutting tool path and by D'Addona et al. [D'Addona et al., 2013] to optimise the cutting parameters in turning processes. Tamjidy et al. [Tamjidy et al., 2015] made use of an evolutionary algorithm based on geographic distribution of biological organisms to reduce tool changeover time and tool travel. Particle swarm optimisation (PSO) and shuffled frog leaping algorithms were employed by Dalavi et al. [Dalavi et al., 2016] to optimise hole-making operations. There are many algorithms that were inspired through problems solved by nature that can be applied to various optimisation problems. Some of the biologically-inspired algorithms used for parameter optimisation in machine tools are [Dalavi et al., 2016]:

- Cuckoo Search (CS) Algorithm,
- Hybrid Cuckoo Search-Genetic Algorithm (CSGA),
- Genetic Algorithm (GA),
- Ant Colony Optimisation (ACO),
- Evolutionary Algorithm,
- Particle Swarm Optimisation (PSO),
- Firefly Algorithm (FA),
- Bumble Bees Mating Optimisation (BBMO) Algorithm,
- Shuffled Frog Leaping (SFL) Algorithm,
- Biogeography-Based Optimisation (BBO) Algorithm and
- Eco-geography-Based Optimisation (EBO) Algorithm.

Bio-machining is a machining process that utilises micro-organisms as a tool to remove metal from a workpiece. Bio-machining can be used as an alternative micromachining process, which is sustainable and environmentally advantageous. Other advantages of bio-machining include low energy consumption and low costs [Istiyanto et al., 2011]. Many species of bacteria are able to extract specific metals from their ores through their energy production cycle. Some species can consume copper and/or iron which could be highly beneficial to the manufacturing industry. Hocheng et al. [Hocheng et al., 2012] found that micro-organisms can be used to remove

material from copper, nickel and aluminium workpieces. It was further determined that bio-machining does not damage the workpiece layers as there are negligible thermal changes and forces applied to the workpiece. Two bacteria species can be utilised for bio-machining purposes:

- Acidithiobacillus thiooxidans [Chang et al., 2008] and
- Acidithiobacillus ferrooxidans [Hocheng et al., 2012].

Biomimetic tools hold certain advantages over conventional tools. In [Jiang, 2014], a self-sharpening cutting tool coating based on sea urchin and shark teeth architecture was developed. The serrated cutting edge of the tool is displayed in **Figure 13**.

The tool was shown to produce very good chip formation and a superior tool life when compared to benchmark conventional tooling. Other bio-inspired solutions for cutting tools are:

- Self-sharpening of sea urchin tooth [Jiang., 2014],
- Shark teeth shape and design [Jiang, 2014],
- Wood wasp drills [Gao et al., 2007],
- Bionic saw blade [Jia et al., 2013],
- Ball python scale design for cutting tool surface [Fatima et al., 2015],
- Bio-inspired tool coatings [Tillmann et al., 2015] and
- Bionic inspired vibration dampening for high speed milling cutter [Zhang et al., 2012].

Sensors are also key enabling technologies for Industry 4.0. In [Stroble et al., 2009], an overview of the wide range of biomimetic sensor technology and innovations available is provided. Sensors can be utilised throughout a manufacturing system in order to improve various aspects of the system and the feedback within that system. Biomimetic based sensors, which can be utilised in manufacturing may be classified into the following categories:

- Acoustic: Micro echolocation system,
- Chemical: Artificial chemical recognition sites,
- Electric: Fly based, non-camera motion detection system,
- Optical: Artificial ommatidia array,
- Mechanical: Carbon microcoil tactile sensors and
- Thermal: Thermal-Skin.

3.3.3 Future Scenarios and Challenges

Manufacturing processes

In line with technological advancement, a large number of variations of machine tools were developed aiming mainly at productivity improvement through faster drives, multi-axes configurations or operations integration. Another goal was the improvement of accuracy through better construction, advanced measuring devices and multiple sensors. With the application of biologicalisation to machine tool design and manufacturing, substantial benefits need to be revealed in order to trigger a shift in industry. The shift to bio-inspired machine tools design could happen incrementally by adopting various biological solutions over time. The first solution which industry could adopt is a shift from oil-based metalworking fluid (MWF) to a bio-based MWF. Most machine tools have flood lubricant mechanisms installed. Adoption of a bio-based lubricant will only require minor adjustments to the current machine system, relative to swapping out the entire machine. In [Meyer et al., 2017], a microbial based MWF was compared to a conventional water-based MWF during a milling operation. It was concluded that the microbial based MWF led to prolonged tool life and superior surface finish. The possible working mechanism during cutting can be observed in **Figure 14**. Mechanism 1 is where the cells prevent a metal-to-metal contact between the tribo-pair. Mechanism 2 shows a tribo-chemical working mechanism where the cell components form a friction reducing layer on the surfaces. Due to the fact that inactivated cells don't produce extracellular polymeric substances, a modification of fluid properties (Mechanism 3) can be neglected. Mechanism 4, the combination of all 3 mechanisms, is suggested to be the working mechanism for microbial-based metalworking fluid.

Biomimicry has been widely used to solve engineering optimisation problems. Nature based algorithms for parameter and process optimisation could be adopted by industry, as a change in programming or thinking is required. This could be implemented on current machines and systems without large investment costs. In [Montiel-Ross et al., 2012] Ant Control Optimisation (ACO) was utilised to optimise manufacturing time on a Computer Numerical Control (CNC) machine.

Biomimetic processing tools could also form part of the shift to biologicalisation in manufacturing. Like the MWF, most machine tools use some form of a tool in order to process material. Self-sharpening tools, which mimic creatures in nature, could decrease machining costs substantially if found to be more efficient and have a longer tool life than the conventional tools currently available. Adoption of biomimetic tooling will occur if the benefits could be associated with profits for the manufacturing industry. Benefits of this nature include extended tool life, better surface finish, and cost-effective tooling.

Machine tools

Application of biologicalisation in machine tool design could significantly change the concept of a machine tool. Based on inspiration from nature, Neugebauer et al. [Neugebauer et al., 2012] show three main directions of improving the efficiency of a machine tool: mobility, motion redundancy and lightweight design.

Observing the way of life of a woodpecker, the concept of a mobile machine tool was derived. In general, the machining of large workpieces is a challenging production technology. For this kind of application, it was suggested that the machine tool be mobile and the workpiece be stationary. Following these principles, in the future, decentralised machine tools could be an effective means to overcome these challenges. An illustration of this concept is depicted in **Figure 15**.

Movable machine tools would need to be lightweight in order to be energy efficient. In nature, many lightweight structures exist which have been optimised over time. Bone and plant structures present possible solutions for machine tool structural design. Neugebauer et al. [Neugebauer et al., 2012] investigated the X stand of a 5-axis machining centre and performed topology optimisation on the existing structure. The results of this optimisation can be seen in **Figure 16**.

A machine tool system that can mimic an ant colony or bee hive in terms of work distribution, individualised operations, and autonomy could also provide inspiration for the future of manufacturing processes and machine tools. With the increasing development of new sensors and control systems, autonomous machine tools should be in the spotlight for future advances. Just as an entity of a hive, colony or swarm is independent and autonomous in its activities, a machine tool could be independent and autonomous in its manufacturing ability. The machine tool or a swarm of machine tools could be called by the product like bees are drawn to pollen. The machine tools could then distribute and perform operations on the workpiece according to a biomimetic algorithm or task distribution hierarchy. Work suggesting feasibility of these concepts was performed by Parker et al. [Parker et al., 2003], where a swarm construction algorithm was developed to control robotic bulldozers in the creation of a work site.

With the vast amount of machine tools available in the world, adoption of a new machine tool technology could take considerable time. The driver for this adoption will be through the benefits associated with the change, usually in the form of higher profits. The lifecycle of a machine tool needs to be near its end before adoption of a new machine tool technology occurs. Also, training and education of the workforce should be a priority in order to drive companies to adopt a new technology.

Robots and assembly operations

In nature, there are various methods used to assemble required products. A weaver bird (Ploceidae) assembles its nest by collecting materials and weaving them together. Self-assembly of molecules can be observed in many instances in nature. Self-assembly can be observed in the cellular formation for growth of plants. Self-assembly occurs when an organised structure spontaneously forms from individual components through the specific, local interactions among the components. The current trend towards mass customisation of products presents new challenges in industry. However, this is a problem, which nature has been solving over thousands of years. There are many solutions, which can be derived by mimicking nature in this instance. With additive manufacturing, a product can be optimised and consolidated in a single print, rebutting the need for post assembly operations [Rodrigue et al., 2010]. This allows for a high level of customisation in parts.

A future assembly concept, which is being developed, utilises swarms of robots for group tasks and assembly. A decentralised model, where robots automatically build customer-specified products from modular parts could be the future of manufacturing assembly plants. The robots could also work on the same product according to a work distribution algorithm that uses the same method as that used by ants for allocating work. The robot assembly systems developed [Werfel et al., 2014] are highly robust and adaptable to the number of robots present for the assembly operation. The robots interact with each other as well as with the building blocks in order to assemble them into some form of structure communicated by the blocks. This could negate the need for assembly lines for certain assembly operations, as robots will just assemble and adapt according to availability and demand. A swarm of robots can be called by the parts that need to be assembled and the robots will assemble in an optimised manner that is dependent on the number of robots performing the assembly.

In distant future, self-assembled materials could become a reality. Materials that mimic the cellulose micro-fibrils in plants might negate the need for assembly operations and processes, for certain materials, in the future [Lurie-Luke, 2014]. Understanding the principles of cellular communication could be the driving force behind self-assembling materials. A better insight into cellulose polymerisation and self-assembly at the plasma membrane is required before substantial development of self-assembling materials takes place. In [Mendes et al., 2013] different applications for self-assembling peptides as nano-biomaterials are described.

Adoption in industry

With the development of self-assembled materials, a complete shift in design and manufacturing process thinking is necessary. Adoption in industry will rely on material properties, types and availability as well as the ability of engineers, designers, and biologists to adapt products and designs to effectively utilise the new materials and processes. Incorporation of self-assembly teaching into the engineering syllabus is required at a tertiary level in order to speed up the development and adoption of self-assembled systems and resources.

3.4 Production Systems, Supply Chains and Organisations

Growing complexity is one of the most significant characteristics of today's manufacturing, which is manifested not only in the products to be manufactured and the related processes, but also in the manufacturing systems and the company structures. The systems operate in a changing environment, which is rife with uncertainty. Difficulties arise from unexpected tasks and events, non-linearities, and a multitude of interactions while attempting to control various activities.

These complex systems are hardly manageable by human intuition alone. Large software systems take over many control tasks and support the decision makers at the different levels of the control hierarchy. This section shows how biologically inspired solutions, mainly Artificial Intelligence (AI) and Machine Learning (ML) approaches and new concepts of production planning and control can contribute to manage these complexities at least in a near to optimal way.

3.4.1 Specifics of the Field

Production systems and organisations differ from the other fields of Biologicalisation in Manufacturing mainly in respect to *higher complexity, larger geometrical and geographical spreading and to a higher level of human involvement*. Consequently, the main *expectations* towards biologicalisation in production systems and organisations are related to *complexity, optimisation, adaptiveness, robustness, resilience, evolution, self-organisation and cooperation* (all kinds of cooperation, i.e., machine-machine, human-machine, human-human).

It is worth mentioning that the cyber-physical era [Monostori et al., 2016], i.e. the unprecedented integration of the physical and the cyber spheres, in industry creates opportunities to realise biology inspired solutions in real practice, including production systems and organisations.

3.4.2 Biologically-Inspired Algorithms Relevant to the Field

At the beginning of the 1990s, a series of workshops was initiated within the International Academy of Production Engineering (CIRP), resulting in a comprehensive survey paper [Monostori et al., 1996]. Since that time, the following main biologically-inspired AI and ML approaches have come into focus, with some general industrial application examples [Floreano et al., 2008]:

- *evolutionary systems*: project scheduling, circuit design, robot control,
- *immune systems*: detection and recovery of faults,
- *behavioural systems*: surveillance, localisation, collision-free navigation,
- *neural systems*: from process modelling and monitoring to control tasks,
- *cellular systems*: sectoring, coding, tracking, cellular manufacturing,
- *developmental systems*: modelling, diagnosis, communication and
- *collective systems*: distributed search and cooperative multi-agent systems
 - *particle swarm optimisation*: dispatching, conflict resolution,
 - *social insect societies*: planning, job-shop scheduling, shop floor layout and
 - *swarm robotics*: transportation, distributed sensing, resource organisation.

The application possibilities of Artificial Neural Networks (ANNs) in manufacturing are versatile [Monostori et al., 1992], [Teti et al., 1997]. Learning algorithms including for instance deep learning offer the following potential advantages for manufacturing:

- increased production and service capacity and quality,
- improved maintenance, repair and overhaul (MRO) performance and
- provision of more relevant data and predictions for strategic planning.

Some remarks are worth making about the above bio-inspired AI approaches. In some cases, there are significant differences between the biological "solutions" and their artificial replicas. One may not only consider the kind of realisation, i.e. biology versus computer programs, or differences in the realisation speed, but also the fundamental differences. For example, remaining at the evolutionary systems, in nature there is no predefined goal, so these systems represent an open-ended adaptation process, whereas if one uses evolutionary approaches for optimisation purposes, appropriate fitness functions must be applied. Consequently, artificial evolution in its present form cannot possibly hope to result in the kind of diversity and creativity generated in natural systems [Floreano et al., 2008].

3.4.3 Some Biologically-Inspired Approaches to Production Systems, Supply Chains and Organisations

Production systems

The concept of *Biological Manufacturing Systems (BMS)* by K. Ueda aims to deal with dynamic changes in external and internal environments based on biologically-inspired ideas such as self-growth, self-organisation, adaptation and evolution [Ueda, 1992a], [Vaario et al., 1996]. In BMS two types of information are distinguished: genetic DNA-based information and information (knowledge) acquired through experience. The BMS concept belongs to those more and more frequently adopted approaches which use analogies taken from biology to develop more effective and robust products and systems. In fact, in Ueda's work multiple *cross-domain analogies* were applied, since

- when organising the structure of BMS, notions of *self-organisation, learning and evolution* were central, whereas

- in controlling the behaviour of BMS, the *physical* analogy of attraction/repulsion fields was taken to assign jobs to the specific manufacturing cells.

The benefits of the BMS concept were demonstrated in:

- *real-time scheduling*, where the products decided where to go for the next process without global control [Ueda et al., 2000],
- *line-less production*, where all the production entities (e.g., machines, inspection stations, etc.) were movable elements [Ueda et al., 2001] and
- *facility layout planning*, where the facility layout emerged as a result of the material flow in the virtual domain [Ueda et al., 2002].

The *holonic (or agent-based) manufacturing systems (HMSs)* by H. Van Brussel and P. Valckenaers consist of autonomous, intelligent, flexible, distributed, co-operative agents or holons [Valckenaers et al., 2005], [Valckenaers et al., 2015]. The PROSA reference architecture for HMSs identifies three types of basic holons: resource, product, and order holons [Van Brussel et al., 1998]. Staff holons are also foreseen to assist the basic holons in performing their work. PROSA augmented with *coordination and control mechanisms inspired by natural systems* (i.e. food foraging behaviour in ant colonies) guarantees that process plans are properly executed under changing conditions, while it continuously forecasts the workload of the manufacturing resources and lead times of the products (Figure 17). The design empowers the product instances to drive their own production; hence coordination can be completely decentralised. In contrast to many decentralised setups, the manufacturing execution system (MES) predicts future behaviour and proactively takes measures to prevent impending problems from happening. Hence, one of the most promising features of HMSs is that they represent a transition between fully hierarchical and heterarchical systems.

Autonomous processes in assembly systems rely also on agents. Agent-based approaches [Monostori et al., 2006] support the realisation of so-called plug-and-produce (plug-and-work) production systems where various elements are joined to a complete production system without manual configuration efforts [Scholz-Reiter et al., 2007].

The *intelligent, interlinked transport system* was developed in the Fraunhofer Institute for Material Flow and Logistics (IML). A *swarm intelligence* approach was used in the development of the cellular transport system consisting of intelligent, interlinked transport vehicles. They coordinate with each other independently without any central control. They are capable of moving on rails in the high-rise store and completely freely on the ground, i.e. without any guide markings, ensuring high flexibility. The vehicles communicate with each other and can coordinate their route planning. Collisions are avoided by an intelligent sensor concept as well as priority rules similar to those in road traffic.

Supply chains, production and transport networks

By using the newest developments of ICT, supply chains and production networks have acquired a complexity almost equivalent to that of biological systems. However, one of the major challenges that supply-chain management faces is the deployment of coordination strategies that lead to adaptive, flexible and coherent collective behaviour in supply chains. The *complex adaptive systems (CAS)* approach attempts to find common characteristics and/or formal distinctions among complex systems arising in diverse domains (like biology, social systems, ecology and technology). This might lead to a better understanding of how complexity occurs, whether it follows any general scientific laws of nature, and how it might be related to simplicity [Surana et al., 2005]. The CAS-approach was used by the authors to model and characterise supply chains and networks.

Supply chains, production and transport networks are critical ingredients of our modern society. Transport networks, for example, despite their importance have emerged without clear global design principles and were constrained by the priorities at their initiation [Tero et al., 2010]. The main motivation in further development of existing transport networks are high transport efficiency, i.e. at reasonable costs, and with less emphasis on making them tolerant to interruptions or failures, consequently, their robustness became a fundamental issue.

In biology, some organisms grow in the form of interconnected networks as part of their normal foraging strategy to discover and exploit new resources. In [Tero et al., 2010] the slime mould *Physarum polycephalum* was exploited to develop a biologically inspired model for adaptive, robust network development. The individual plasmodium initially explores within a relatively contiguous foraging margin to maximise the area searched. However, beyond the margin, it is resolved into a tubular network linking the discovered food sources through direct connections, additional intermediate junctions that reduce the overall length of the connecting network and the formation of occasional cross-links that improve overall transport efficiency and robustness. The study described showed that an appropriate biologically inspired algorithm can generate networks with comparable efficiency, fault tolerance, and costs to those of real-world infrastructure networks, using the example of the Tokyo railway network.

Organisations

Biological analogies can apply also for organisations [Schatten et al., 2011]. If an amoeba (a single cell organism) senses a potential victim it dynamically creates a pseudo-hand and absorbs the victim. Likewise, in an *amoeba organisation* teams are established if a new opportunity is recognised in the environment, which try to take advantage of it. Similar to the amoeba, organisational units change their shape by changing their internal relations, teams and members. Still the structure of the unit remains consistent. However, when a unit outgrows the limit of employees, a new unit is established, as the amoeba reproduces itself through division.

In the concept of the *fractal company* by H.-J. Warnecke [Warnecke, 1992] organisations are similar to complex systems that are characterised by fractals, i.e. objects that have a certain degree of statistical self-similarity on every observable resolution (the fern twig shows some characteristics of a fractal). In Warnecke's sense, a fractal is an autonomous organisational unit with its own objectives and

a function, which can be clearly described. Typical features of such an organisational unit are self-similarity, self-organisation and self-optimisation.

3.4.4 Future Scenarios and Challenges

In the past, the efficiency aspects of production were emphasized, sometimes even over-emphasized. Striving for cost efficiency, companies streamlined their operations, by outsourcing auxiliary activities, introducing just-in-time, just-in-sequence and lean management concepts. The enterprises usually work with low level safety stocks, and as a consequence, they may be vulnerable to turbulence occurring in their supply chains.

Nowadays, in addition to their efficient operation achieved by different *optimisation*, as well as the more frequent use of biologically inspired algorithms and techniques, the *robustness* of production structures, (i.e. their ability to cope with external and internal disruptions and disturbances), gains more and more importance. It became a fundamental requirement at every level of the production hierarchy from the process / machine level, through the system and enterprise levels, up to the level of supply chains and networks. In the literature, various definitions are given for the *robustness* of production structures; moreover, some related concepts (resilience, flexibility, changeability, agility, responsiveness, adaptability, etc.) are also in use. An appropriate formulation for supply chains is as follows: "In the general sense, a supply chain is robust if it is able to comply with the most important key performance indicators (KPI) set towards it, at an acceptable level (i.e. remaining in a predefined robustness zone) during and after unexpected event(s) / disruption(s), which caused disturbances in one or more production or logistics processes" [Monostori, 2016].

The concept of robustness can be found in different disciplines, e.g. in biology, economics, architecture, computer science, systems and control science, and – naturally – in mathematics (e.g. robust optimisation).

As to *biological robustness*: "robustness is a property that allows a system to maintain its functions against internal and external perturbations" [Kitano, 2004], [Kitano, 2007]. "To discuss robustness, one must identify system, function, and perturbations. It is important to realise that robustness is concerned with maintaining functions of a system rather than system states, which distinguishes robustness from stability" [Kitano, 2007]. Biological robustness – according to the kind of perturbation – can be classified as mutational, environmental, recombinational, behavioural, etc.

It is argued that robustness is a fundamental feature of evolvable complex systems, and evolution enhances the robustness of organisms, e.g. by increasing their complexity through successive addition of regulatory systems. Trade-offs between robustness, fragility, performance and resource demands can be observed in biological systems at different levels. Bacteria, for example, should be able to swim faster without negative feedback, but this would sacrifice their precision in following a chemical gradient: the use of negative feedback improves the bacteria's ability to follow the gradient, at the cost of reduced swim speed [Kitano, 2004].

In biology, the following "solutions" are distinguished to ensure the robustness of a system [Kitano, 2004]:

- *System control*: negative and positive *feedbacks*, for robust adaptation to perturbations, and for amplification of stimuli, respectively,
- *Alternative or fail-safe mechanisms*: for achieving *redundancy* by several identical or similar components or modules able to replace the one which fails, or by diversity or heterogeneity, whereby a specific function can be attained by other means available in a population of heterogeneous components,
- *Modularity*: for containing perturbations and damage *locally* to minimise the effects on the whole system and
- *Decoupling*: for isolating low level variations from high level functionalities. *Buffers* play a specific role here, e.g. Hsp90 (heat shock protein 90) decouples genetic variations from the phenotype, providing a genetic buffer against mutations.

The basic principles of biological robustness and the solutions to achieve it can be found in our technical domain, as well. A fundamental way to increase the robustness of manufacturing structures is to allocate reserves in physical and/or time domains (buffers, inventories or slack times). Another group of approaches relies on different (robust, reactive, predictive-reactive, proactive) scheduling techniques and distributed control.

It can be expected that the cyber-physical-biological solutions – through the quicker and more reliable recognition of the potential external and internal disruptions and disturbances, and through the minimisation or avoidance of their negative consequences – will significantly contribute to the better transparency and to the more robust functioning of production structures including supply chains. In the biologicalisation era, the complexity of production and logistics systems will increase in parallel with the opportunity for realising more robust systems. Consequently, the investigation of the relation between robustness, complexity and efficiency in the field of production structures will prospectively gain even higher importance in the future [Monostori, 2018].

The cyber-physical-biological approaches, i.e. the use of biomimetic solutions in production structures in the cyber-physical era, can open up novel and highly promising ways for making some viable compromises between these seemingly contradictory issues.

Figure 18 illustrates a framework of existing approaches – presently mostly in their research phase – to apply biologically-inspired solutions to production structures, indicating both directions, i.e., technology pull and biology push.

It is expected that – especially for more complex problems – the *combination* of several techniques will offer viable solutions. AI and ML are disrupting the fundamentals of many areas, including management and control of production systems, supply chains and

organisations. Research efforts reveal the implications and opportunities that come with these revolutionary technologies, as well as how they can be used as a tool to augment *human intelligence for performance advantage*.

4 Evaluation of the Potential and Impact

The evaluation of biological transformation undertaken here has shown that there is an ever-growing potential and impact on manufacturing, innovation and sustainability. A systematic bidirectional approach, driven by technology and industry (top-down) or by biology (bottom-up) can result in new manufacturing developments, innovations and new products. Such a systematic approach should be based on the various manufacturing topics and the different biological elements. The use of methodical models, such as the Gartner Hype Cycle, provides information on the potential and expectations of current manufacturing ideas or investigations and the current state of investigations and implementations. Reaching the full potential will only be possible by combining the various strategies with the collection of data, digitalisation and the development of new processes such as additive manufacturing (AM) technologies. Designing, manufacturing and using injection moulding dies are typical examples in this context.

4.1 The Growing Interest in the Transformation between Biology and Manufacturing

Interest in the relationships and transformations between biology or life science and engineering is an important and an ever-growing process. Mankind has been consistently looking to implement and exploit the high potential of biology, not only for food and health, but more and more also for consumer goods, agriculture, energy, materials, accessories and manufacturing. In the beginning, almost exclusively natural materials, simple biological elements and the five human senses were used or imitated due to limitations of knowledge, experience, equipment and materials.

Today, the question is how much and to what extent will it be possible to continue to learn from nature and to use its principles. What is the potential and impact of biology on our manufacturing industry and on new products? It is an ongoing process accelerated during the last decade due to increasing knowledge levels, enhanced scientific and systematic approaches and the 4th industrial revolution (Section 2).

The following sections evaluate the potential implementation and possible impact of biological transformation on technology and markets, and more specifically on manufacturing, including innovations and new products.

4.2 Potential Market and Challenges

There are various estimations and expectations for the market potential, possible activities, research and development challenges and innovation directions as discussed and presented in the previous sections and in many reports, market analyses and publications. Some of them are based on already implemented applications, others are in the R&D stage and some are only ideas, simulations and analytical considerations.

The economic impact of the various aspects of Biologicalisation in Manufacturing has not yet been fully investigated, although several reports indicate high expectations in financial terms.

A recent report "Tapping into Nature – The Future of Energy, Innovation and Business" by [Green, 2016] captures the enormous market potential of bio-inspired innovations and was summarized in the following citation: "The Fermanian Business & Economic Institute estimates that bio-inspired innovation could account for approximately US\$ 425 billion of USA GDP by 2030 (valued in 2013 dollars). Beyond 2030, the impact of bio-inspired innovation is expected to grow as knowledge and awareness of the field expand." The manufacturing sector is expected to be a significant part of it due to the large research gaps, digitalisation and further challenges.

In 2012 the European Commission established the BBI Consortium, the Public-Private Partnership for Bio-Based Industries. The current budget for Joint Undertaking between the European Commission and Bio-Based Industries is 3.7 billion Euros.

In many countries, activities and cooperations have been initiated between engineering and biomimicry organisations or biologists, academia and industry. In the USA, for example, Janine M. Benyus established the consulting companies Biomimicry Institute and Biomimicry Guild. She created the website Asknature.org to use as a platform for advancing biomimetic technologies [Benyus, 1997]. In Germany, twenty-eight research centres studying biomimetics have collaborated to establish the BOKON organisation sponsored by the Federal Ministry of Education and Research. Recently, 35 projects involving biomimetic products and technology have been conducted. In the UK, the Biomimetics Network for Industrial Sustainability (BIONIS), a network that connects businesses with universities, is being operated. In Japan, the Ministry of Education, Culture, Sports, Science and Technology is carrying out the Century Centre of Excellence, a graduate programme focusing on biomimetic monozukuri (biomimetic manufacturing) and novel uses of biotic resources in the field of agriculture. In many other countries, activities have been initiated between Biomimicry Organisations and biologists and engineers, academia and industry.

Bio-inspiration is viewed as a powerful innovative instrument that is transversal for diverse types of industries, comprising both traditional industrial sectors and high-tech industrial sectors. An extensive analysis of bio-imitated and bio-inspired technologies, including product innovations can be found in [Ferminian, 2013], [Helfman Cohen et al., 2016]. It reflects also in the impressive increase of related publications, patents and research centres. It concluded that development of new materials and new design ideas are the largest areas of bio-inspired R&D, comprising smart materials, surface texturing, material super-structures, and materials with targeted applications.

4.3 Strategies Used to Evaluate the Potential and Impact of Biologicalisation in Manufacturing

Moving from the “old” intuition approach, or random and scattered investigation of applying biology in industry, to the more systematic and strategic approach of Biologicalisation in Manufacturing, as reflected in this White Paper, provides completely new potential for improving manufacturing and introducing new innovation and new products. It is possible and applicable mainly due to increasingly more knowledge acquisition, digitalisation investigations, and new technologies. Some strategies to investigate the potential of Biologicalisation in Manufacturing, to exploit new opportunities and to present the current expectations are presented here.

4.3.1 The Bi-Directional Systematic Approach

The potential of using Biologicalisation in Manufacturing can be considered in the production range for innovating industrial products or for the complete manufacturing system, mainly by using inspiring or imitating biological and botanic elements, solutions, phenomena, materials, or living objects. The analysis of the biology-inspired potential for manufacturing and product innovations can be defined as an approach from the manufacturing level to biology, or as a “top-down” procedure, or problem-driven, or manufacturing-driven, or technology pull, all of them posing challenges to biology [Helfman Cohen et al., 2016]. A typical and known example for this approach is the extremely high noise of the bullet train in Japan when exiting from a tunnel due to changes of air pressure. The biological solution was found and implemented by imitating the shape of a kingfisher which dives from the air into water with little splashing.

The potential and impact of approaching manufacturing from the biological point of view is to analyse and evaluate biological materials, phenomena, properties, solutions or living objects and transfer, transform, imitate, be inspired by or use them for new applications, products, designs or manufacturing processes, as well as to improve product features or develop completely new products. This approach from biology to manufacturing and to product development can be defined as “bottom-up”, or biology-driven, or biology-inspired, or biology push, and can be considered as the “impact of biology on manufacturing”. A well-known example is the self-cleaning mechanism of the lotus leaves used today in self-cleaning of paint, glass and fabric described in Section 3.1.

Figure 19 presents a general block diagram showing a systematic bidirectional approach – “Manufacturing-Driven” (Blue) and “Biology-Driven” (Green) - to analyse and identify the potential and impact of Biologicalisation in Manufacturing. These two main directions are presented in five stages, either starting from the industrial/technical/manufacturing stage or from the biological/nature/scientific point of view, both aiming to improve manufacturing and products.

When starting from the manufacturing side, the first stage is to define the problem, including setting targets and goals for materials, surfaces, design, processes, control, system, organisation, functions, etc. In stage 2, deciding to check biological options requires searching for and identifying analogical solutions, relevant options, and similar concepts or to look for available solutions. Stage 3 starts with the selection of a relevant solution or a concept, including analysis and abstraction in order to explain and simplify it for the engineers. The ever-growing database, including biology, is an excellent tool to search for relevant algorithms and to retrieve updated information. In stage 5, following an iteration process (stage 4), the potential benefit to and impact on manufacturing is evaluated before transferring the “biological solution” to the relevant manufacturing topic(s). The manufacturing topics in **Figure 19**, are listed in accordance with section 3, while in many cases more than one topic should be considered at the same time.

The block diagram also includes the second method, the biology-driven or “bottom-up” approach from biology to manufacturing. Starting from a biological system with unique characteristics is followed by identification of these features, phenomena and functions in stage 1, and in the next stage by evaluation of possible implementations. The next 3 stages, starting from selection, abstraction and analysing, iteration and evaluation, followed by transferring the selected one to manufacturing are identical to the top down approach.

4.3.2 Analysing the Potential of Manufacturing Topics and the Impact of Biological Elements

Based on the procedure described in Section 4.3.1 and the various detailed information, ideas and conclusions in Section 3, a systematic and analytical approach is suggested here in order to investigate and evaluate the market potential, the range of improvements and new manufacturing developments, as well as industrial innovations and new products. Furthermore, such a system can help to select areas of similarities between biology and engineering. Generally, biological terms can be described analogously to engineering terms, as both natural and artificial systems depend on the same fundamental units.

Based on this assumption, a matrix was prepared, shown in **Figure 20**, combining the various manufacturing topics on the top with the similar biological elements (including botany) on the left side of the chart. It must be noted that this chart only represents an example for the purpose to explaining the methodology and does not show definite results.

The manufacturing steps range from material and surface, design and structure, machine tool, and robotics, processes and sensors, up to the complete production system and life cycle. The biological elements are divided into natural materials and compositions, surfaces, skin, cuticle, colour and visual shape, skeleton and bones, body and tree trunk, nervous system and natural sensors, brain and control system, muscles, life cycle and self-healing elements as well as social groups, herds and flocks or cooperation.

The blue circles refer to the potential of the manufacturing-driven approach (top-down), indicating areas of larger and/or smaller market and development potentials. The green circles indicate the biology-driven approach (bottom-up), while the strength of the colour indicates the estimated potential. For example, if a design team in the manufacturing line is looking for a biology-based solution

for a machine element, they should concentrate on the skeleton, bones and body, as well as on material and surfaces, while not neglecting the other elements. On the other hand, when looking for improved or even new production systems, life cycles or sustainability, social behaviour and life cycle in nature should be studied. Similarities between sensors, adaptronics, actuators or processes in manufacturing and biological elements such as nerves, natural sensors, muscles or self-healing elements can be used for industrial development and innovation. The evaluation given in the chart is based on and connected to the considerations outlined in this White Paper and broader background knowledge.

In general, the potential for new developments of materials and surfaces, described in Section 3.1, is based mainly (dark blue points) on features of natural materials and surfaces taking also into account body and skeleton. The biological results, based on ever growing know-how, systematic investigations using, for example, scanning electron microscopy (SEM) and data collection could stimulate their application in the manufacturing industry (see green points in **Figure 20**).

The range of design and structures of products and machine tools, including equipment and robotics, described in Sections 3.2 and 3.3 is probably the most interesting and promising area. (See blue points in **Figure 20**).

Biotechnology, biomimetics, bionics, bio-inspiration for design (BID) and mainly biomimicry approaches are considered as innovation engines not only for the high-tech range, but also for the traditional manufacturing industries. Using the evaluation procedure in **Figure 19**, as an example for optimising a design challenge, the first stage, after definition of the problem and setting the goals, will comprise the use of a biomimicry idea generator or a data base and select a biomimetic concept. The detailed, abstracted design is transferred to the design department or manufacturing team in order to investigate and produce a bio-inspired technical product or application.

Evaluation and developments of processes, equipment and sensors in manufacturing are presented in Section 3.3. Most of the biological elements in **Figure 20** can be considered with emphasis (dark blue and dark green) on the nervous system, natural sensors, brain and control, and muscles, while the latter can be compared to trigger inspiration or may even be imitated for future actuators.

The development of production systems, improvement of life cycle and self-healing, optimisation of supply chains and manufacturing organisations are very challenging topics, as discussed in Section 3.4. The much higher complexity and robustness of the manufacturing system and the analogue biological phenomena should be taken into account. The manufacturing requirements can be related to the biology domain mainly (see dark blue and dark green points in **Figure 20**) regarding the social behaviour of bands and flocks, insects and reptiles, group behaviour, and even the behaviour of plants and vines.

Swarm intelligence is a surprising biomimetic field, which describes developments in various fields inspired by insects, fish and birds. Today there are more and more developments based on swarm intelligence: image processing inspired by bird bands, termite-inspired temperature regulation, telephone communication protocols inspired by the infiltration of food in ports and more. Furthermore, efficient solutions are inspired by the ants' swarm intelligence for various processes, such as collecting goods in warehouses.

4.3.3 Using the Gartner Hype Cycle Model to Evaluate Future Manufacturing Technologies

The Gartner Hype Cycle methodology provides a graphical representation of expected development and implementation of new technologies as well as industrial applications over time. It is a sound source of insight to manage deployment within the context of a specific business goal.

A recent report by Wegener based on the Gartner Hype Cycle model [**Wegener, 2017**] discusses the question of when a new manufacturing technology, or a new product based on Biologicalisation in Manufacturing, could be commercially viable. The potential of many future technologies, presented in the report and in this paper, such as intelligent manufacturing systems (IMS), mixed reality (MR) for additional senses, brain computer interface (BCI), human robot interaction (HRI), configurable design, cognitive and bio-intelligent factories, self-organising systems and new learning approaches are presented in the Gartner type diagram (**Figure 21**) [**Wegener, 2017**].

The self-healing applications based on biological investigations are positioned in the diagram in the innovation trigger area, considered to have a potential for breakthrough with early- proof-of-concept followed by significant publicity within the next five to ten years (see Sections 3.1 and 3.3). Other topics such as cognition in machines, fleet learning, design and manufacture of IMS (intelligent manufacturing system) and BCI (brain computer interface) in manufacturing Section 3.4) are raising expectations based on investigations and publications of some success stories. Most of these technologies will need more than five years before they can be implemented in real manufacturing. The diagram also reflects the expectations that supervised learning could be implemented within two years, while unsupervised and unstructured data learning will need up to five and ten years respectively.

Some new technologies in manufacturing such as robot-human collaboration, multi-agent-systems, or advanced sensors are shown here in the Gartner diagram close to the plateau of productivity and are expected to be implemented within the next five years. The direct connection between the human brain and nerve signals to machinery (Cyborg experiments) as well as self-organizing systems, cognitive factory and intuitive HRI (human robot interaction) have relatively high expectations or potential, but require a longer time to be verified and implemented. Processes such as holonic manufacturing systems and multi-agent-systems are passing through a disillusionment period, mainly because experiments and applications failed to deliver.

Figure 22 presents the potential for materials and surfaces using the Gartner Hype Cycle (as recommended in Section 3.1). According to the expectations and potential for developments of materials and surfaces imitating biological phenomena, it can be expected that an increasing number of implementations will take place in the near future. For example, it is expected that high mechanical properties in metal-free materials can be achieved within five years, probably based on biological phenomena such as those characteristic for “spider silks” described in Sections 3.1 and 4.4. Technologies for realising products with properties such as anti-reflection and low friction, structural colouring, water collection, self-cleaning, or superhydrophobicity are based on biologicalisation and expected to be used in industry within the next five years.

Similar diagrams for applying biology-driven solutions in manufacturing can be presented for other topics as described in Section 3.

Manufacturing ideas, implementation potential, or new products positioned on the right upwardly directed curve can be considered to be in the stage where mainstream adoption starts to take off. The broad market applicability and relevance of the technology are clearly paying off. Supervised learning, mixed reality (MR) for additional senses, advanced optical sensors and E-skin in **Figure 21** and thermal insulation in **Figure 22**, located on the curve in this area are showing the great potential of implementing biologicalisation in the various manufacturing areas and product developments.

4.4 Examples for Potential of Manufacturing-Driven, and Impact of Biology-Driven Applications

Following the previous sections, this section presents some examples indicating the main directions, the potential and the impact in connection with the evaluation charts in **Figures 20** and **21**. On the one hand, industry and manufacturing use biology ever more as an inspiration or as a concept for improving manufacturing technologies as well as for the development of new products and new market innovations. On the other hand, systematic investigations and knowledge in the biological domain have a growing impact on manufacturing and products.

Design, optimisation and manufacturing of a moulding die based on biology and using additive manufacturing technologies

This example demonstrates the manufacturing-driven approach – “top-down” - for optimising the design and the production of a moulding die. The process started by using a search and an evaluation procedure of biological solutions combined with the option to use new production technologies.

The project investigated the manufacturing of a plastic injection moulding die with optimised coolant channels based on biomimicry using additive manufacturing [**Carson, 2015**]. The project, carried out by HARBEC INC., was aimed at developing conformal cooling channels in the die to increase the cooling surface area to provide even cooling of the mould and to save energy. The DMLS (direct metal laser sintering) or SLM (selective laser melting) technology was used to produce the complex die, including the cavity and the curved, twisted coolant channels with non-constant cross-sections. The main objective was to use biomimicry in the design and structure of the conformal cooled channels and the cavities as well as to optimise machining and performance. A number of biological and natural botanical structures, shown in **Figure 23**, were analysed and reviewed: (a) capillary action in plants, (b) convection cooling in termite mounds, (c) large thin animals as vascular systems and (d) in leaves acting as heat sinks, and vein structures in mammals.

The structure of the dicot leaves, with large straight veins that feed smaller veins, thus providing an optimised shape, was selected although the heat transfer of leaves relies on evaporation, while moulds rely on conductive heat transfer. The complex moulding die, based on the dicot leaves structure and developed and produced by additive manufacturing, has an improved, optimised and efficient cooling structure combining large and small channels.

The mould, which is made of aluminium and has the optimised cooling channels inspired by the dicot leaf structure, was produced by additive manufacturing. It comprises a large entrance channel with different and smaller branches. **Figure 24** shows the moulding die for the plastic components with its complex cooling channels, which are inspired by the cooling structure of the dicot leaves. This design provides optimal cooling of the die and the part, high energy efficiency, improved properties and optimised performance. Using the biologicalisation approach, combined with the AM process, results in reduced cycle time and energy consumption, better final product quality and faster mould production. The principles of biological transformation were successfully assessed and incorporated in the design, the structure, and in the production of the mould. This represents a very promising example for Biologicalisation in Manufacturing.

Material, structure and process optimisation in manufacturing new fibre products using the biology-driven approach

This example is based on a biology-driven approach (bottom-up) related to the material, structure, design and manufacturing of fibre materials for industrial products. The topic discussed in Section 3.1 is: “Production of new materials based on high strength spider silk fibres”. The new and unique products for the next generation were developed by Seevix [**Shen, 2017**] by using high-performance functional materials based on man-made spider silk fibres., The integration of these fibres with other materials resulted in new composite materials, enabling reinforcement of various matrices and expanding the potential applications of the fibres. The new functional components such as meshes, films and threads are used for products requiring toughness, strength and elasticity. Although the tensile strength of the biomaterial is comparable to steel, it exhibits a significantly greater elasticity and a higher toughness compared to synthetic fibres such as nylon or aramid. The strength is six times higher and the weight is 1/5 compared to high-tensile

steel of a similar diameter wire. The production of synthetic spider silk, which is identical or superior to natural fibres, can radically improve existing products and provide solutions for unmet demands.

These reinforcing fibres for creating new composite materials can be used in custom-made components for specific industries and products such as tyres for the automotive industry, body armour in the defence industry, improved polymers for 3D printing, sporting goods such as shoes, safety glass and frames, or premium surgical equipment.

Solving a problem regarding material, design, machine tool, process, and life cycle by using the bi-directional approach

The development of a new flexible steel pipe replacing an existing approach is an example representative for a manufacturing-driven systematic approach using the potential of biology to solve problems and improve products. The main problems of friction and wear combined with distortion of surface and structure are related to material, surface, design, structure, and life cycle of the machine tool element. The steel pipe, located at the exit from a machine tool, showed rapid wear due to abrasive material flow and needs to be repaired or replaced frequently. The manufacturing team was looking for a steel-reinforced pipe that is still as flexible as a rubber hose. Instead of looking for a solution in their field of expertise or only in the conventional industry, they decided to pursue a completely new approach and looked for a solution based on a biological example. They identified three structures that meet the requirements: caterpillars, fish and snakes. After a systematic investigation, they found that the best structure was the snakeskin since it includes a series of interlocking scales that enable movement and constant protection against erosion and wear at the same time. It was proven that the systematic investigation using biological inspiration provided a unique and previously unknown solution.

Birds' wings as a potential solution for wind turbines

The next high potential example of a biology-driven approach is the mechanical flapping of birds' wings providing the basis for developing innovative wind turbines utilising biomimetic principles. The production of energy is more efficient due to the combination of upward and downward movements. In the future the new principle could be used for manufacturing wind turbines of various sizes for different purposes in addition to producing more efficient industrial engines for various applications.

Biological solutions – potential for sensing and self-healing in manufacturing

Ideas and procedures of Biologicalisation can also be used for identifying, sensing, self-healing or self-correcting and reinforcement of irregularities and failures in products and processes as described in Section 3.3.2. In nature, the rhinoceros uses a horn to locate plants and minerals hidden in the soil and as a means of defence and attack. When carrying out these functions, the horn acts as a cantilever beam and is exposed to mechanical loads of torsion and compression, which can cause cracking and damage to the horn. Inspired by the Rhino Foundation, an innovative self-correcting concrete that contains resin-filled micro-capsules is being developed. When small cracks begin to develop in the concrete, the resin pellets open and fill the gap created by the crack.

5 Current and Future Standards

Missing or incomplete standards and regulations often hinder the introduction of new solutions. In this section, current standards and regulations related to biologicalisation are surveyed and some deficiencies together with the future requirements are highlighted.

5.1 Current Standards and Regulations

Current available standards are focused on the concept of biomimetics ('Bionik' in German) in which a function from nature is identified and adapted through an abstraction process to either aid in finding or directly yield a solution to a technical problem. The following identified standards are directly applicable to the central themes of this paper: materials and surfaces; design of products and manufacturing systems; manufacturing processes, machine tools, robots and assembly operations; production systems, supply chains and organisations.

VDI 6220: Biomimetics conception and strategy – Differences between biomimetic and conventional methods/products

ISO 18458:2015 – Biomimetics – Terminology, concepts and methodology

According to the given definition “Biomimetics combine the disciplines of biology and technology with the goal of solving technical problems through the abstraction, transfer, and application of knowledge gained from biological models” [VDI_6220, 2012]. Two closely related international standards, VDI 6220 and ISO 18458, present the concept and methodology for consulting the biotic sphere towards either biological discoveries that have technological potential (bottom-up approach or biology push) or for solution finding for a technical problem (top-down approach or technology pull) [VDI_6220, 2012], [ISO_18458, 2015]. The former is typically initiated within a biological discipline and the latter in an engineering field. This clearly implies that scientific fields overlap within biomimetic developments. These standards also suggest guidelines for communication by standardising the terminology to reduce potential ambiguity. It specifically concerns the concept of biomimetics, providing terminology, application guidelines of the biomimetic process, and examples of biomimetic developments. These standards further delineate biomimetics from parallel innovations by means of assessment questions. Biomimetics requires for the solution to be abstracted from a biological observation of a relevant function. Form and function are analysed and an interface is developed through which it can be further refined considering available technologies. Furthermore, education and the emerging importance of multidisciplinary training and research programs are emphasised.

VDI 6221 – Biomimetic surfaces

This standard describes the biomimetic process applied to the development of surfaces for enhancing functionality. It lists a variety of functions that are typically incorporated in technical applications and briefly discusses each of these with the aid of examples. Definitions for selected terms (bio-adhesion, biomimetic surface system, bio-tribology, chromatophores, evolution, boundary surface, lotus effect, surface, semipermeable membrane) are provided in reference to their use within the document. As a conclusion, the biomimetic process is revised with regard to the development of surfaces with enhanced functionality inspired by nature [VDI_6221, 2013].

VDI 6222 Biomimetic robots

Terminology for biomimetic robots is provided. Biomimetic robots are defined as “robots that possess an implementation of at least one dominant biological principle and are usually developed based on the biomimetic development process” [VDI_6222, 2013]. The topic of human-robot interaction is discussed and an emphasis is placed on compliance requirements of robots since humans lack strength and precision of movement. Therefore, lightweight design, adaptiveness, and intuitive operability are important criteria for biomimetic robots. Sensors are identified as important components but not discussed in depth. The following topics are identified as important for future developments: decentralised control functions, feed forward control, adaptive behaviour, and force guided control. Robot development incorporates algorithms based on laws of evolution and inspiration from nature, which appears to be a recurrent application throughout all standards for biomimetic developments. These algorithms are therefore also highlighted for their importance [VDI_6222, 2013].

VDI 6223 – Biomimetic materials, structures and components

ISO 18457:2016 – Biomimetics – Biomimetic materials, structures and components

The main areas of current biomimetic standards are highlighted. A summary is provided on the characteristics of biological materials. It juxtaposes the multifunctional and adaptive properties of biological materials to the much more limited multifunctional nature of technical materials. Furthermore, it points out the difficulties in applying standard technical material testing methods to biological materials, since the heterogeneity and structure/function relationships mean that samples cannot be “averaged out” but must be tested according to very specific conditions taking effects such as geometry, heterogeneity, and ambience into account [VDI_6223, 2013], [ISO_18457, 2016].

VDI 6224 Part 1 – Biomimetic optimisation - Application of evolutionary algorithms

A description of the evolutionary algorithm concept is provided. The standard then works through an application example based on the design of a thin optic focal lens. It then further presents examples in the form of continuous, discrete, combinatorial, and multi-objective optimisation problems. A narrative approach is used instead of specifically focusing on instructions, leaving the potential user room for creativity within interpretations and abstraction. For further instruction, it refers to various literature sources in which the theory of the algorithms is discussed in more detail [VDI_6224, 2012].

DIN ISO 18459 Biomimetics – Biomimetic structural optimisation

The standard provides terms and definitions. Central themes to this are computer aided design optimisation methods, with an emphasis on the importance of the finite element analysis method. Mainly it is based on the paradigm that structures in nature are highly dependent on applied force and adapt themselves to changes in loading conditions in order to allow for a more uniform stress distribution. Methods presented in the standard Computer Aided Optimisation (CAO), Soft Kill Option (SKO), Computer Aided Internal Optimisation (CAIO), Method of Tensile Triangles, are in development.

The intended application is for static load, or where dynamic loads are concerned, equivalent static loads. Examples are provided for each of the four above listed methods. The biomimetic origin of the optimisation methods is focused on more closely than implementation and programming details, although basic process algorithms are provided. The main shortcoming is inevitably that, due to ongoing refinement of existing methods and the development of new methods, the standard is quickly going out of date. However, since the main focus of this standard is the biomimetic nature, separate standards could be developed to guide the implementation of these methods with reference to specific software packages and programming languages [DIN_ISO_18459, 2016].

Although only a few standards directly applicable to biological transformation in manufacturing are discussed in more detail, **Table 3** above provides a list of current standards, including those not necessarily relevant to this paper. It is also possible that more standards exist with applications beyond the scope of manufacturing, however, the standards in the list represent the most prominent and readily available documents on the topic.

5.2 Deficiencies and Future Requirements

Deficiencies

Biological transformation should not be regarded as the ultimate solution and its dependency on concurrent technological developments, not necessarily inspired by nature, should be recognised. One should also recognise that, due to mutations and the

natural selection process, the surviving configuration is not necessarily the best, but simply better than the predecessor. Furthermore, evolution is a forward only process, and not an iterative design process where whole components can be readily redesigned based on new knowledge and discoveries. This implies that nature should be carefully evaluated for the efficiency of a particular relevant solution and not merely copied based on the premise that time has yielded an optimal solution.

As mentioned earlier, the main shortcoming is inevitably that, due to refined or newly developed methods, standards may go out of date relative quickly. However, since the main focus of the currently available standards is on biomimetics, separate standards should be developed to guide the implementation of these methods, e.g. with reference to specific software packages and programming languages [DIN_ISO_18459, 2016].

Another important issue relates to education. Current standards do in fact emphasise the role of biomimetics in education and the importance of establishing multidisciplinary research groups. Within these areas, a potential exists to cultivate a renewed respect for nature and therefore contribute towards a learning culture that is first of all based on environmentally conscious and sustainable functionality rather than pure monetary gain.

A further deficiency concerns policy or legislative standards from an international perspective. Considering products or services, it is possible that a single company would need to comply with the regulatory requirements of various national governments. It is therefore possible that global legislation and policies with respect to certain aspects could emerge. Given the notion of service provision rather than complete ownership by the consumer, it implies that suppliers of these services would operate globally. Should one of these be, for example, a self-driving transport solution, international standards for risk management, safety, and maintenance implies that national governments would not necessarily anymore have independent control over transport legislation. It would be rather responsible for implementation of policies and legislation devised by a global governance body.

Requirements

Of particular importance is that sustainability should have a prominent presence in the motivation for developing anything via the biomimetic process. It should even be defined as a requirement. For example, according to section 5.1, the standard [VDI_6223, 2013] states that developing a product through biomimetic methods may increase its market value, however, what use would there be if the aftermath of such a product is more devastating to the environment than its predecessor? Therefore, a risk exists in which “biomimetic” may very well be reduced to only a label that companies use in an attempt to gain a competitive advantage.

Considering the relatively fast pace at which new technological developments arise and improve in comparison to the time required for standards generation, the risk continually exists for the surfacing of ambiguous terminology and methodologies. It is therefore important that draft standards should be expedited in order to streamline the resultant scientific literature by, amongst other things, eliminating ambiguity. This is evident, for example, in several aspects of the additive manufacturing domain, specifically powder bed fusion (PBF), where the same exposure patterns are termed differently due to independent development. Of great importance is that the standards are not regarded, or even intended, as being “cast in stone”, which might limit the scope of creativity for researchers. They should be rather created with the intention to streamline improvements or developments by fixing terminology and thus reduce redundancies of concurrent developments.

Furthermore, due to the inevitable uncertainties and complexities of social and technological evolution patterns, the standards should remain open for adaptation and revision, not necessarily in a negating sense, but in a complementary sense while meticulously recording all revisions to allow ongoing research the opportunity of access to historical data in order to enable substantiated scenario generation.

Due to the comprehensive nature within the vision of biologicalisation, very few areas are currently accounted for. Not only does this highlight relatively unexplored areas and potential for development, but it also complements the roadmap towards biologicalisation by giving an indication of the large scope for research within it.

A database for biological transformation in manufacturing could be constructed by potentially applying the structure breakdown from **Figure 25** as a point of departure. Terminology and ethics for direct use of biological resources in manufacturing processes, for example bio-machining, are also required. Such a standard should include the use of biological organisms for lubrication. Also important are the safety and operating procedures, combined with respectful utilisation, contamination hazards, waste management, and sanitary issues.

Considering the current drive towards cybernetic implants and human augmentations, standards are also required in this regard. These should address ethical concerns, and especially concerns with regards to rules and regulations on military applications.

Standards on collaborative robots are under development (see **Table 3** in section 5.1). This supports the view that standards are especially important for industry, while researchers may be more liberal with their creative freedom. Standards are indispensable with regards to health and safety policies. Furthermore, global connectivity, and subsequent service availability would likely escalate the competitive market environments further beyond national borders. This is already evident today where consumers in developing countries make use of direct means to order products or services from abroad.

6 Recommendations

The recommendations for short-, medium-, and long-term activities are based on the content of this White Paper as well as on many reports, publications, investigations and reported industrial experience. They take into account the state of the art, the available knowledge and data, the development of new technologies, the market expectations as well as the standardisation, regulation and sustainability aspects. Account is also taken of the impact on education and the potential for biological transformation in manufacturing.

- **Recommendation 1:** Initiate programmes to develop collaboration between Biology and Engineering & Manufacturing

When recommending the application of biology in manufacturing having an emphasis on the integration of cyber-physical systems (CPS), digitalisation and Industry 4.0, awareness needs to be created concerning the associated interdisciplinary aspects.

Possibilities to use biology and nature to determine how manufacturing and/or products can be inspired must be systematically investigated.

The collaboration potential between biology, new manufacturing science and technology, and ICT needs to be investigated, developed and implemented.

It is further recommended that funding into CPS, digitalisation and Industry 4.0 should include the biologicalisation perspective.

- **Recommendation 2:** Strengthen national and international initiatives and collaborations.

It is recommended that national and international research initiatives be launched. This may involve collaborative projects with inter/transdisciplinary research and industry partners. This should be undertaken at national level, in the European community (e.g., EU) and/or worldwide. Pilot systems for industrial application cases should be developed.

Initiatives for lighthouse projects within the community and the setting up of alliances in specific countries or within organisations should be supported. A national BioMANU research agenda could lead to accelerated implementation of the new breaking frontier. Funding research into larger scale national institutions or funding international collaborations is essential, especially in topics where industry and private entrepreneurs hesitate to invest.

- **Recommendation 3:** Analyse the impact, the potential and the market opportunities of Biologicalisation in Manufacturing

It is necessary to carry out detailed and on-going market analysis to assess and analyse the potential of biology and biological systems for manufacturing. For the medium and long term, it is recommended that a survey to forecast trends in manufacturing and new developments in biology and manufacturing be carried out, e.g. in a Delphi type study. The results and conclusions can be used to build a database on potential biological principles, solutions, and opportunities for industrial application.

It is recommended to continue to develop structured methodologies and systematic approaches to analyse the potential of natural materials and natural principles for purposes of incorporation into manufacturing. In addition, it is suggested to proactively seek potential applications from thought leaders in communities outside of manufacturing but related to it or at the manufacturing interface.

The development of activities in artificial intelligence and machine learning from the bio-intelligent manufacturing perspective should be emphasised and investigated.

- **Recommendation 4:** Extend the standards and regulations and place a greater focus on Biologicalisation in Manufacturing

In addition to the already existing standards, covering mainly biomimetics structural optimisation, specific software packages and programming, as well as the biomimetics standards related to strategies, terminology, surfaces, robots, materials and structures [VDI 6220/1/2/3/4/5/6, ISO 18457/8, and DIN ISO 18459], listed in Table 3, there are still many deficiencies and requirements. It is recommended to expedite the drafting of new standards in order to streamline the resultant scientific literature by, amongst other things, eliminating ambiguity.

Since most of the available standards are related to Biomimetics, it is recommended to look at other unexploited areas and potential for innovation, such as direct use of biological resources, bio-economics, and future developments, which can complement the roadmap towards biologicalisation by giving an indication of the large scope for research activities. Furthermore, it is recommended to look into terminology and ethics for direct use of biological organisms and resources, for example lubricants and cutting fluids. It is also important that regulations be issued related to safety and operating procedures combined with utilisation and contamination of hazardous and waste materials.

- **Recommendation 5:** Stimulate educational and training Programmes as well as stakeholder and societal dialogue

It is recommended that the required skillsets of the future Biomanufacturing Engineer be defined, looking at the integration of mechanical and industrial engineering, ICT, human and social sciences as well as basic studies of biology, botany, and zoology. The education and training will be followed by research and development activities to be carried out in universities and industry within the range of biology and manufacturing. In order to ensure the next generation of open minded people and highly qualified teachers, postgraduate modules, e.g. masters in Biologicalisation in Manufacturing as well as PhD's and postdoctoral fellowships and special pedagogical programs should be introduced.

It is recommended that the facilitation of societal dialogue be initiated. In addition, international stakeholder dialogue and cross-sectoral collaboration to debate and analyse potential and market opportunities should be put in place. A platform similar in nature to that, which was set up for Industry 4.0 and learning systems would be appropriate for this area of Biologicalisation in Manufacturing.

- **Recommendation 6:** Develop a Roadmap for Biologicalisation in Manufacturing

The roadmap may be divided into different key areas such as:

- An academic research and development roadmap,
- A technological roadmap,
- An industrial roadmap and
- An awareness roadmap.

Projects encompassing all depths of maturity on the Technology Readiness Level (TRL) [EurComm, 2014] index should be instigated. Interdisciplinary academic projects (TRL 1-3, basic research) need initiation at national and international levels. Pre-competitive projects between industry clusters and academia (TRL 4-6) should also be initiated (e.g. prototyping). Dedicated product and manufacturing systems projects in the supply chain (at TRL 7-9, certification and upscaling) also need to be put in place.

It is necessary to create awareness in academia, industry and society through activities such as: media campaigns, conferences and exhibitions, vendor events etc. A knowledge infrastructure needs to be built and databases need development providing examples of Biologicalisation in Manufacturing.

It is essential that industrial activities be rolled out and that companies be supported in starting and sustaining industrial biomanufacturing projects with appropriate financial stimuli.

- **Recommendation 7:** Establish an umbrella project: Biologicalisation in Manufacturing

In collaboration with national and international academies and industries, it is recommended that a “Biologicalisation in Manufacturing” large scale project e.g. research cluster be established. This could be an umbrella project, covering a wide range of topics within the broad theme of Biologicalisation in Manufacturing. The participants, the potential, and the manner in which the project can be realised and implemented need to be addressed. In addition, the expectations and potential for new developments and innovations as well as the required investment need specification.

7 Conclusion

Based on the continuous increase of computing power and software capabilities, unprecedented transformations are taking place in manufacturing science and technology. In parallel, outstanding progress in biology, biotechnology, bio-intelligence and bio-inspired approaches has been taking place. In 2017, a new term entitled “Biologicalisation” emerged. In the early stages of a biological transformation some convergence is also occurring between biomimetics, biotechnology and the bioeconomy. While these areas are broader than the scope of this White Paper, it is important that the wider perspective beyond biological transformation in manufacturing be monitored and where appropriate be integrated.

The authors of this White Paper formulated a definition of Biologicalisation in Manufacturing as being:

“The use and integration of biological and bio-inspired principles, materials, functions, structures and resources for intelligent and sustainable manufacturing technologies and systems with the aim of achieving their full potential.”

The main conclusion is that it is convincing to maintain that Biologicalisation in Manufacturing truly represents a new and ground-breaking frontier of digitalisation and Industry 4.0. The market potential has been shown to be very strong. However, extensive research and development work as well as stimulation of industrial adoption are required to maximise the benefits of a systematic biological transformation in manufacturing.

Acknowledgements

The authors wish to acknowledge and thank Professor Reimund Neugebauer, President of the Fraunhofer-Gesellschaft, for his initiation of this project. They also thank the internal Fraunhofer team including Dr. Sophie Hippmann, Head of Think-Tank at Fraunhofer, Dr.

Marion Früchtl, Ms. Kerstin Funck and Dr. Patrick Dieckhoff for their strong input and continuous support and suggestions with this project. In addition, the authors thank Professor Thomas Bauernhansl and Mr. Robert Mieke of Fraunhofer IPA for their input.

The authors also wish to thank Professor Konrad Wegener of the ETH, Zürich, for his contribution and input to the literature review.

Project management was undertaken by Dr. James Ryle based at the Office of the Fraunhofer Senior Advisor (United Kingdom and Ireland) at University College Dublin, Ireland. Dr. Ryle did an outstanding job of management, coordination and guidance of the work, which was spread across 8 countries (Germany, Hungary, Ireland, Israel, Italy, South Africa, Switzerland and The Netherlands). The authors are particularly grateful to him for this commitment.

A workshop on Biologicalisation in Manufacturing took place in August 2017 in Lugano, Italy, in the surrounds of the General Assembly of the International Academy for Production Engineering (CIRP) and the authors thank the speakers and participants for their important input to this project.

References

- Schuh, G., Anderl, R., Gausemeier, J., ten Hompel, M., Wahlster W., (2017), Industrie 4.0 Maturity Index – Managing the Digital Transformation of Companies, Acatech, Berlin.
- Abu Qudeiri, J., Yamamoto, H., Ramli, R., (2007), Optimisation of operation sequence in CNC machine tools using genetic algorithm, *Journal of Advanced Mechanical Design, Systems, and Manufacturing*, 1(2): 272-282.
- Ahn, B.K., Das, S., Linstadt, R., Kaufman, Y., Martinez-Rodriguez, N.R., Mirshafian, R., Kesselman, E., Talmon, Y., Lipshutz, B.H., (2015), High-performance mussel-inspired adhesives of reduced complexity, *Nature Communications* 6:8663-9.
- Al Geddawy T., El Maraghy H., (2010), Co-evolution hypotheses and model for manufacturing planning, *CIRP Annals – Manufacturing Technology*, 59(1): 445-448.
- Autumn, K., Liang, Y.A., Hsieh, S.T., Zesch, W., Chan, W.-P., Kenny, W.T., Fearing, R., Full, R.J., (2000), Adhesive force of a single gecko foot-hair, *Nature*, 405: 681–5.
- Ball, P., (2012), Nature's Colour Tricks, *Scientific American*, 306: 74–9.
- Bartlett, M.D., Croll, A.B., King, D.R., Paret, B.M., Irschick, D.J., Crosby, A.J., (2012), Looking beyond fibrillar features to scale gecko like adhesion, *Advanced Materials*, 24 (8): 1078-83.
- Bartolo, P., Domingos, M., Gloria, A., Ciurana, J., (2011), BioCell printing: Integrated automated assembly system for tissue engineering constructs, *CIRP Annals – Manufacturing Technology*, 60(1): 271-274.
- Benyus, J.M., *Biomimicry: Innovations Inspired by Nature*. Quil. New York, 1977
- Benyus, J., (1997), *Biomimicry: Innovation Inspired by Nature*, William Morrow & Company, New York, USA.
- Bleckmann, H., Klein, A., Meyer, G. (2004). Nature as a model for technical sensors. *Journal of Comparative Physiology A, Neuroethology, Sensory, Neural and Behavioural Physiology*, 190(12): 971-981.
- Carson, J., (2015), Demonstrating High-Performance, Energy – Efficient Additive Manufacturing, the New York State, Energy Research and Development Authority.
- Chang, J.H., Hocheng, H., Chang, H.Y., Shih, A., (2008), Metal removal rate of *Thiobacillus thiooxidans* without pre-secreted metabolite. *Journal of Materials Processing Technology*, 201: 560-564.
- 3rd CIRP Conference on BioManufacturing - CIRP-BioM2017, Chicago, USA, 12-14 July 2017
- Cribb, W., Lin, C.-L., Rintoul, L., Rasch, R., Hasenpusch, J., Huang, H., (2010), Hardness in arthropod exoskeletons in the absence of transition metals, *Acta Biomaterialia*, 6: 3152-6.
- Dalavi, A.M., Pawar, P.J., Singh, T.P., (2016), Optimal sequence of hole-making operations using particle swarm optimisation and shuffled frog leaping algorithm, *Engineering Review*, 36(2): 187-196.
- D'Addona, D.M., Teti, R., (2013), Genetic algorithm-based optimization of cutting parameters in turning processes, *Procedia CIRP*, 7: 323-328.
- DIN_ISO_18459, 2016. *Biomimetics – Biomimetic structural optimization*. DIN_ISO_18459 Berlin: Beuth.
- El Maraghy, W. H., Urbanic, R.J., (2003), Modelling of manufacturing systems complexity, *CIRP Annals – Manufacturing Technology*, 52(1): 363-366.
- El Maraghy, W., El Maraghy, H., Tomiyama, T., Monostori, L., (2012), Complexity in engineering design and manufacturing, *CIRP Annals - Manufacturing Technology*, 61(2):793-814.
- Epstein, A.K., Pokroy, B., Seminara, A., Aizenberg, J., (2011), Bacterial biofilm shows persistent resistance to liquid wetting and gas penetration, *Proc. of the Nat. Acad. of Sciences of the USA*, 108(3): 995-1000.
- European Science Foundation, *Nature Inspired Science and Engineering for a Sustainable Future*. Science Policy Briefing, (September 2012). ISBN: 978-2-918428-73-2.
- European Commission, (2014), Technology readiness levels (TRL). URL: http://ec.europa.eu/research/participants/data/ref/h2020/other/wp/2016_2017/annexes/h2020-wp1617-annex-g-trl_en.pdf, Accessed: March 13, 2018.
- Fan, T.-X., Chow, S.-K., Zhang, D., (2009), Biomorphic mineralization: From biology to materials. *Progress in Materials Science*, 54(5): 542-659.
- Fang, F.Z., Zhang, Xiaodong, Gao, W., Guo, Y.B., Byrne, G., Hansen, H.N., (2017), Nanomanufacturing—Perspective and applications. *CIRP Annals - Manufacturing Technology*, 66(2): 683-705.
- Fatima, A., Mativenga, P., (2015), On the comparative cutting performance of nature-inspired structured cutting tool in dry cutting of AISI/SAE 4140. *Proceedings of the Institution of Mechanical Engineers, Part B: Journal of Engineering Manufacture*, 8 Pages.
- Ferminian Business & Economic Institute, P.L.N.U., *Bioinspiration: an economic progress report 2013*
- Floreano D., Mattiussi, C., *Bio-Inspired Artificial Intelligence*. MIT Press, 2008.
- Fraunhofer-Gesellschaft Think Tank, (2017), Internal Strategy presentation.
- Gao, Y., Ellery, A., Sweeting, M.N., (2007), Bioinspired drill for planetary sampling: Literature survey, conceptual design, and feasibility study. *Journal of Spacecraft and Rockets*, 44(3): 703-709.
- Goel, A.K., McAdams, D.A., Stone, R.B. editors. (2013), *The AskNature Database: Enabling Solutions in Biomimetic Design*. Biologically Inspired Design. Springer.
- Gleich, A., Pade, C., Petschow, U., Pissarskoi, E., (2002), *Potentials and Trends in Biomimetics*, Springer.
- Green T.B, *Tapping into Nature, the Future of Energy, Innovation, and Business*, (2016), URL: <http://www.terrabinbrightgreen.com/tapping-into-nature/> Accessed: September 5, 2017.
- Helfman Cohen, Y., Reich, Y., (2016), *Biomimetic Design Method for Innovation and Sustainability*, Springer.
- Helfman Cohen, Y., Reich, Y., Greenberg, S., (2014), Sustainability strategies in nature, *International Journal of Design & Nature and Ecodynamics*, 9(4): 285-95.
- Hocheng, H., Chang, J.H., Han, H.J., Chang, Y.L., Jadhav, U.U., (2012), Metal removal by *Acidithiobacillus ferrooxidans* through cells and extra-cellular culture supernatant in biomachining, *CIRP Journal of Manufacturing Science and Technology*, 5(2): 137-141.

- ISO_18457, 2016, Biomimetics – Biomimetic materials, structures and components, ISO_18457 Geneva: ISO.
- ISO_18458, 2015. Biomimetics—Terminology, Concepts and Methodology. ISO_18458 Berlin: Beuth.
- Istiyanto, J., Kim, M. Y., Ko, T. J., (2011), Profile characteristics of biomachined copper, *Microelectronic Engineering*, 88: 2614-2617.
- Jia, H., Li, C., Zhang, Z., Wang, G., (2013), Design of bionic saw blade for corn stalk cutting, *Journal of Bionic Engineering*, 10(4): 497-505.
- Jiang, W., (2014), Bio-inspired self-sharpening cutting tool surface for finish hard turning of steel. *CIRP Annals - Manufacturing Technology*, 63(1): 517-520.
- Keten, S., Xu, Z.P., Ihle, B., Buehler, M.J., (2010), Nanoconfinement controls stiffness, strength and mechanical toughness of β -sheet crystals in silk, *Nat. Mater.*, 9:359-367.
- Killian, C.E., (2011), Self-sharpening mechanism of the sea urchin tooth, *Advanced Functional Materials*, 21: 682–90.
- Kitano H., (2004), Biological robustness, *Nature Reviews Genetics*, (5):826-837.
- Kitano H., (2007), Towards a theory of biological robustness, *Molecular Systems Biology*, 3(1): 1-7.
- Klocke, F., (2015), Bio-inspired surfaces, CIRP Bio Inspired Materials Manufacturing Processes and Systems, CIRP GA Cape Town.
- Liu, K., Jiang, L., (2011), Bio-inspired design of multiscale structures for function integration, *NanoToday*, 6(2): 155-175.
- Lutters, D., van Houten, F., Bernard, A., Mermoz E., Schutte, C., (2014), Tools & techniques for product design, *CIRP Annals – Manufacturing Technology*, 63(2): 607-630.
- Lurie-Luke, E., (2014), Product and technology innovation: What can biomimicry inspire? *Biotechnology Advances Journal*, 32(8): 1494-1505.
- Mak, T., Shu, L., (2004), Abstraction of Biological Analogies for Design, *CIRP Annals – Manufacturing Technology*, 53(1): 117-20.
- Malshe, A., Rajurkar, K., Samant, A, Hansen, H.N., Bapat, S., Jiang, W., (2013), Bio-inspired functional surfaces for advanced applications, *CIRP Annals – Manufacturing Technology*, 62(2): 607-628.
- Maropoulos, P.G., Ceglarek D., (2010), Design verification and validation in product lifecycle, *CIRP Annals – Manufacturing Technology*, 59(2): 740- 759.
- Melkote, S.N, Grzesik, W., Outeiro, J., Rech, J., Schulze, V., Attia, H., Arrazola, P.J., M'Saoubi R., Saldana, C., (2017), Advances in material and friction data for modelling of metal machining, *CIRP Annals – Manufacturing Technology* 66(2): 731-754.
- Mendes, A. C., Baran, E. T., Reis, R. L., Azevedo, H. S. (2013). Self-assembly in nature: Using the principles of nature to create complex nanobiomaterials. *Wiley Interdisciplinary Reviews: Nanomedicine and Nanobiotechnology*, 5(6): 582-612.
- Meyer, D., Redetzky, M., Brinksmeyer, E., (2017), Microbial-based metalworking fluids in milling operations. *CIRP Annals – Manufacturing Technology*, 66(1): 129-132.
- Mirkin, C. A. M., (2017), Programming the formation of optically-active colloidal crystals with DNA, *3rd CIRP Conference on BioManufacturing - CIRP-BioM2017*, Chicago, USA, 12-14 July 2017.
- Mitsuishi, M., Cao, J., Bártolo, P., Friedrich, D., Shih, A.J., Rajurkar, K., Sugita, N., Harada, K., (2013), Biomanufacturing, *CIRP Annals – Manufacturing Technology*, 62(2): 585-606.
- Monostori, L., Barschdorff, D., (1992), Artificial neural networks in intelligent manufacturing, *Robotics and Computer-Integrated Manufacturing*, 9(6): 421-437.
- Monostori, L., Márkus, A., Van Brussel, H., Westkämper, E., (1996), Machine learning approaches to manufacturing, *CIRP Annals – Manufacturing Technology*, 45(2): 675-712.
- Monostori, L., Váncza, J., Kumara, S.R., (2006), Agent-based systems for manufacturing, *CIRP Annals – Manufacturing Technology*, 55(2): 697-720.
- Monostori, L., Kádár, B., Bauernhansl, T., Kondoh, S., Kumara, S., Reinhart, G., Sauer, O., Schuh, G., Sihn, W., Ueda, K., (2016), Cyber-physical systems in manufacturing, *CIRP Annals – Manufacturing Technology*, (65)2: 621-641.
- Monostori, J., (2016), Robustness- and complexity-oriented characterization of supply networks' structures, *Procedia CIRP*, 57:67-72.
- Monostori, J., (2018), Supply chains' robustness: Challenges and opportunities. *Procedia CIRP*, 67:110-115.
- Montiel-Ross, O., Medina-Rodríguez, N., Sepúlveda, R., Melin, P., (2012), Methodology to optimize manufacturing time for a CNC using a high-performance implementation of ACO, *International Journal of Advanced Robotic Systems*, 9(121): 1-10.
- Nee, A.Y.C., Ong, S.K., Chryssolouris, G., Mourtzis D., (2012), Augmented reality applications in design and manufacturing, *CIRP Annals – Manufacturing Technology*, 61(2): 657-679.
- Neugebauer, R., Drossel, W.-G., Ihlenfeldt, S., Harzbecker, Ch., (2009), Design method for machine tools with bionic inspired kinematics, *CIRP Annals – Manufacturing Technology* 58(1):371-374.
- Neugebauer, R., Wabner, M., Ihlenfeldt, S., Friess, U., Schneider, F., Schubert, F., (2012), Bionics based energy efficient machine tool design, *Procedia CIRP*, 3: 561-566.
- Parker, C.A., Zhang, H., Kube, C.R., (2003), Blind bulldozing: Multiple robot nest construction, *Proceedings of International Conference on Intelligent Robots and Systems*. Las Vegas.
- Reap, J., Baumeister, D., Bras, B. (2005), Holism, biomimicry and sustainable engineering. *Proceedings of IMECE2005*. Orlando.
- Reisen K., Teschemachjer U., Niehues M., Reinhart G., (2016), Biomimetics in production organization – A literature study and a framework. *Journal of Bionic Engineering*, 13:200-212.
- Rodrigue, H., Rivette, M., (2010), An assembly-level design for additive manufacturing methodology, *Proceedings of IDMMME - Virtual Concept*, (pp. 1-9). Bordeaux.
- Schatten, M., Zugaj, M., (2011), Biomimetics in modern organizations – Laws or metaphors? *Interdisciplinary Description of Complex Systems*, 9(1): 39-55.
- Scheibel, T., (2004), Spider silks: recombinant synthesis, assembly, spinning, and engineering of synthetic proteins, *Microbial Cell Factories*, 3: 14-28.
- Shen, S., (2017), Patented high-strength fibers from synthetic spider silk, Seevix Material Sciences, Executive Summary, pages 1-2.

- Scholz-Reiter, B., Freitag, M., (2007), Autonomous processes in assembly systems, *CIRP Annals – Manufacturing Technology*, 56(2): 712-729.
- Shu, L.H., Ueda, K., Chiu, I., Cheong, H., (2011), Biologically inspired design, *CIRP Annals – Manufacturing Technology*, 60(2): 673-693.
- Solga, A., Cerman, Z., Striffler, B.F., Spaeth, M., Barthlott, W., (2007), The dream of staying clean: Lotus and biomimetic surfaces, *Bioinspiration & Biomimetics*, 2(4): 126-9.
- Stroble, J., Stone, R., Watkins, S., (2009), An overview of biomimetic sensor technology, *Sensor Review*, 29(2), 112-119.
- Suh, N.P., Cochran, D.S., Lima, P.C., (1998), Manufacturing System Design, *CIRP Annals – Manufacturing Technology*, 47(2): 627-639
- Suh, N.P., (2005), Complexity in engineering, *CIRP Annals – Manufacturing Technology*, 54(2): 581- 598.
- Surana A., Kumara S., Greaves M., Raghavan, U.N., (2005), Supply chain networks: A complex adaptive systems perspective, *International Journal of Production Research*, 43(20):4235-4365.
- Syntia, E., Alam, P., (2016), Self-assembled semi-crystallinity at parallel sheet nanocrystal interfaces in clustered MaSp1 (spider silk) proteins, *Mat. Sci. Eng.*, 58: 366-71.
- Tamjidy, M., Paslar, S., Hang, B. T., Baharudin, T., Hong, T. S., Ariffin, M.K., (2015), Biogeography based optimisation (BBO) algorithm to reduce non-productive time during hole-making process, *International Journal of Production Research*, 53(6), 1880-1894.
- Tero, A., Takagi, S., Saigusa, T., Ito, K., Bebbber, D.P., Fricker, M.D., Yumiki, R., Nakagaki, T., (2010), Rules for biologically inspired adaptive network design, *Science*, 327:439-442.
- Teti, R., Kumara, S.R.T., (1997), Intelligent computing methods for manufacturing systems, *CIRP Annals – Manufacturing Technology*, 46(2): 629-652
- Thompson, M.K., Moroni, G., Vaneker, T., Fadel, G., Campbell, R.I., Gibson, I., Bernard A., Schulz, J., Graf, P., Ahuja, B., Martina, F., (2016), Design for additive manufacturing: Trends, opportunities, considerations and constraints, *CIRP Annals – Manufacturing Technology*, 65(2): 737-760.
- Tillmann, W., Hagen, L., Stangier, D., Laemmerhirt, I.-A., Biermann, D., Kersting, P., Krebs, E., (2015), Wear behavior of bio-inspired and technologically structured HVOF sprayed NiCrBSiFe coatings, *Surface and Coatings Technology*, 280: 16-26.
- Tolio, T., Ceglarek, D., El Maraghy, H.A., Fischer, A., Hu, S.J., Laperriere, L., Newmann, S.T., Vancza, J., (2010), SPECIES—Co-evolution of products, processes and production systems, *CIRP Annals – Manufacturing Technology*, 59(2): 672-693.
- Ueda, K., Vaario J., Ohkura K., (1997), Modelling of biological manufacturing systems for dynamic reconfiguration, *CIRP Annals – Manufacturing Technology*, 46(1): 343-346.
- Ueda, K., Hatono, I., Fujii, N., Vaario, J., (2000), Reinforcement learning approaches to biological manufacturing systems, *CIRP Annals – Manufacturing Technology*, 49(1): 343-346.
- Ueda, K., Hatono, I., Fujii, N., Vaario, J., (2001), Line-less production system using self-organization: A case study for BMS, *CIRP Annals – Manufacturing Technology*, 50(1): 319-322.
- Ueda, K., Fujii, N., Hatono, I., Kobayashi, M., (2002), Facility layout planning using self-organization method, *CIRP Annals – Manufacturing Technology* 51(1): 399-402.
- Ueda, K., (1992), A concept for Bionic Manufacturing Systems based on DNA-type information. In *IFIP 8th International PROLAMAT Conference*, 853-863.
- Ueda, K., (1992), An approach to bionic manufacturing systems based on DNA-type information, *Proceedings of the ICOOMS'92*, 303-308.
- Vaario, J., Ueda, K., (1996), Self-organization in manufacturing systems. In *Japan-USA Symposium on Flexible Automation*, (2):1481-1484.
- Valckenaers, P., Van Brussel, H., (2005), Holonic manufacturing execution systems, *CIRP Annals – Manufacturing Technology*, 54(1): 427-432.
- Valckenaers, P., Van Brussel, H., (2015), Design for the unexpected, from holonic manufacturing systems towards a humane mechatronics society. Elsevier.
- Van Brussel, H., Wyns, J., Valckenaers, P., Bongaerts, L., Peeters, P., (1998), Reference architecture for holonic manufacturing systems: PROSA. *Computers in Industry*, 37:255-274.
- VDI_6220, 2012. Bionik: Konzeption und Strategie—Abgrenzung zwischen bionischen und konventionellen Verfahren/Produkten; Biomimetics: Conception and Strategy—Differences between Biomimetics and Conventional Methods/Products. VDI_6220 Berlin: Beuth.
- VDI_6221, 2013. Biomimetics - Biomimetic surfaces. VDI_6221 Berlin: Beuth.
- VDI_6222, 2013. Biomimetics - Biomimetic robots. VDI_6222 Berlin: Beuth.
- VDI_6223, 2013. Biomimetics - Biomimetic materials, structures and components. VDI_6223 Berlin: Beuth.
- VDI_6224, 2012. Biomimetic optimization. VDI_6224 Berlin: Beuth.
- Warnecke, H.-J., (1992), Die fraktale Fabrik: Revolution der Unternehmenskultur. Berlin, New York: Springer-Verlag; 1992.
- Wegener, K., (October 2017) Internal report to Fraunhofer.
- Werfel, J., Kirstin Petersen, K., Nagpal, R., (2014), Designing collective behaviour in a termite-inspired robot construction team. *Science*, 343(6172): 754-758.
- Xia, D., Johnson, L., López, G., (2012), Anisotropic wetting surfaces with one-dimensional and directional structures: fabrication approaches, wetting properties and potential applications, *Advanced Materials*, 24: 1287-302.
- Yao, Y., Wang, Q., Wang, H., Zhang, B., Zhao, C., Wang, Z., Xu, Z., Wu, Y., Huang, W., Qian, P.-Y., Zhang, X.X., (2013), Bio-assembled nanocomposites in conch shells exhibit giant electret hysteresis, *Advanced Materials*, 25: 711-8.
- Young, R.J., Deng, L., Gong, L., Kinloch, I.A., (2013), Carbon in Polymer, Vajtai R. (eds), Springer Handbook of Nanomaterials.
- Zhang, C., Lin, P. (2012). The bionic vibration damping technology and its inspiration for the high speed milling cutter, *Applied Mechanics and Materials*, 226-228, 98-101.
- Zheng, Y., Bai, H., Huang, Z., Tian, X., Nie, F.-Q., Zhao, Y., Zhai, J., Jiang, L., (2010), Directional water collection on wetted spider silk, *Nature*, 463: 640-3.

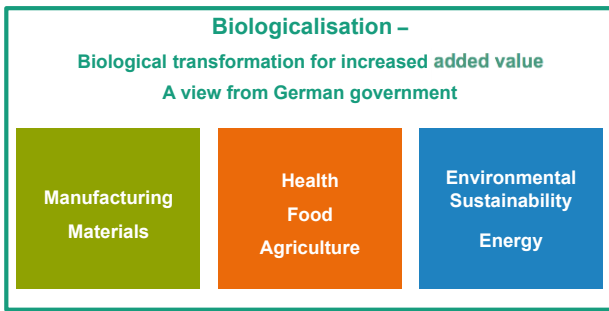

Figure 1: The main pillars of biologicalisation [Fraunhofer, 2017].

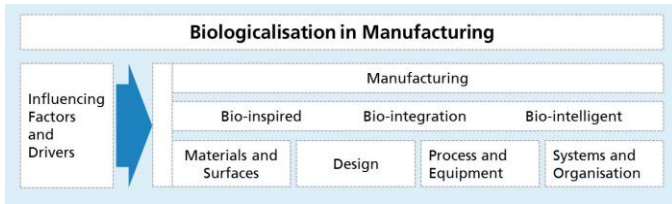

Figure 2: Scope of work addressed in this White Paper.

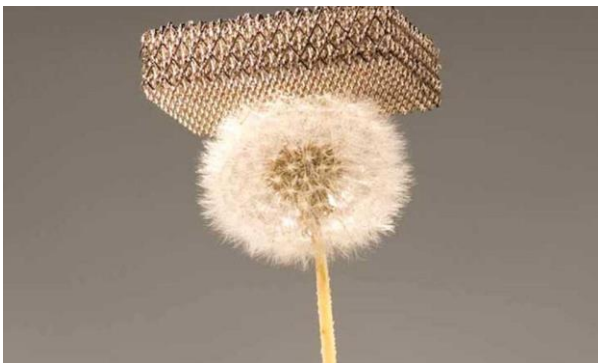

Figure 3: Example of newly developed metal structures which are extremely light and exhibit enhanced mechanical properties (Boeing).

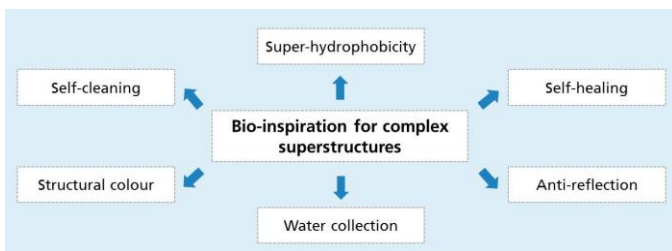

Figure 4: Bio-inspiration in multifunctional materials for products with remarkable capabilities and functions.

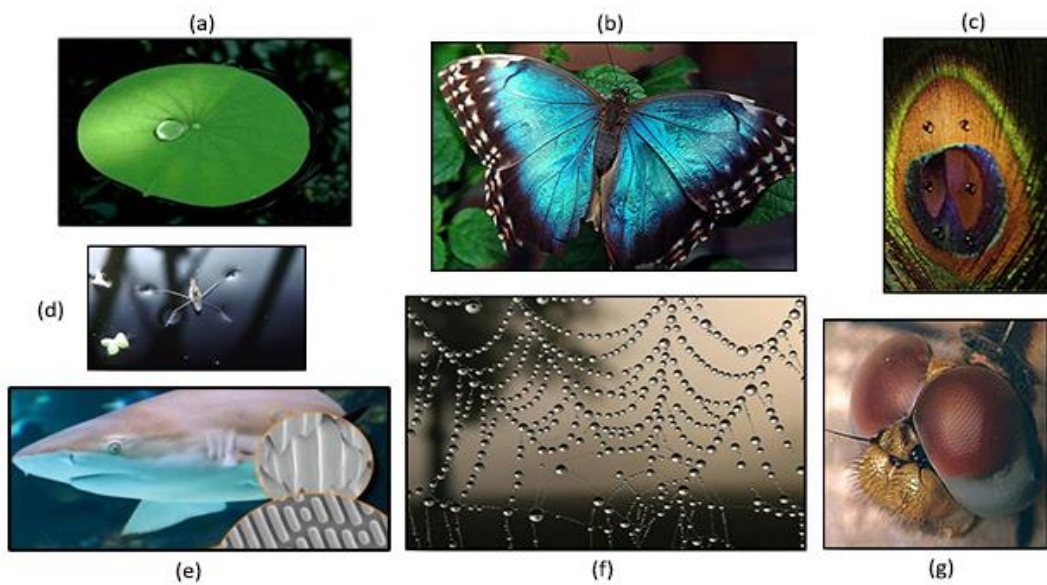

Figure 5: Inspiration from nature at the nanometer scale: (a) lotus leaf; (b) Morpho butterfly wings; (c) peacock feather (d) water strider legs (e) shark skin (f) spider capture/dragline silk; (g) moth compound eyes.

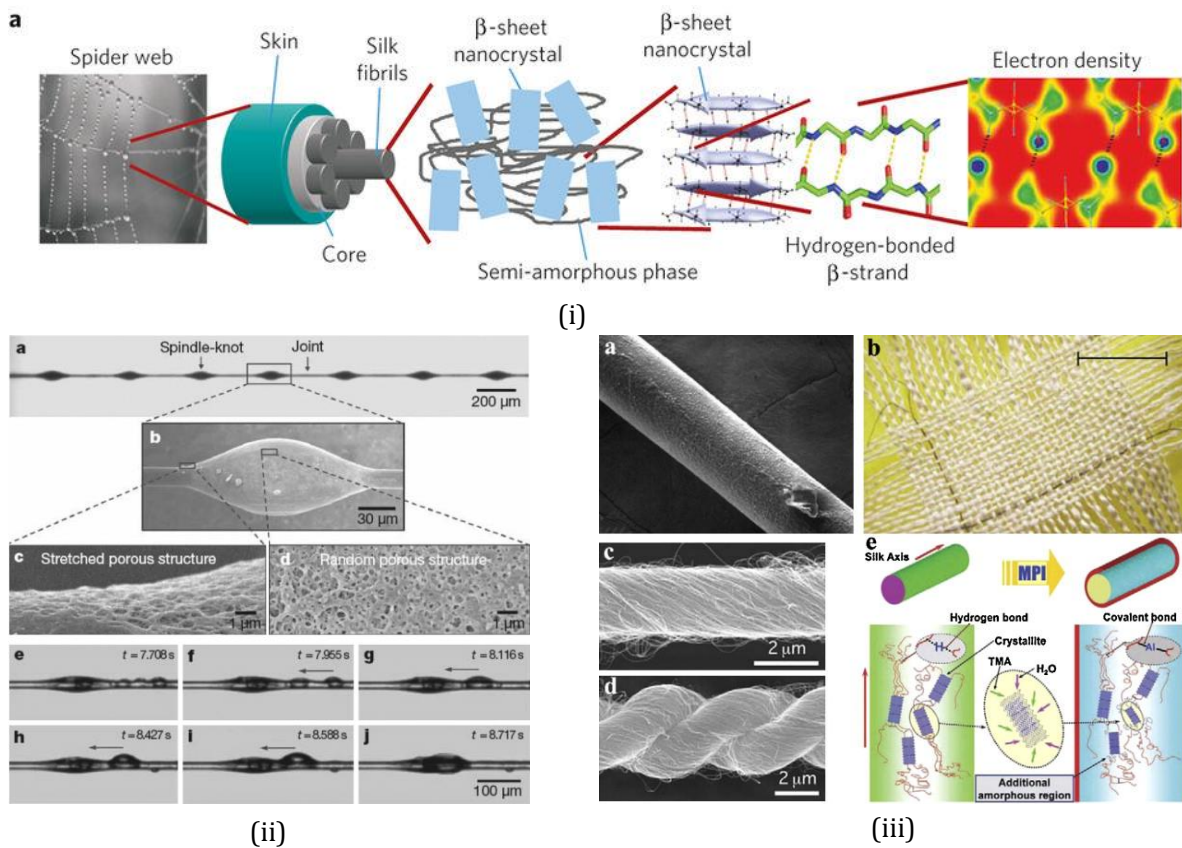

Figure 6: Artificial spider silks. (i) Artificial spider silks fabrication providing [Keten et al., 2010] (ii) water collection capability [Zheng et al., 2010] and (iii) high mechanical properties [Liu et al., 2011].

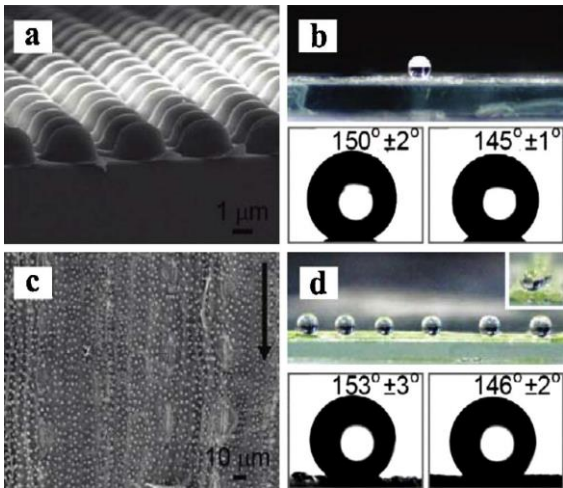

Figure 7: Artificial surface inspired by rice leaf providing both super-hydrophobicity and anisotropic wettability [Xia et al., 2012].

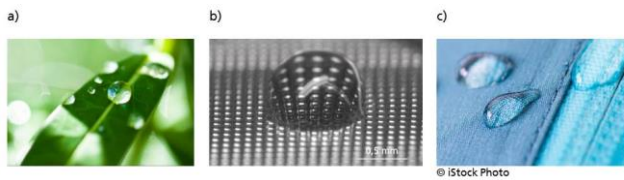

Figure 8: Lotus leaves provide super-hydrophobic properties for self-cleaning; appropriate surface treatments of textiles can reproduce these functions.

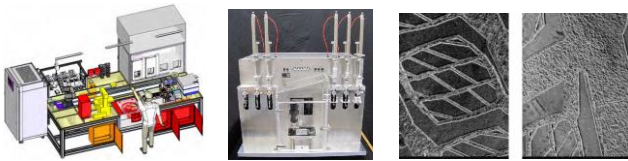

Figure 9: 3D printing of human tissue (Fraunhofer IPT/CMI).



Figure 10: Robird by Clear Flight Solutions: An artificial falcon to chase birds away from airports.

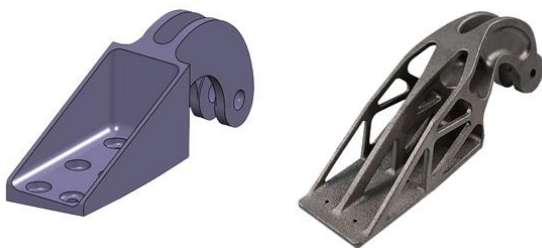

Figure 11: Manufacturing for Design.



Figure 12: Bio-inspired Unique Circle Yacht designed by Zaha Hadid Architects for Blohm + Voss.

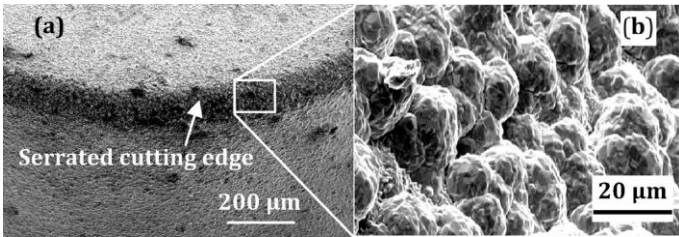

Figure 13: Biomimetic tools: (a) cutting edge with serrated ‘tips’; (b) an assembly of the tips forming the surface features of a lotus leaf and showing the periodicity of the micron tips [Jiang, 2014].

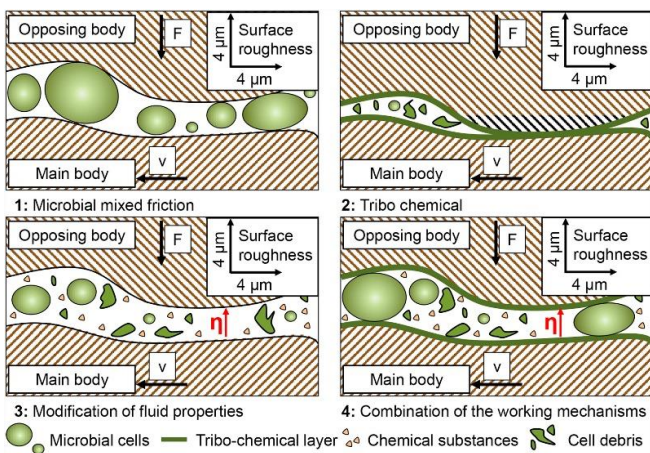

Figure 14: Possible working mechanisms of the microbial-based metalworking fluid [Meyer et al., 2017].

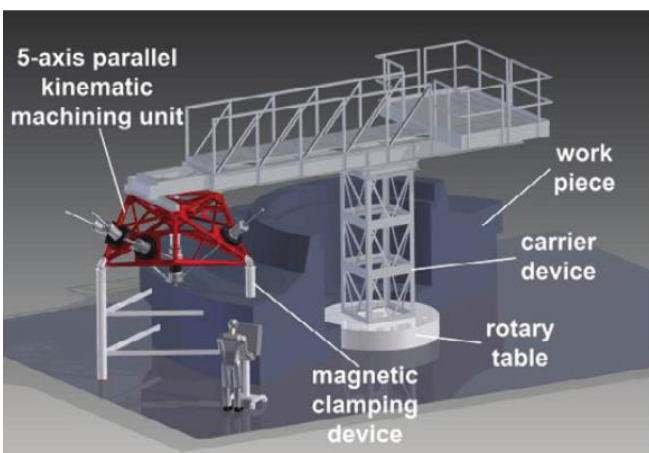

Figure 15: Modular mobile 5-axis parallel kinematic machine tool [Neugebauer et al., 2012].

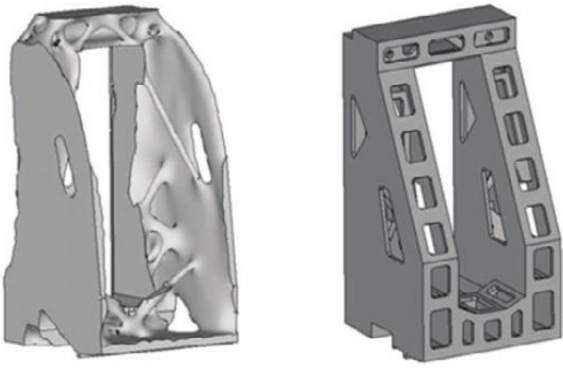

Figure 16: Topological optimisation of a machine stand (left) and the technical interpretation (right) [Neugebauer et al., 2012].

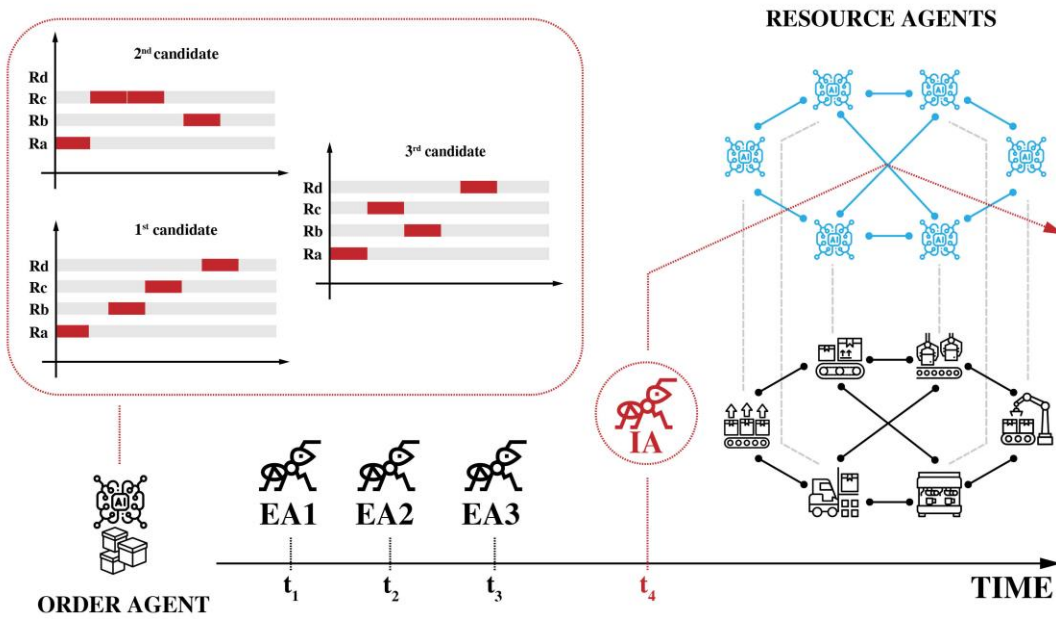

Figure 17: Ant agents scout for solutions on behalf of their order agent in a manufacturing execution system (EA: exploring ant, IA: intention ant) adapted from [Valckenaers et al., 2005].

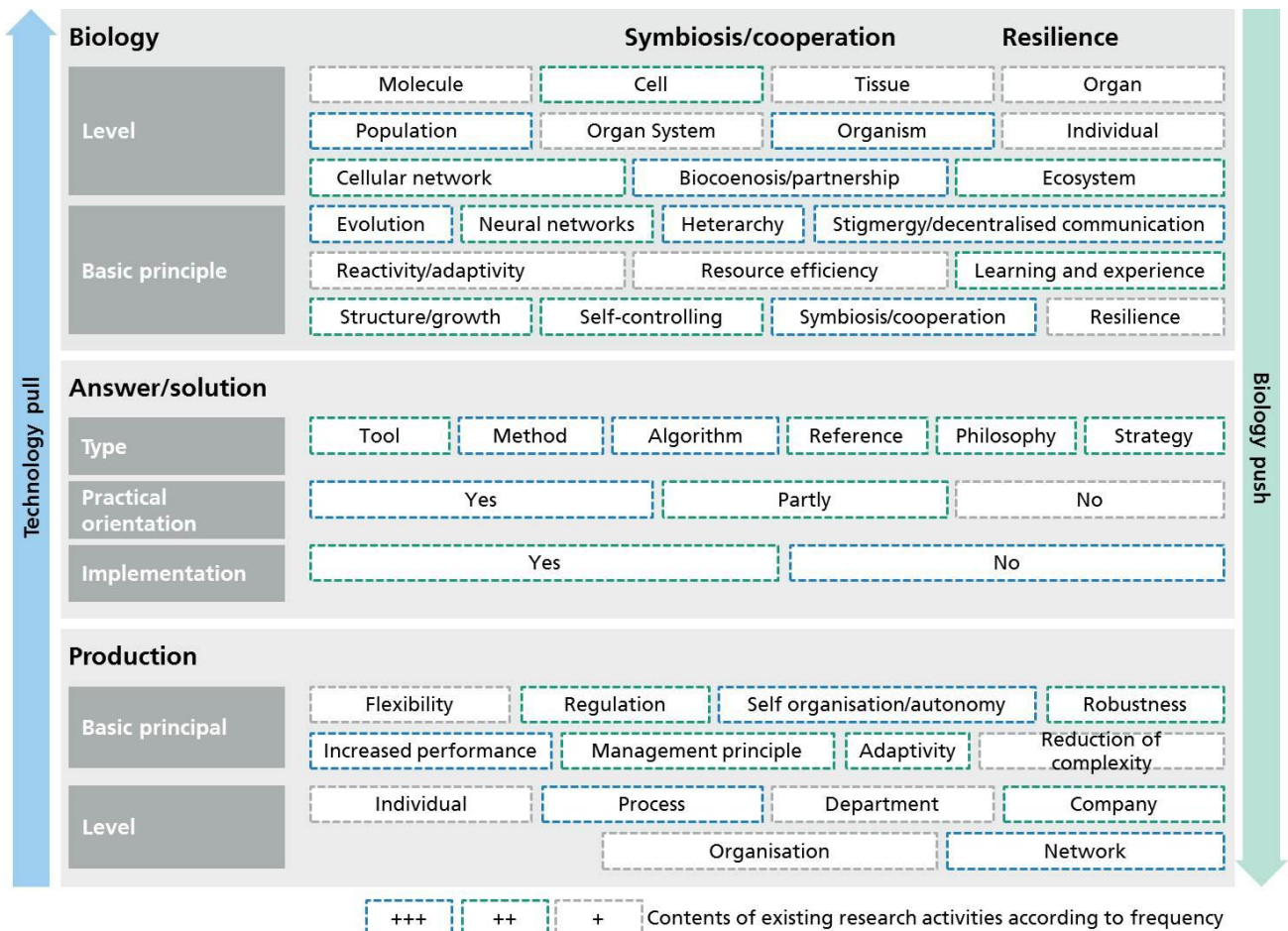

Figure 18: Framework providing an overview of existing research approaches in the field of biomimetic solutions to production structures (figure adapted from [Reisen et al., 2016]).

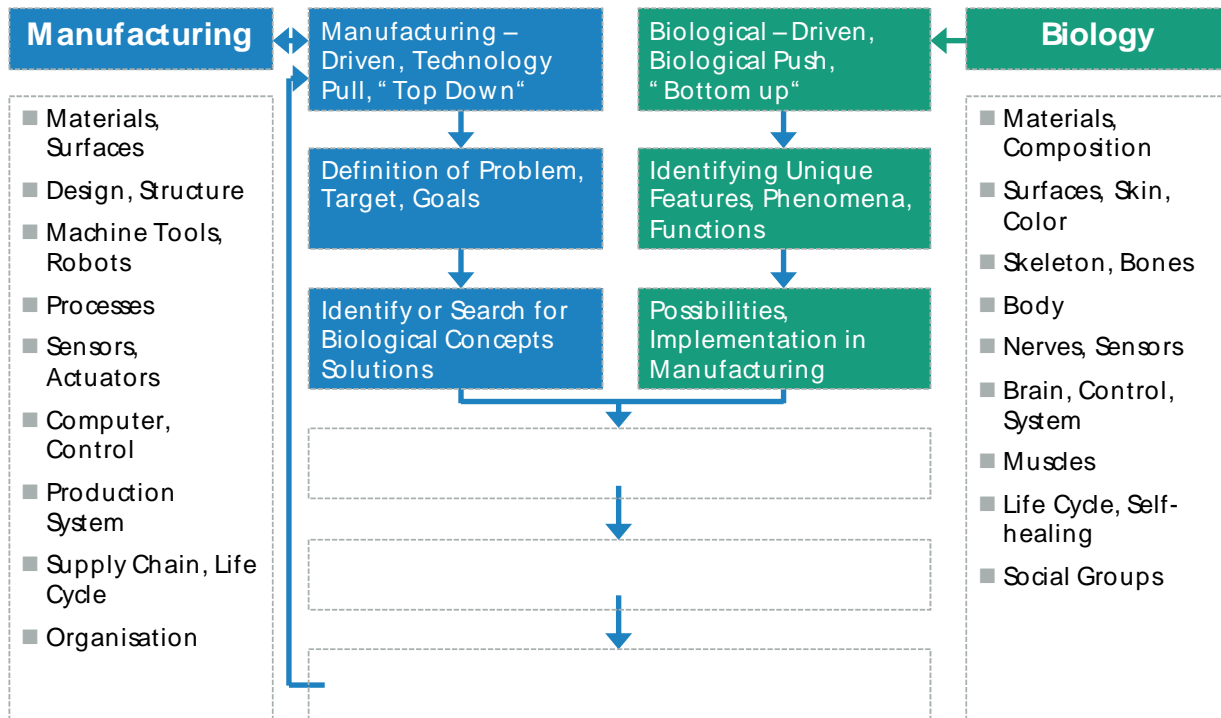

Figure 19: The bi-directional systematic approach to identify the potential and impact of Biologicalisation in Manufacturing.

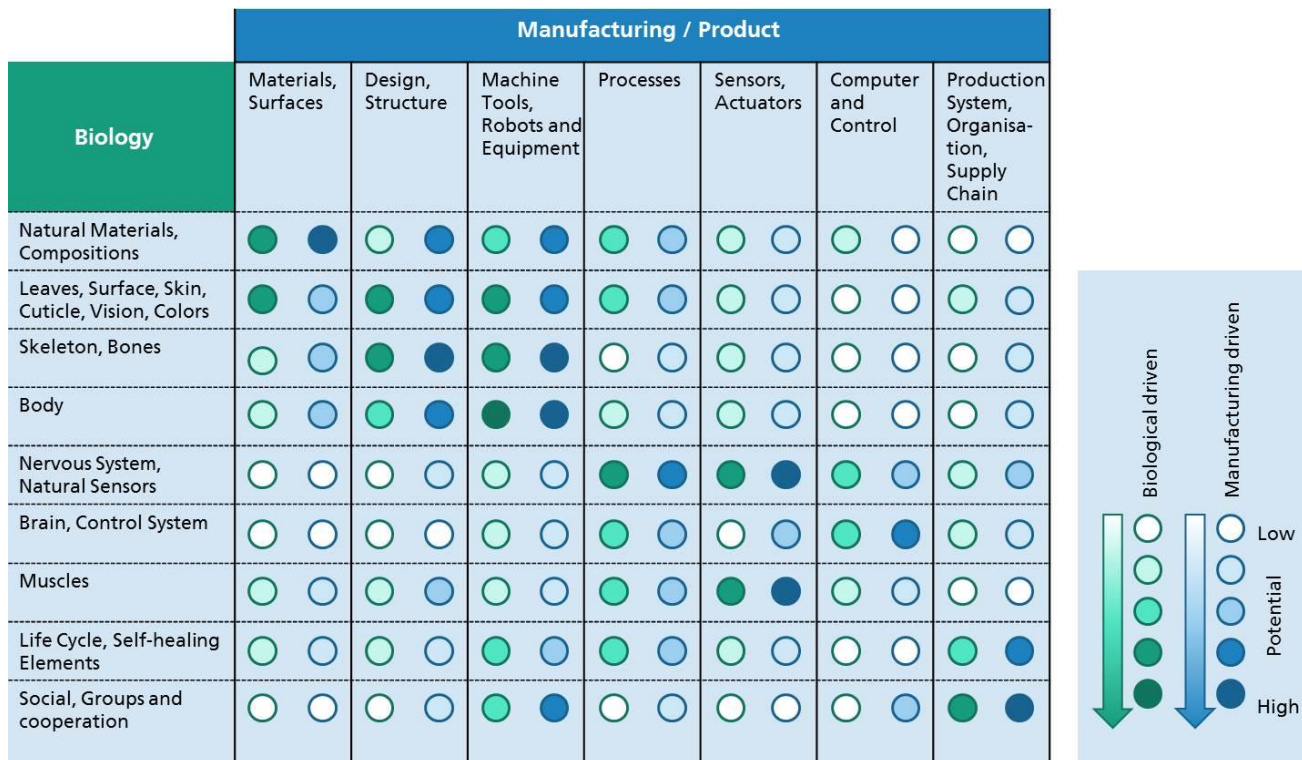

Figure 20: Example (for illustration purposes only) of an evaluation method to assess the potential and impact of applying biological transformation in manufacturing

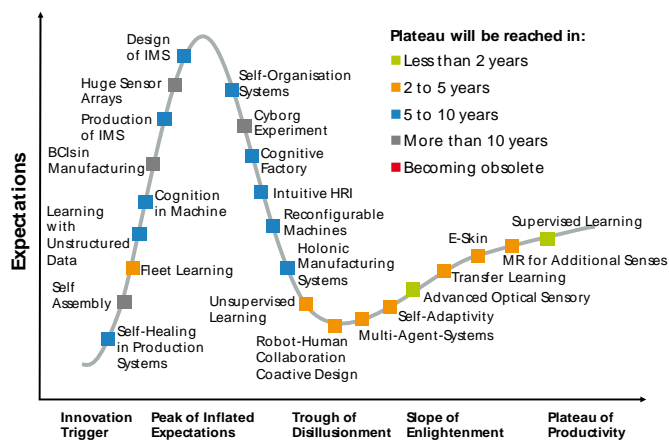

Figure 21: Gartner Hype Cycle for Biologicalisation in Manufacturing [Wegener, 2017].

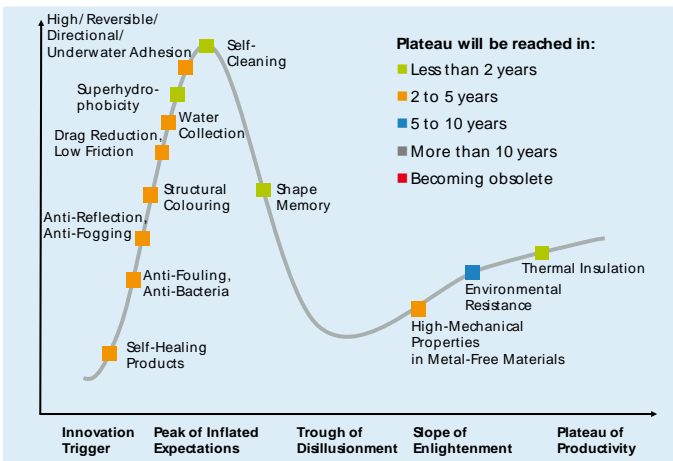

Figure 22: Gartner Hype Cycle for applications and expectations for materials and surfaces prepared by the authors.

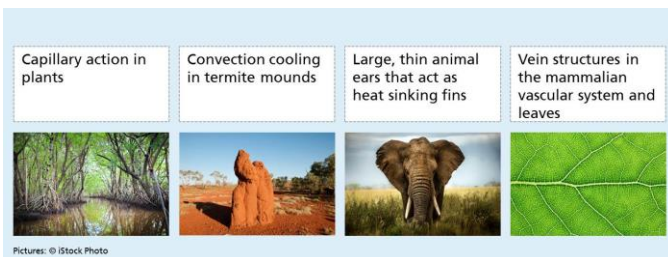

Figure 23: Evaluation of biological systems used for optimisation of cooling channels of an injection moulding die produced by additive manufacturing [Carson, 2015].

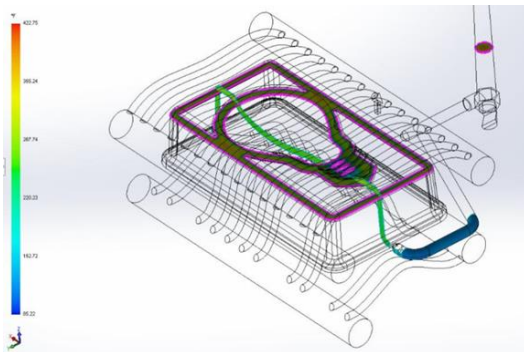

Figure 24: Optimised coolant channels of an injection moulding die, based on the dicot leaves structure, produced by AM [Carson, 2015].

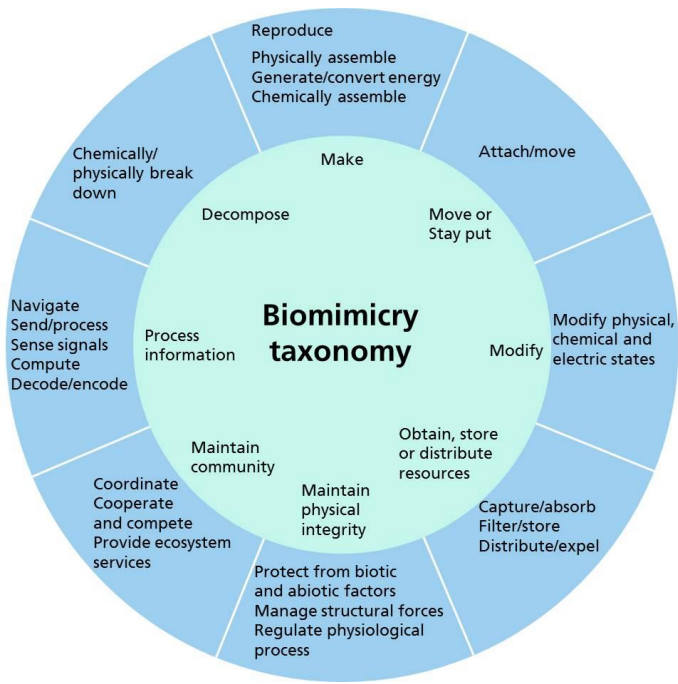

Figure 25: Biomimetic research topics categorised with biomimicry taxonomy, recreated from Goel et al [Goel et al., 2013].

Table 1: Description of biological characteristics and the relationship to engineering (adapted from [Reap et al., 2005]).

Biological Characteristics	Description	Related Engineering Solutions
In biology products are built from the bottom-up	The fundamental building blocks of any biological structure or material are assembled through manipulation and organisation of these blocks. Building blocks such as proteins or ions in aqueous solutions typically are of much smaller scales than the final structure or material. Evidence for this exists in the workings of cells, in the hierarchical organization of organisms, and in ecosystem structure.	Additive Manufacturing, Mass Customisation
In biology form is fit to function	The use of limited materials and metabolic energy to create structures and execute only the processes that are necessary for the functions required of an organism in a particular environment. Evidence for this exists on the protein, cellular and macroscopic levels in animals and plants.	General Design Theory, Topology Optimisation
In biology life is cyclic and recycling occurs	Cyclic processes occur as time goes on. Cycles of day and night, seasons, and even droughts arise. Also every organism goes through a life cycle. Recycling in biology refers to the decomposition, redistribution, and reuse of organic matter. All of these occurrences are recognised as critical features of the biosphere.	Recycling, Remanufacturing, Design for Disassembly (DfD), Industrial Ecology
In biology organisms adapt and evolve	Adaptation and evolution allow organisms to exist within the constraints imposed on them by their respective environments. Adaptation refers to the behavioural and material changes specific organisms make within a life cycle. Evolution refers to the slower, fundamental changes that occur over the course of many generations.	Control Systems Engineering, Robustness, Open Engineering Systems
In biology organisms coexist in a cooperative framework	The diverse web of interactions that facilitate resource transfers, effect populations, maintain the biosphere and ensure redundancy coexist within a cooperative framework.	Manufacturing Systems, Supply Chains, Industrial Ecology

Table 2: Materials and methods or processes to create biology-inspired superstructures.

Materials	Methods/Processes	Properties/Functions of Bio-Inspired Structures
Fabrics	Sol-gel and electrospinning	Super-hydrophobicity, thermal stability
Glass	Sol-gel	Hydrophobic, anti-reflective, self-cleaning, anti-fogging
Glass slide	Multi-beam Interference lithography	Super-hydrophobicity, iridescence
Nickel	Electrodeposition	Super-hydrophobicity, low friction
PAH-PEEK/PAA (polyallylamine hydrochloride (PAH) -sulfonated polyether ether ketone) (SPEEK) / polyacrylic acid (PAA))	Layer-by-layer (LBL) deposition	Super-hydrophobicity, self-healing functions
PDMS (polydimethylsiloxane)	Soft-lithography	Super-hydrophobicity, actuation, sensing capabilities
PUA (polyurethane acrylate)	Photopolymerisation and dry etching	Anti-reflection, anti-fogging
Silicon wafer	Electron beam lithography	Robust super-hydrophobicity, low friction
Silica	Colloidal lithography	Super-hydrophobicity, anti-reflection
Silica	Layer-by-layer (LBL) assembly	Self-cleaning, anti-reflection
Silicon	Reactive ion etching	Self-cleaning, anti-reflection
UPy (2-ureido-4[1H]- pyrimidone)	Multistep organic synthesis	Mechanical properties, self-healing, shape memory
ZnO (zirconium oxide)	Etching	Super-hydrophobicity, anti-reflection
CFRP (carbon fibre reinforced plastic)	Fibre layout and resin polymerisation	Very high specific mechanical properties, shape memory
Single-walled carbon nanotubes (SWNTs)-polyvinyl alcohol (PVA) composite fibres	Spinning	Water collection

Table 3: Current standards on biomimetics designation.

Designation	Title	Year
VDI 6220	Biomimetics: Conception and strategy—Differences between biomimetics and conventional methods/products	2012
VDI 6221	Biomimetics: Biomimetic surfaces	2013
VDI 6222	Biomimetics: Biomimetic robots	2013
VDI 6223	Biomimetics: Biomimetic materials, structures and components	2013
VDI 6224/1	Biomimetics: Biomimetic optimisation—Application of evolutionary algorithms	2012
VDI 6224/2	Biomimetics: Biomimetic optimisation—Application of biological growth laws for the structure mechanical optimisation of technical components	2012
VDI 6224/3	Biomimetics: Integrated product development process for biomimetic optimisation	2016
VDI 6225	Biomimetics: Biomimetic information processing	2012
VDI 6226	Biomimetics: Architecture, civil engineering, industrial design—basic principles	2015
ISO 18457	Biomimetics: Biomimetic materials, structures and components	2016
ISO 18458	Biomimetics: Terminology, concepts and methodology	2015
DIN ISO 18459	Biomimetics: Biomimetic structural optimization	2016
ISO/TS 15066	Robots and robotic devices -- Collaborative robots (in development)	2016
ISO 14708-3	Implants for surgery -- Active implantable medical devices -- Part 3: Implantable neuro-stimulators	2017