



<b>Title</b>	Wideband electrostatic Vibration Energy Harvester (e-VEH) having a low start-up voltage employing a high-voltage integrated interface
<b>Authors(s)</b>	Dudka, Andrey, Basset, Philippe, Cottone, Francesco, Blokhina, Elena, Galayko, Dimitri
<b>Publication date</b>	2013-12
<b>Publication information</b>	Dudka, Andrey, Philippe Basset, Francesco Cottone, Elena Blokhina, and Dimitri Galayko. "Wideband Electrostatic Vibration Energy Harvester (e-VEH) Having a Low Start-up Voltage Employing a High-Voltage Integrated Interface." IOP Publishing, December 2013. <a href="https://doi.org/10.1088/1742-6596/476/1/012127">https://doi.org/10.1088/1742-6596/476/1/012127</a> .
<b>Conference details</b>	PowerMEMS, The 13th International Conference on Micro and Nanotechnology for Power Generation and Energy Conversion Applications, 3-6 December, London, UK
<b>Publisher</b>	IOP Publishing
<b>Item record/more information</b>	<a href="http://hdl.handle.net/10197/5400">http://hdl.handle.net/10197/5400</a>
<b>Publisher's statement</b>	Content from this work may be used under the terms of the Creative Commons Attribution 3.0 licence. Any further distribution of this work must maintain attribution to the author(s) and the title of the work, journal citation and DOI.
<b>Publisher's version (DOI)</b>	10.1088/1742-6596/476/1/012127

Downloaded 2026-05-01 23:34:23

The UCD community has made this article openly available. Please share how this access benefits you. Your story matters! (@ucd\_oa)



© Some rights reserved. For more information

# Wideband Electrostatic Vibration Energy Harvester (e-VEH) Having a Low Start-Up Voltage Employing a High-Voltage Integrated Interface

A. Dudka<sup>1\*</sup>, P. Basset<sup>2</sup>, F. Cottone<sup>2</sup>, E. Blokhina<sup>3</sup>, D. Galayko<sup>1</sup>

<sup>1</sup>LIP6-UPMC – Sorbonne, France,

<sup>2</sup>Université Paris-Est, ESYCOM, ESIEE Paris, France

<sup>3</sup>UCD, Ireland

E-mail: \*andrii.dudka@lip6.fr

**Abstract.** This paper reports on an electrostatic Vibration Energy Harvester (e-VEH) system, for which the energy conversion process is initiated with a low bias voltage and is compatible with wideband stochastic external vibrations. The system employs the auto-synchronous conditioning circuit topology with the use of a novel dedicated integrated low-power high-voltage switch that is needed to connect the charge pump and flyback - two main parts of the used conditioning circuit. The proposed switch is designed and implemented in AMS035HV CMOS technology. Thanks to the proposed switch device, which is driven with a low-voltage ground-referenced logic, the e-VEH system may operate within a large voltage range, from a pre-charge low voltage up to several tens volts. With such a high-voltage e-VEH operation, it is possible to obtain a strong mechanical coupling and a high rate of vibration energy conversion. The used transducer/resonator device is fabricated with a batch-processed MEMS technology. When excited with stochastic vibrations having an acceleration level of 0.8 g rms distributed in the band 110-170 Hz, up to 0.75  $\mu$ W of net electrical power has been harvested with our system. This work presents an important milestone in the challenge of designing a fully integrated smart conditioning interface for the capacitive e-VEHs.

## 1. Introduction

The kinetic vibrations present in many environments are potential sources for the supply of autonomous microsystems. The Vibration Energy Harvesters based on electrostatic transducers (e-VEHs) are particularly suitable for miniature systems based on integrated CMOS and MEMS technologies. This, in turn, enables the integration of the transducer/resonator on the unique silicon substrate together with power processing and communication electronics.

To achieve a mechanical energy conversion, a conditioning circuit charges and discharges the transducer capacitance synchronously with the transducer capacitance variation [1]. Because of complexity and precision of the required control on the transducer electrical state, design of the conditioning circuit for electrostatic transducers is the main bottleneck associated with e-VEH implementation. Moreover, high bias voltage is necessary to achieve strong mechanical coupling with an electrostatic transducer. This fact, combined with ultra low power requirement for the control circuitry, makes the design of the conditioning circuit very challenging. The low power requirement is related with the fact the energy harvesting is self-supplying, and the power available from microscale e-VEH is of order of few microwatts.

Several architectures of conditioning circuit exist [1, 2]. Our study focuses on the architecture based on a charge pump with an inductive flyback (Fig. 1a), [3, 4]. In this circuit, the

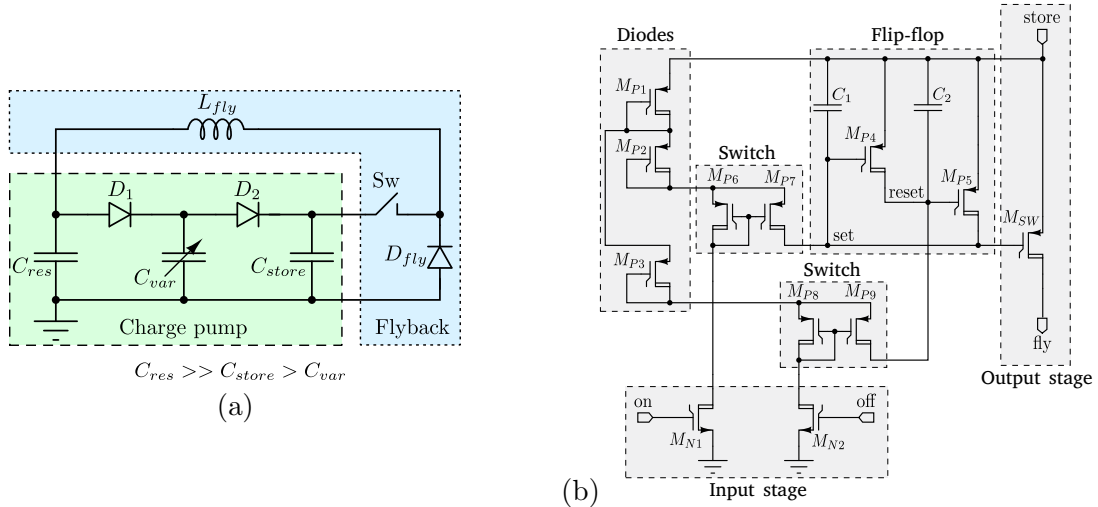

**Figure 1.** a) Energy harvesting system employing the auto-synchronous conditioning circuit initially proposed by B. Yen [4]; b) Proposed dynamic flip-flop level shifter driving the flyback switch  $M_{SW}$ , implemented in AMS035HV CMOS process.

synchronization of the charge flow is done internally thanks to the switching operation of the diodes  $D_1$  and  $D_2$ . The unique switch  $Sw$  requiring an external control operates rarely (once during tens of vibration cycles), and a synchronization with the mass vibrations is not needed. A significant advantage of this circuit over charge-constant [1] or voltage-constant [2] architectures is its suitability for operation with a resonator excited by broadband stochastic vibrations. This is experimentally proven in our work.

This paper presents the first integrated on silicon high-side switch  $Sw$  commuting high voltage (tens of volts) between the charge pump and the flyback in the conditioning circuit of Fig. 1a. The high-side  $Sw$  requires a level shifting driver, which allows an interface with a ground-referenced low voltage control signal. To comply with the speed and power consumption requirements, we designed a novel ultra-low power level shifter with zero static power consumption. This driver can be used to implement a smart control algorithm so to adapt the conditioning circuit operation to different application contexts [5]. The implemented switch driver was tested in the circuit of Fig. 1 with a real MEMS resonator presented in [6] excited with stochastic vibrations.

In contrast with previous integrated circuits for capacitive transducer conditioning [2, 7], we target the level of operation voltages which exceed the gate drive voltages of the used technology (e.g., for the AMS035HV process the gate voltage is 3.3 V, and the maximal drain-source voltage is 50 V). That is because the full potential of electrostatic transducers for energy conversion may only be explored with high-voltage operation.

## 2. System of e-VEH: structure and operation

This section describes the operation of the circuit of Fig. 1a [4]. The role of the charge pump is to pump the charges from a large capacitor  $C_{res}$  ( $\approx 1$ -10  $\mu\text{F}$ ) toward a smaller capacitor  $C_{store}$  ( $\approx 1$ -5 nF), making use of the variation of the transducer capacitance  $C_{var}$  ( $\approx 10$ -100 pF) which varies between its extrema values  $C_{max}$  and  $C_{min}$ . As the charge pump operates, the voltage across  $C_{store}$  increases, while  $V_{res}$  remains virtually constant (since  $C_{res} \gg C_{store}$ ). The energy for the  $C_{store}$  voltage elevation comes from the mechanical domain. The converted energy is stored in the voltage difference  $V_{store} - V_{res}$ . When  $V_{store}$  becomes significantly above  $V_{res}$  and approaches the saturation value  $V_{res}C_{max}/C_{min}$ , the charge pump starts to deliver less and less energy to  $C_{store}$ , and the energy conversion rate (the power) decreases.

To avoid this decrease of the converted power, the voltage difference between  $V_{store}$  and  $V_{res}$  must be reduced. This is achieved using a flyback return circuit with an inductive BUCK DC-DC converter topology. When the switch  $Sw$  is on, the charges from  $C_{store}$  are transferred to  $C_{res}$  via the inductor  $L_{fly}$  and freewheeling diode  $D_{fly}$ , hence putting the total (injected and converted) energy on  $C_{res}$ .

Our theoretical analysis identified the optimal  $V_{store}$  voltage range ( $V_1, V_2$ ), which corresponds to the maximal harvested power [8]. This result provides an indication of the optimal  $Sw$  switching sequence: the architecture implementing an optimal scenario is discussed in [5]. The bottleneck in implementation of this optimal operation is related to design of electrical interface between the control circuitry and the switch  $Sw$ . The main issue lies in the driving of the gate of a high-side MOS transistor with a low-voltage signal referenced to the ground. Therefore, an appropriate level shifter with very stringent power consumption specifications is needed. In the next section we present the designed architecture of a level shifter satisfying these requirements.

### 3. Switch driver architecture

The proposed level shifter is based on a zero static power topology based on an analog flip-flop [9], Fig. 1b. The flip-flop is composed of state-holding capacitors  $C_1, C_2$  and high-voltage (HV) PMOS pull-up transistors  $M_{P4}$  and  $M_{P5}$ , as shown in Fig. 1b. The input stage consists of two HV NMOS transistors drawing the current from  $V_{store}$  when the pulses *on* or *off* are high.

Initially both inputs *on* and *off* are low, and the state of the flip-flop is so that *set* node voltage equals  $V_{store}$ , and *reset* node voltage is  $V_{store} - 3V$ . When *on* goes high,  $C_1$  is charged to 3 V so that the *set* voltage become  $V_{store} - 3V$ ; this turns  $M_{P4}$  on, further pulling up *reset* to  $V_{store}$  and discharging  $C_2$ . Consequently,  $M_{P2}$  turns off. In that way the state of the flip-flop changes to the opposite. The reset of the flip-flop occurs similarly when *off* goes high.

MOS diodes  $M_{P1} - M_{P3}$  are used to limit the voltage drop to 3 V across the capacitors. The basic level shifter topology of [9] was supplemented with two switches  $M_{P6}, M_{P7}$  and  $M_{P8}, M_{P9}$ . They are used to electrically isolate the capacitors from discharge through the parasitic junction capacitances of the diodes, and thus to ensure stable states of the flip-flop during a long period without a need of refreshing.

The proposed level shifter and the high-side power switch have been fabricated in AMS035HV CMOS technology and successfully characterized. The measurement results have a good matching with simulations, as compared in Table 1.

**Table 1.** Level shifter and switch characteristics: measured versus simulated.

Characteristic	Measured	Simulated
Voltage range (V)	4–31	4–50
Switch ON-resistance ( $\Omega$ )	32–46	39
Consumed static power ( $nW$ ) (depending on $V_{store}$ voltage)	0.8–44.8	0.44–111.7
Dynamic energy consumed per <i>on/off</i> cycle ( $nJ$ ) (depending on $V_{store}$ voltage)	0.065–1.38	0.05–2.92
Switching speed ( $ns$ )	73	40
Max. duration of <i>on</i> -state without refresh ( $s$ )	5.8	11.2

### 4. Experiment

The goal of the experiment focuses on testing the operation of the e-VEH presented in (Fig. 1a), with use of the designed and fabricated switch/driver block. The energy conversion process is characterized by the charges accumulated on the reservoir capacitor  $C_{res}$ , which can be visualized by the voltage measurement on this capacitor.

The schematic of the test setup of the e-VEH system is given in Fig. 2. The circuit is initially energized with an external DC voltage source, which was connected for a short time to  $C_{res}$  and

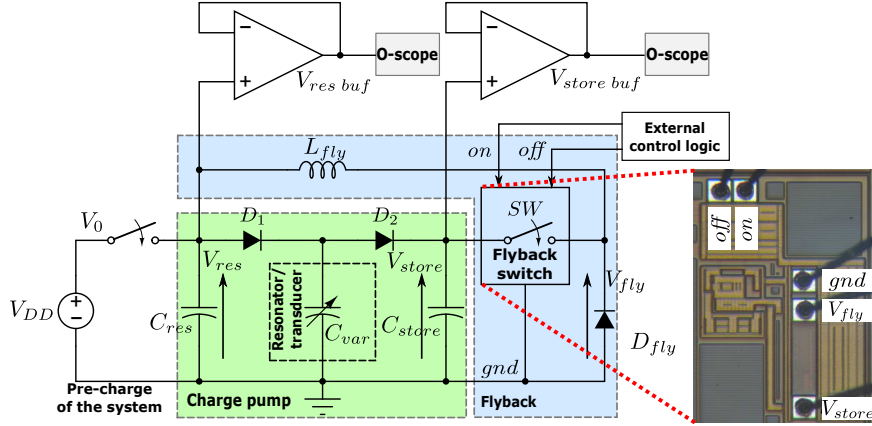

**Figure 2.** Schematic of a studied vibration energy harvester and micro-photograph of the implemented block.

so pre-charging it to a low initial voltage  $V_0 = 5.5V$ . The implemented flyback switch whose micro-photograph is illustrated in Fig. 2, is driven by the external control logic that generates periodically a sequence of *on* and *off* signals. A high input impedance and low offset operational amplifiers are used for the voltage probing across  $C_{res}$  and  $C_{store}$ .

The MEMS transducer/resonator device employed in the experiment was fabricated and fully characterized [6]. The resonance frequency of the resonator is 162 Hz. In large amplitude mode (1g of external vibration acceleration), it has half-power bandwidth of more than 30 % of the central frequency. The transducer capacitance varies between 45 pF and 74 pF.

When the external voltage source  $V_{DD}$  is disconnected from  $C_{res}$ , the e-VEH system becomes electrically autonomous, with the exception of the power source for the external control logic. The mechanical resonator is submitted to stochastic external vibrations whose energy is distributed in the frequency band (100-180) Hz.

## 5. Measurement results

The experiments described above were repeated with three sets of acceleration amplitude and bandwidth of vibrations. For the first, second and third experiments vibration parameters are 0.7 g rms @ 100-180 Hz, 0.8 g rms @ 110-170 Hz and 1 g rms @ 90-175 Hz, respectively. All three tests started with  $C_{res}$  pre-charged to 5.5 V. The flyback activation frequency was 5 Hz.

Fig. 3 presents the evolution in time of  $C_{res}$  voltage (upper plot) and energy (bottom plot). After 3000-4000 seconds of autonomous system operation, the voltage across  $C_{res}$  rises up to 15-20 volts. Sudden drops of the  $V_{res}$  voltage can be observed. This occurs as  $V_{res}$  voltage reaches a level at which a dynamic pull-in occurs. The  $V_{res}$  drops are due to a short circuit between the plates of the variable capacitor  $C_{var}$ : when it happens,  $C_{res}$  discharges very fast through the diode  $D_1$  until the voltage at which the pull-in effect disappears. This is an undesirable effect related with the physics of the MEMS device presented in [6]. The voltage of dynamic pull-in depends on the acceleration amplitude of the external vibrations: at lower acceleration amplitudes, the dynamic pull-in voltage is higher. As a result, the higher levels of  $V_{res}$  can be achieved at lower acceleration amplitude, as shown by the measurement. The short circuit "emulates" a load consuming the energy of the storage capacitor, and it can be seen that the energy production on  $C_{res}$  is stable on the observed time interval (4000-7000s)

During three experiments the maximum achievable  $V_{res}$  voltage was 21 V, 21.5 V and 17 V, this corresponds to the energy on  $C_{res}$  of 220  $\mu J$ , 230  $\mu J$  and 145  $\mu J$ , respectively (to be compared with the initial energy of 15  $\mu J$  corresponding to  $V_{res} = V_0$ ). The maximal average energy conversion rate (power) measured as the slope of the straight segments of the energy curve is

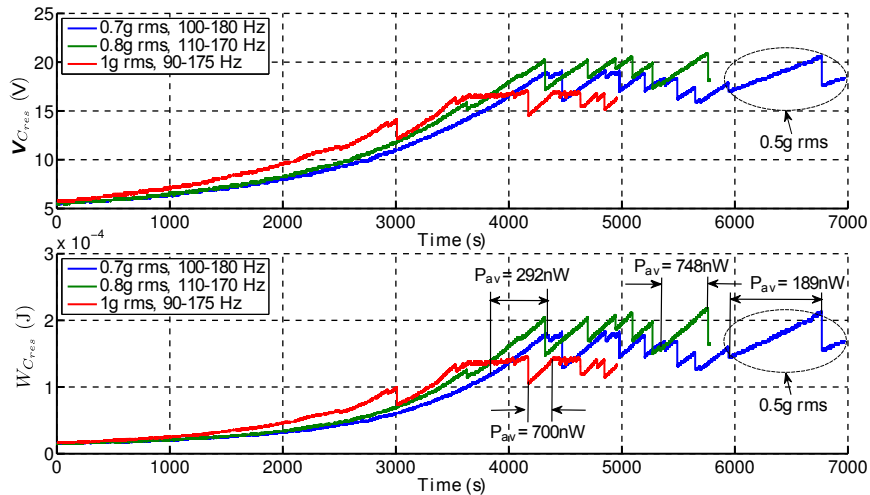

**Figure 3.** Evolution of the state of the studied system in autonomous mode submitted to stochastic external vibrations, with three different stimuli. Upper plot: the voltage across the reservoir capacitor  $C_{res} = 1\mu\text{F}$ , lower plot: the energy of  $C_{res}$ .

between 190 nW and 750 nW (cf. Fig. 3, lower plot). These figures give the net energy and power available for the load supply, accounting for the consumption of the flyback switch, losses in reactive elements and in the diodes.

## 6. Conclusions

We presented an investigation in the design of e-VEH system based on the auto-synchronous architecture. The work addressed a novel integrated ultra-low power high-voltage switch employed in the conditioning circuit. With the use of the implemented switch we tested the autonomous operation of the MEMS capacitive energy harvester excited with stochastic vibrations in a large bandwidth 100-180 Hz. Initially biased to 5.5 V with 15  $\mu\text{J}$ , the system increased its voltage up to 21.5 V with the accumulated energy 230  $\mu\text{J}$ . The maximal measured net power is 748 nW without considering supply of the generator of switching events. The design of a latter block is a subject of ongoing work.

## References

- [1] S. Meninger, J. Mur-Miranda, R. Amirtharajah, A. Chandrakasan, and J. Lang, "Vibration-to-electric energy conversion," *IEEE Trans. on VLSI Systems*, vol. 9, no. 1, pp. 64–76, Feb. 2001.
- [2] E. O. Torres and G. A. Rincón-Mora, "Electrostatic energy-harvesting and battery-charging CMOS system prototype," *IEEE Trans. on Circuits and Systems I: Regular Papers*, vol. 56, no. 9, pp. 1938–1948, 2009.
- [3] S. Roundy, P. K. Wright, and J. Rabaey, "A study of low level vibrations as a power source for wireless sensor nodes," *Computer Communications*, vol. 26, no. 11, pp. 1131–1144, Jul. 2003.
- [4] B. C. Yen and J. H. Lang, "A Variable-Capacitance Vibration-to-Electric Energy Harvester," *IEEE Transaction on Circuits and Systems-I: Regular papers IEEE*, vol. 53, no. 2, pp. 288–295, 2006.
- [5] A. Dudka, D. Galayko, and P. Basset, "Design of integrated smart adaptive conditioning circuit for capacitive vibration energy harvester," in *Workshop of Energy and Wireless Sensors*, Besançon, France, 2012.
- [6] R. Guillemet, P. Basset, D. Galayko, F. Cottone, F. Marty, and T. Bourouina, "Wideband MEMS electrostatic vibration energy harvesters based on gap-closing interdigitated combs with a trapezoidal cross section," in *Micro Electro Mechanical Systems, 2013 IEEE 26th International Conference on*, 2013, pp. 817–820.
- [7] A. Kempitiya, D.-A. Borca-Tasciuc, and M. M. Hella, "Low-Power Interface IC for Triplate Electrostatic Energy Converters," *IEEE Transactions on Power Electronics*, vol. 28, no. 2, pp. 609–614, Feb. 2013.
- [8] D. Galayko, R. Pizarro, P. Basset, A. M. Paracha, and G. Amendola, "AMS modeling of controlled switch for design optimization of capacitive vibration energy harvester," *2007 IEEE International Behavioral Modeling and Simulation Workshop*, pp. 115–120, Sep. 2007.
- [9] P. Basset, "Conception, réalisation et test d'un micro système de transport alimenté à distance," Ph.D. dissertation, Univesité de Lille1, 2003.