



<b>Title</b>	Challenges and solutions to model-scale testing for composite deep foundations and existing foundation enhancement
<b>Authors(s)</b>	Laefer, Debra F., Manke, Jonathan P., Tucker, Jason E., Batten, Yuri
<b>Publication date</b>	2007
<b>Publication information</b>	Laefer, Debra F., Jonathan P. Manke, Jason E. Tucker, and Yuri Batten. "Challenges and Solutions to Model-Scale Testing for Composite Deep Foundations and Existing Foundation Enhancement." American Society of Civil Engineering (ASCE), 2007. <a href="https://doi.org/10.1061/40902(221)18">https://doi.org/10.1061/40902(221)18</a> .
<b>Conference details</b>	Geo-Denver 2007: New Peaks in Geotechnics, February 18–21, 2007, Denver, Colorado
<b>Series</b>	Critical Infrastructure Group
<b>Publisher</b>	American Society of Civil Engineering (ASCE)
<b>Item record/more information</b>	<a href="http://hdl.handle.net/10197/2139">http://hdl.handle.net/10197/2139</a>
<b>Publisher's version (DOI)</b>	10.1061/40902(221)18

Downloaded 2026-05-02 00:29:49

The UCD community has made this article openly available. Please share how this access benefits you. Your story matters! (@ucd\_oa)



© Some rights reserved. For more information

## **Challenges and Solutions to Model-Scale Testing for Composite Deep Foundations for Existing Foundation Enhancement**

Debra F. Laefer,<sup>1</sup> Jonathan P. Manke,<sup>2</sup> Jason E. Tucker,<sup>3</sup> and Yuri Batten<sup>4</sup>

<sup>1</sup>Lecturer, Civil Engineering, University College Dublin, Earlsfort Terrace, Dublin 2, Ireland; PH 353-1-716-7276; FAX 353-1-716-7399; e-mail: debra.laefer@ucd.ie

<sup>2</sup>Field Engineer, Terracon, Charlotte, North Carolina

<sup>3</sup>Graduate student, Department of Civil Engineering, North Carolina State University

<sup>4</sup>Civil Engineer, United States Army

### ***Abstract***

Laboratory testing for foundation design offers advantages over field-testing, especially, where existing installations preclude easy accessibility. Advantages include a homogeneous soil, ability to place instrumentation throughout the soil mass, and capacity to bring the system to failure, as well as control over the failure mechanism. Repeatability is also achievable. Laboratory work, however, has its own challenges. For model-scale work, a main impediment is scaling: strength, dimensions, and boundary conditions hinder accurate modeling of the soil and brings a difficulty in representing scaled foundations. This paper describes the construction-oriented solutions pioneered for meeting the geometric requirements of  $\frac{1}{8}$ <sup>th</sup> scaled laboratory testing of composite deep foundations for existing foundation enhancement, including drilled shafts, helical piers, and grouting. Results of the testing program are included as verification of the usefulness of the techniques.

**Keywords:** Foundations, Reuse, Piles, Ground Improvement, Ground Reinforcement, Helical Piers, Grouting, Laboratory Testing, Drilled Shafts

### ***Introduction***

When replicating construction elements and processes at a small scale, decisions must be made as to which materials, installation processes, and parameters are crucial to replicate and which have minimal impact on system outcomes. Limitations of time, labor, cost, and material may also pose restrictions. A successful small-scale model offers inexpensive opportunities to conduct sensitivity studies on the impact of specific parameters. Some full-scale control testing is still, however, required to verify the model results.

For Geotechnical Engineering, there are many aspects of model-scale testing that are more advantageous than field-testing, including complete control of the soil profile (e.g. soil type, gradation, moisture content, and homogeneity), ability to place instrumen-

tation in the soil mass, opportunity to bring the system to failure and select the failure mechanism, and being entirely repeatable. Yet, laboratory work is not a panacea. Significant challenges in terms of scaling both for material properties and constructability exist. Scaling reflects both geometric and behavioral requirements. This paper presents a set of geometrical and installation related solutions for the testing of a deep foundation system combined with grouted helical piers that are designed to interact with an existing foundation for the purpose of rehabilitation and capacity enhancement. Challenges include constructability and placement, as well as manufacturing. The proposed set of solutions is for a 1/8<sup>th</sup> scale model and may also be adaptable to centrifuge testing.

## **Background**

Although design of driven piles and drilled shafts is largely established, (Chellis, 1961, Tomlinson, 1994, O'Neill et al., 1999), significant research continues. Traditionally, pile groups have been categorized as free-standing (pile cap is considered not in contact with the ground) or piled footings (pile cap contact and load transfer is assumed) (Poulos et al., 1980, Long, 1993). These studies have largely focused on driven piles or by backfilling around the piles (Mayne et al., 1994), with the majority of research, at any scale, performed on free-standing pile groups. Of the previous studies involving small-scale, axially loaded piled footings in sand, Akinmusuru (1980) tested the capacity increase of a pile group, when the pile cap contacted the ground, and Kishida and Meyerhoff (1965) evaluated the bearing capacity of both free-standing pile groups and piled footings including both concentric and eccentric loading. Mayne et al. (1994) modeled the lateral capacity of individual drilled shafts but in clay, rather than sand. This paper presents parts of a small-scale experimental programs investigating pile groups with ground improvement/ground reinforcement (GIGR) techniques.

## **Scaling**

When working at less than full-scale, the main issue is stress-strain compatibility. This complex topic can be simply described. Since soil strength and stiffness are considered to be largely linear with depth, a scaled experiment has less strong and less stiff soil. Thus, the loads on the soil must be reduced. Consequently, for any structural elements to respond at the low stress levels, as if they are experiencing real-world stress levels, their strengths and stiffnesses, as well as their geometries must be adequately reduced. (See Altaee et al., 1994, Laefer 2001, Ko et al., 1984, Yan et. al., 1989 and Zelikson, 1969).

## ***Larger research program***

Solutions herein presented were pioneered for a medium-sized testing pit (Fig. 1), to investigate the possibility of using super-position as a design methodology for complex and composite GIGR systems used in combination with existing deep foundations, as fully documented in Manke 2004 and Laefer and Manke 2006 (Table 1 and Fig. 2).

Tests were conducted at 1/8<sup>th</sup> scale to permit multiple sample testing, without incurring boundary condition problems. The prototype pile foundation was designed based on ADSC (1999) specifications. Prototype foundations consisted of 4, 18" diameter, 12' long, cast-in-place piles in a 2 x 2 configuration, with 54" center-to-center spacing. A 10"

diameter reinforcing cage consisting of 6, #8 longitudinal bars with #4 spiral reinforcing bar at 6" spacing was placed in each pile, with a 4" concrete cover due to casing removal. Extreme care was taken in placement of oven dried, uniform sand, via a sieve based pluviation mechanism, which was checked via a nuclear density gauge (Manke 2004).

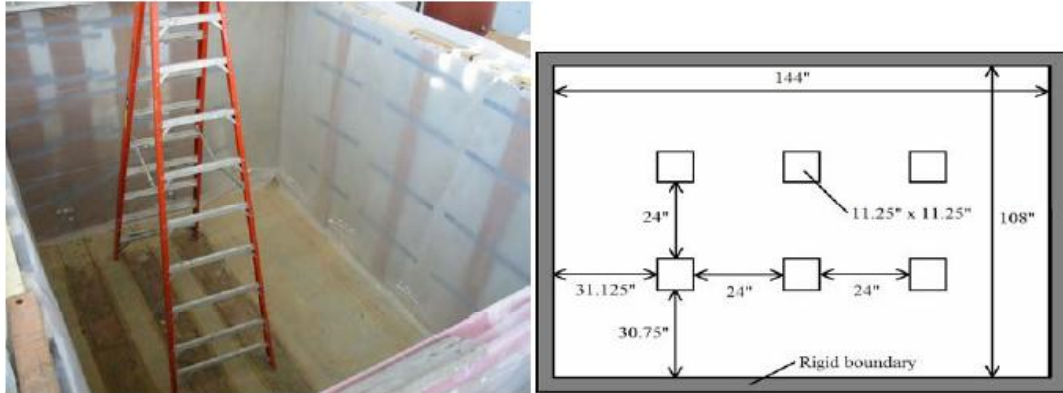

Fig. 1. Testing pit (left) and schematic testing arrangement (right)

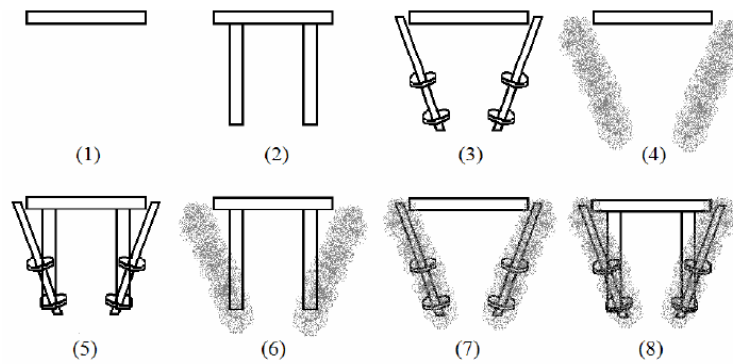

Fig. 2. Various testing arrangements

Table 1. Overview of testing program for both axial and lateral tests

Elements	Component Tests				Composite Tests			
	1	2	3	4	5	6	7	8
Cap (C)	X	X	X	X	X	X	X	X
Piles (P)		X			X	X		X
Helical Piers (R)			X		X		X	X
Grout (G)				X		X	X	X

### Specific Challenges

Use of full-scale construction methods becomes increasingly difficult as the model's size decreases. Thus, alternative procedures are often needed. Also, full-scale mechanical apparatuses contain many intricate parts that are already small in scale. Attempting to replicate these mechanical features at smaller scales can be expensive, if not impossible, because of the extensive and delicate machining required. Side-stepping the issue of the need for diminished material strength, each part needs to be scaled down in order to produce a correct model. To begin to solve the problem, models were made that

were smaller than the prototype but larger than the final target product. This approach allowed the early identification of many of the obstacles that may be encountered at a small scale. By working at a “relaxed” scale, one can optimize design and construction of key features of the prototype without having to worry about the preciseness of working at an extremely small scale. “Relaxed” scale building provides insight as to potential failure mechanisms and weak connection points. Additionally, the process helps to evaluate material viability at a small scale. This technique speeds development, because early apparatuses can more easily be produced.

## Main Challenges

Consistent geometry, installation angle, and installation processes were critical. The greatest scaled constructability challenges related to helical pier construction, driving, and grouting, particularly in being able to grout while driving the piers. Some of the solutions pioneered here have already been adopted by others (Bien et al. 2006).

## Helical Piers

Thirty-two production piers were constructed to match prototype helical piers from technical documents provided by Precision Pier USA, Inc. (fig. 3) [Roger 2002]. The piers consisted of a 4” diameter, round tube shaft, and a pair of 16” diameter, 3” pitch helices spaced at 48” apart. The shaft’s base was cut at 45°, and the grout hole was located approximately 5” from the pier tip. The prototype was scaled down to a 0.5” outer diameter, 0.37” inner diameter, 34” long, round tube shaft, with a pair of 2” diameter, 3/8” pitch helices spaced 6” apart. The shaft base was cut at 45°, and a 1/8” diameter grout hole was located at approximately 5/8” from the pier tip. Critical was helices formation (fig. 4).

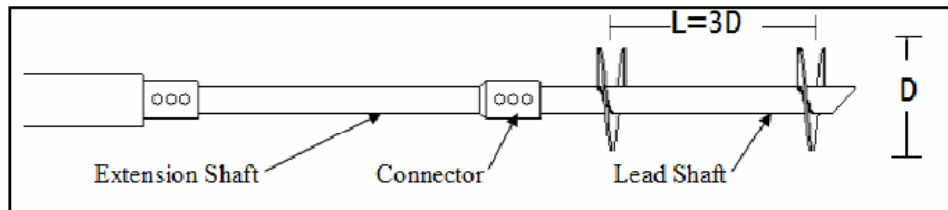

Fig. 3. Prototype helical pier layout (Rogers 2002)



Fig. 4. (a) Helix mold



(b) Mold in press



(c) Final product

The helices were modeled using 2” diameter fender washers with 0.5” center holes. The washers were cut and formed into a helical shape using a specially made press

and mold. The press consisted of several bolts set to gradually decreasing heights, until a 0.375" pitch was obtained. Each washer was placed into the mold and pressed. After pressing, the surfaces of both washers and the round tube were scored to increase the effectiveness of the two-part bonding adhesive, JB Weld. Finally, both tube ends were filled with epoxy to prevent the unintended expulsion of grout and unwanted introduction of sand into the tube as the pier advanced; helices were attached such that the splits were offset 180°.

The helices were modeled using 2" diameter fender washers with 0.5" center holes. The washers were cut and formed into a helical shape using a specially made press and mold. The press consisted of several bolts set to gradually decreasing heights, until a 0.375" pitch was obtained. Each washer was placed into the mold and pressed. After pressing, the surfaces of both washers and the round tube were scored to increase the effectiveness of the two-part bonding adhesive, JB Weld. Finally, both tube ends were filled with epoxy to prevent the unintended expulsion of grout and unwanted introduction of sand into the tube as the pier advanced; helices were attached such that the splits were offset 180°.

### Grouting

Grout was placed in a pressurized cylinder 2' tall and 1' in diameter, with a 5/8" grout exit nozzle 1" from the bottom of the cylinder (Fig. 5). The top had a pressure release valve and an air intake and was regulated by a gage atop the cylinder.

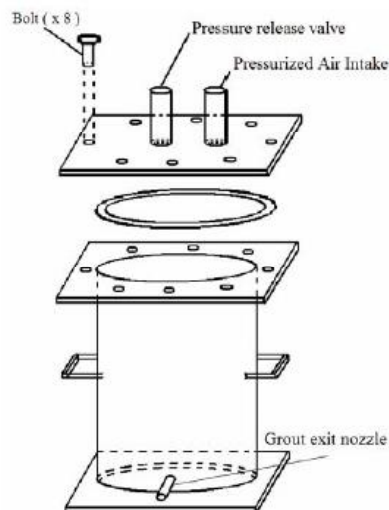

Fig. 5. Pressurized grout cylinder

### Installation Rig

Grouted helical pier installation required both a consistent installation rate and simultaneous grout injection. The helical pier installation rate depended on the pitch of the helices and the pier rotation rate. To achieve the consistent installation rate, a single speed motor (9 rpm) was mounted to a wooden frame to create a sliding jig (Figs 6-7). The pier was attached to the motor using a coupler, and the jig was then placed on an angled platform such that the pier could rotate itself into the ground. The platform was an-

gled at 79° and was leveled before each pier was installed to ensure a consistent installation angle.

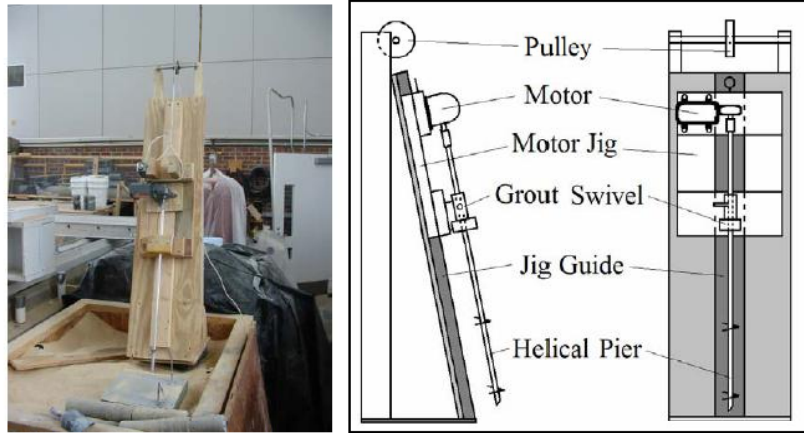

Fig. 6. Jig mounted on platform Fig. 7. Jig and platform schematic

Since the motor was attached to the pier end (Fig. 8), the grout has to be injected through a slot cut into the side of the pier (Fig. 9). Thus, the grouting system had to allow for the simultaneous grout injection and pier rotation via a grout swivel.



Fig. 8 Pier-motor coupler



Fig. 9 Slot for grout injection

A grout swivel allows the helical pier to rotate while injecting grout (Fig. 10 and 11). The pier was placed through the swivel and attached to the motor such that the pier's slot was aligned with the swivel's grout reservoir (Fig. 12). When the reservoir was full, the grout was then forced into the slot on the helical pier and out the base of the pier. The swivel was attached to the pier using a rubber hose and hose clamps (Fig. 13).



Fig. 10. Grout swivel exploded view



Fig. 11. Grout swivel



Fig. 12. Grout reservoir



Fig. 13. Grout-pier attachment

Once the grout was in the pressurized cylinder and the helical pier and grout swivel were mounted on the motor jig, the cylinder was attached to the swivel via a grouting tube and the jig was placed on the angled platform. When the helical pier was to be backed out for installation of the grouted columns, a weight equal to the weight of the jig was hung from a rope that passed over a pulley and attached to the back of the jig.

### Grout and pier installation

Grouting was performed for two foundations: those with grouted helical piers and those with only grouted columns. The pier was placed so that it consistently entered the ground at the center of the pile cap side,  $79^\circ$  from horizontal (Fig. 14), such that the helical pier reaches the cast-in-place piles' base. Grout was mixed and placed in a pressurized cylinder and vibrated to remove trapped air. The cylinder's exit grout nozzle was then attached to the helical pier via a grout swivel, and the cylinder was pressurized until grout flowed into the swivel and out the pier's bottom. At which point, the motor was turned on and allowed to pull the pier into the ground. As the pier advanced, pressure was increased 1 psi per inch, until the pier had reached target depth. If the foundation contained a grouted pier, then the pier was detached and left in place. If not, the pier was removed after grouting by reversing the motor and applying a weight to the back of the motor equivalent to the jig to help the pier rotate itself out of the ground. While the pier was being removed, grout was pumped into the ground to fill any voids left by the pier. A preproduction program was conducted to determine grouting pressures (Laefer et al. 2005).



Fig. 14. Grout tube connected to grout swivel and subsequent installation

## Results

As a displacement based failure criteria was chosen, each test was executed to a specified displacement. Typically, full-scale piles require ¼” to ½” displacement to fully mobilize the side friction and approximately 1/10<sup>th</sup> the pile diameter to fully mobilize the end bearing (Poulos et al. 1980). At 1/8<sup>th</sup> scale, these values would be from 1/32” to 1/16”.

The scaled values were felt to be too small to fully mobilize capacity. An initial load test displayed material failure at ½” of displacement. As material failure was not the goal, a ¼” displacement was chosen as the failure criteria for both the axial and lateral tests. The results of the subsequent load-deflection curves were used to establish any systemic failure.

Prior to testing, the load-deflection performance was predicted (Table 2). The load versus displacement curves for each of the 8 axial tests are shown in Fig. 15.

Table 2. Predicted and tested axial test performance

Test Label*	Tested Ranking	Predicted ranking	Load (lbs) at 0.1” displacement	Load (lbs) at 0.25” displacement
Axial Cap Pile Pier Grout (ACPRG)–[8]	1	1	2,063	3,525
Axial Cap Pile Pier (ACPR)–[5]	2	3	2,030	3,400
Axial Cap Pile Grout (ACPG)–[6]	3	2	2,025	3,400
Axial Cap Pile (ACP)–[2]	4	4	1,685	3,120
Axial Cap Pier (ACR)–[3]	5	7	1,450	2,710
Axial Cap Pier Grout (ACRG)–[7]	6	5	1,325	2,515
Axial Cap Grout (ACG)–[3]	7	6	1,260	2,390
Axial Cap (AC)–[1]	8	8	1,145	2,260

\*Values in brackets represent testing arrangement shown in figure 1.

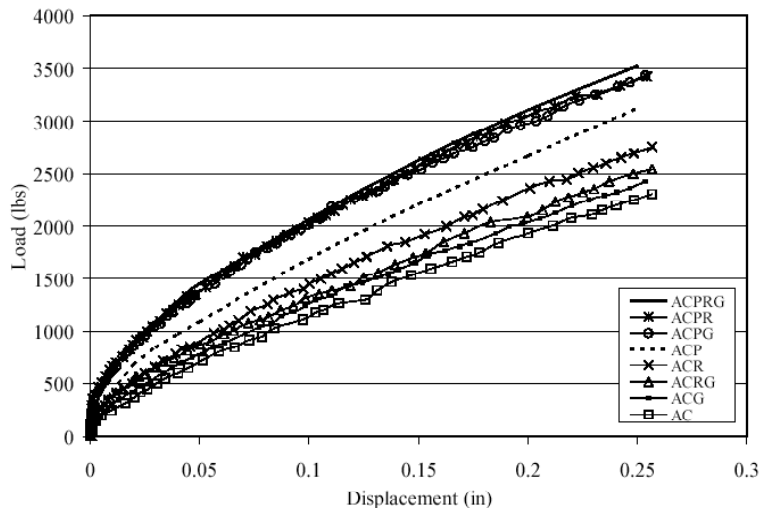

Fig. 15. All axial tests' load-deflection comparison

As predicted, all cap only foundations performed worse than those with piles, and those without screw piles or grouting performed worse than those with them (Table 2). Results were generally as expected. The main discrepancy was the lower capacity of the grouted screw piles in comparison to the screw piles without grout and the better performance of the screw piles compared to that just with grout. The screw piles were able to

either better transfer the load or were able to densify the soil. With the piles, the difference was within 1% at the lower displacement and no change at the higher displacement. Without the piles, they were within 10% of each other at both displacement levels. The slightly superior performance of screw piles over the grouted helical piers was unexpected and may be a function of the extreme soil dryness and uniformity. Typical field installations for grouted, screw piles are in non-uniform soils with some water content, such that as the screw piles is installed, the helix carved path is able to remain open such that the grout can fill it. The dry laboratory sand did not allow the helix carved path to stay open, which may have caused a small amount of loosening of soil around the piles. This looser soil configuration would result in a decreased soil-pile interface friction angle and, ultimately, a decrease in pile capacity. Figure 16 shows the percent improvement of each foundation as compared to the cap only foundation. The results indicate that a form of superposition may be appropriate to estimate the improvement of complex GIGR systems. This concept is discussed in further detail by Laefer and Manke (2006).

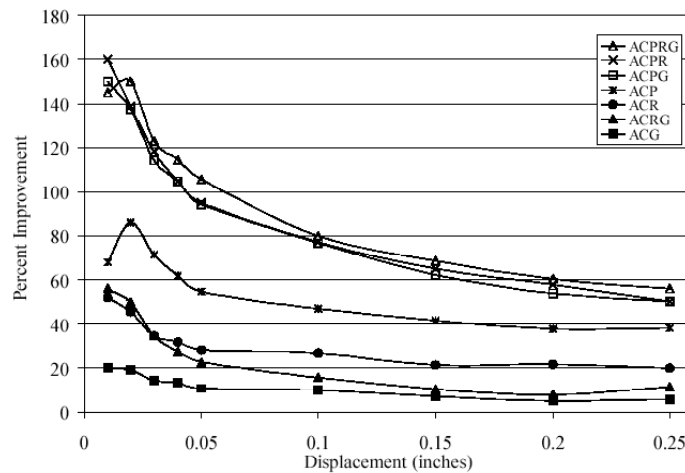

Fig. 16. Percent improvement of axial load for increasing displacements

## Conclusions

Due to advantages in control and repeatability, laboratory testing is highly beneficial for advancing Geotechnical Engineering but is not free of challenges. Model representations of field conditions, installation, equipment, and final products must be dimensioned. Yet, accurate and precise experimentation with models can be achieved through correct scaling of geometric and physical properties associated with less than full-scale prototypes and their boundary conditions associated with the environments in which they are tested. This paper represents the preliminary geometrical work for  $\frac{1}{8}$ <sup>th</sup> scale laboratory investigations of composite foundations for deep foundation rehabilitation.

## Acknowledgments

Support for this research was in part provided by the University College Dublin's Institute for Sustainable Development.

## References

- Association for Drilled Shaft Contractors (ADSC) (1999). *ADSC standards and specifications*, Dallas, TX.
- Akinmusuru, J.O. (1980). "Interaction of piles and cap in piled footings", *J. Geotechnical Eng.* 106(11) 1263-1268.
- Altaee, A. & Fellenius, B.H. (1994). "Physical modeling in sand", *Can. Geotechnical J.* No. 31, 420-431.
- Bian, Y., Hutchinson, T.C., Wilson, D. and Laefer, D.F. (2006, in press). "Grouted helical piers for use in foundation rehabilitation: centrifuge testing", *Int. conf. re-use of foundations for urban sites*. 17 Oct. BRE, Watford, UK.
- Chellis, R.D. (1961). *Pile foundations*. (2<sup>nd</sup> ed.). NY: McGraw-Hill Company, Inc.
- Kishida, H. and Meyerhof, G.G. (1965). "Bearing capacity of pile groups under eccentric loads in sand", *Proc. 6th int. conf. on soil mechanics and foundation engineering*, Toronto, Vol. 2, pp. 270-274.
- Ko, H.Y., Atkinson, R.H., Goble, G.G., & Ealy, C.D. (1984). "Centrifugal modeling of pile foundations." J.R. Meyer (Ed.), *Analysis and design of pile foundations*. Reston, VA: ASCE, 21-40.
- Laefer, D.F. (2001). *Prediction and assessment of ground movement and building damage induced by adjacent excavation*. PhD Thesis UIUC. pp. 903.
- Laefer, D.F. and Manke, J.P. (2006, in press). "Small-scaled testing of rehabilitated pile groups." *Int. conf. re-use of foundations for urban sites*. Oct. 17. BRE, Watford, UK.
- Laefer, D.F., Menninger, N., and Hernandez, W. (2005). "Grouting Patterns and Possibilities with Helical Piers", *Underground construction in urban environments: a specialty seminar ASCE May 11 and 12, 2005*, New York City, Session 5, pp. 1-10.
- Long, P.D. (1993). "Footings with settlement-reducing piles in non-cohesive soil", *Swedish Geotechnical Institute, Report No. 43*. Linkoping, Sweden: SGI.
- Manke, J.P. (2004). *Assessment of superposition as a design framework for the combined effects of soil improvement and foundation remediation*. MS Thesis NCSU.
- Mayne, P.W., Kulhawy, F.H., and Trautmann, C.H. (1994). "Laboratory modeling of laterally-loaded drilled shafts in clay", *J. Geotechnical Engineering*. 121(12) 827-835.
- O'Neill, M.W. and Reese, L.C. (1999). *Drilled shafts: construction procedures and design methods*. Dallas, TX: ADSC.
- Poulos, H.G., and Davis, E.H. (1980). *Pile foundation analysis and design*. NY: John Wiley and Sons.
- Rogers, W. (2002). *Manual of screw pile foundations* (5<sup>th</sup> ed.). TX: Energy Structures Inc.
- Tomlinson, M.J. (1994). *Pile design and construction practice*. London: E&FN Spon.
- Yan, L., & Byrne, P.M. (1989). "Application of hydraulic gradient similitude method to small-scale footing tests on sand." *Can. Geotechnical J.* 26(2) 246-259.
- Zelikson, A. (1969). "Geotechnical models using the hydraulic gradient similarity method." *Geotechnique*. 19(4) 495-508.