



Title	A finite element technique for the investigation of the shape development of planar cracks with initially irregular profiles
Authors(s)	Chipalo, M. I., Gilchrist, M. D., Smith, R. A.
Publication date	1990-01
Publication information	Chipalo, M. I., M. D. Gilchrist, and R. A. Smith. "A Finite Element Technique for the Investigation of the Shape Development of Planar Cracks with Initially Irregular Profiles." Elsevier, January 1990. https://doi.org/10.1016/0020-7403(90)90020-J .
Publisher	Elsevier
Item record/more information	http://hdl.handle.net/10197/5918
Publisher's statement	This is the author's version of a work that was accepted for publication in International Journal of Mechanical Sciences. Changes resulting from the publishing process, such as peer review, editing, corrections, structural formatting, and other quality control mechanisms may not be reflected in this document. Changes may have been made to this work since it was submitted for publication. A definitive version was subsequently published in International Journal of Mechanical Sciences (32, 3, (1990)) DOI: http://dx.doi.org/10.1016/0020-7403(90)90020-J
Publisher's version (DOI)	10.1016/0020-7403(90)90020-J

Downloaded 2026-05-01 23:37:48

The UCD community has made this article openly available. Please share how this access benefits you. Your story matters! (@ucd_oa)



© Some rights reserved. For more information

A FINITE ELEMENT TECHNIQUE FOR THE INVESTIGATION OF THE SHAPE DEVELOPMENT OF PLANAR CRACKS WITH INITIALLY IRREGULAR PROFILES

M. I. CHIPALO, M. D. GILCHRIST and R. A. SMITH[†]

Department of Mechanical and Process Engineering, Sheffield University, Mappin Street, Sheffield S1 3JD, U.K.

Abstract—The introduction to this paper describes a general finite element model used to calculate opening mode stress intensity factors (K_I) along the front of an irregular planar crack. Crack advance is calculated as a function of K_I and a new profile is thus defined. Automatic reconfiguration of the finite element mesh enables the crack development to be followed. The use of this technique to investigate various problems of practical interest is then described. These examples include the effect of constrained and unconstrained corners on developing cracks, the interaction of two adjacent thumbnail cracks, the breakout of an internally initiated crack and the effect of a surface crack in a leak before break situation.

NOTATION

K_I	opening mode stress intensity factor
G	modulus of rigidity
ν	Poisson's ratio
C, m	material constants in Paris law
r, v	distance and out of plane displacement from crack front to node (Fig. 1)
da/dN	crack front growth rate
ΔK	stress intensity factor range
a_0, c_0, h_0, t_s, T	dimensions defining geometry

INTRODUCTION

This work contributes to the analysis of the stability and growth of irregular planar defects normal to the remote applied stress by utilizing the concepts of linear elastic fracture mechanics. K_I , the opening mode stress intensity factor is used to characterize such problems. A general finite element model used to calculate K_I along the crack front is described. Local crack growth is calculated as a function of K_I along the crack front and a new profile is consequently defined. The finite element mesh is automatically reconfigured to the new profile thus allowing the model to follow the development of the crack shape by repeated iterations.

SOLUTION PROCEDURE

At any point on the crack front, a section plane can be defined to exist orthogonal to the plane of the crack and normal to the tangent to the crack front at the point, as shown in Fig. 1. The displacements of the crack surface are calculated by a finite element analysis and subsequently used in the near crack tip stress field equations to obtain the local K_I value. This procedure is repeated for other points on the crack front and a local normal increment of growth is calculated for each of the points chosen. For the work described here the Paris growth law equation is used to relate local K_I to crack advance. Figure 1 details how the advance of these points establishes a new location of the crack front as a result of fatigue crack growth. Redefinition of the finite element mesh to assume the position of the new crack front, and subsequent iteration of the analysis procedure permits the actual progression of the crack front growth to be followed [1]. While this investigation examines fatigue crack growth it is equally feasible to analyse any other process that is dependent on a local stress/strain field parameter calculated by the finite element method.

[†] Author to whom correspondence should be addressed.

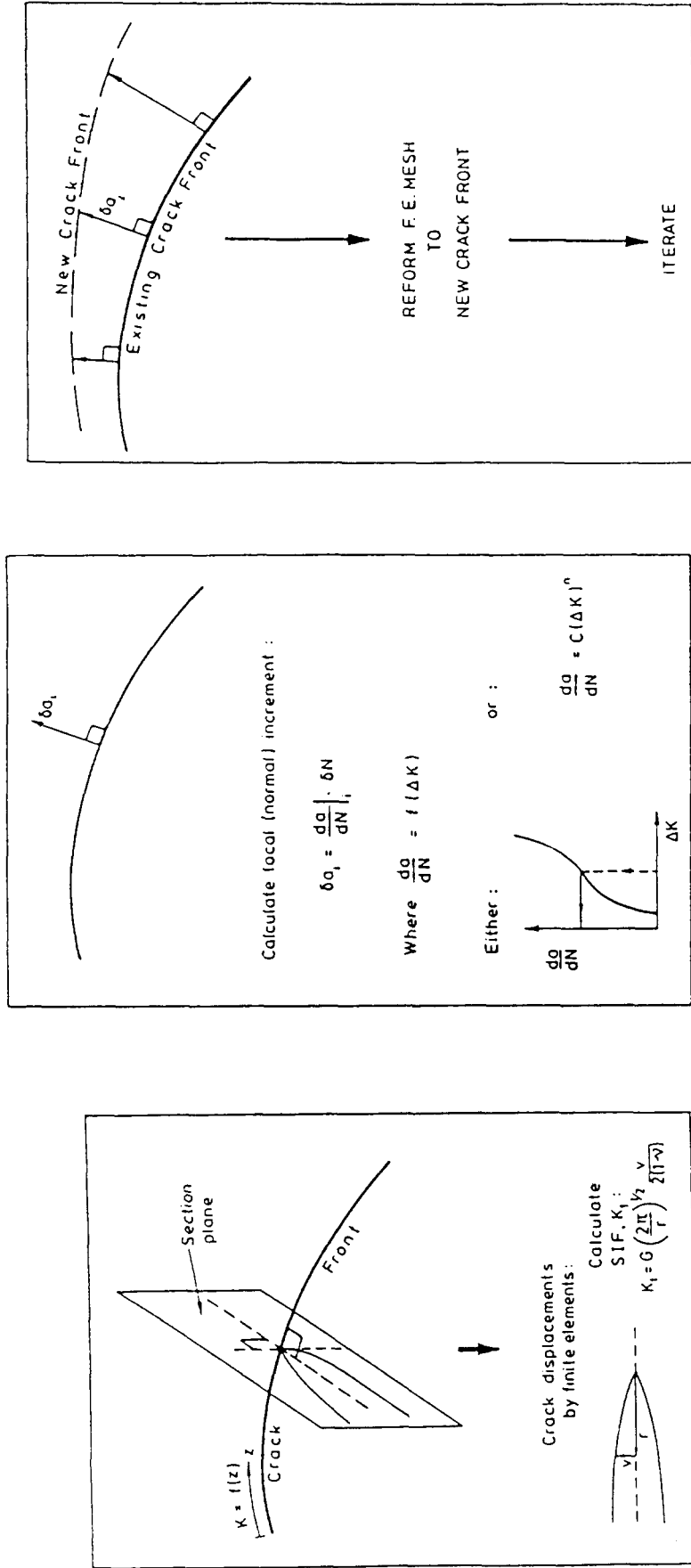

FIG. 1. Modelling the growth of crack fronts with varying stress intensity factors, K_I , by finite elements and linear elastic fracture mechanics.

The advantages of this particular analysis are two-fold; it facilitates the automatic remeshing of the finite element model from one crack front position to the next and it considerably reduces the complexity of the finite element mesh thereby allowing detailed examination of the volume around the crack.

The schematic of a typical problem is shown in Fig. 2. Two blocks are used for the analysis; the larger, block 1, contains the loading surface and the smaller, block 2, contains a definition of the crack shape on its base, face B. The bulk of the uncracked material is represented by block 1 and remains unchanged throughout the analysis. Block 2, modelled with a finer mesh, follows the growth of the crack and is reassembled after each growth step. Faces B and A_1 in this instance define two planes of symmetry while faces A_1 and A_2 are used to apply loading and/or boundary conditions (planes of symmetry or free surfaces etc.) appropriate to the problem under consideration.

The base of block 2 contains the cracked surface. This plane is defined by the 2-D mesh of Fig. 3 by means of MENTAT, the preprocessing program associated with the MARC finite element solver. The cracked surface is represented as shaded for clarity and the 2-D elements are eight-noded, quadrilateral and isoparametric. However the elements abutting the crack front have their midside nodes located at the quarter points closest to the front, following the work by Barsoum [2], which avoids the need for using special crack tip elements.

A purpose-written program expands the 2-D mesh of Fig. 3 into the 3-D mesh of block 2 [1]. Away from the crack front the elements are 20-noded isoparametric bricks. 2-D elements abutting the crack front are expanded into four 20-noded bricks, two of which are degenerated into 15-noded wedges, as shown in Fig. 4. The midside nodes of elements surrounding the crack tip are automatically set at the quarter points.

A further purpose-written program joins blocks 1 and 2 together and ensures complete nodal continuity across the interface by interpolation. Coincident nodes on the two surfaces are merged whilst those nodes which are not, are tied to the interface by means of constraint equations [1]. While constraint equations are a source of possible error this is considered to be negligible especially when the interface is relatively distant from the crack front and separated by at least two layers of elements. This fact is evidenced by the subsequent K_I calculations which agree well with accepted solutions.

It is important to orientate elements so that their edges intersect the crack front orthogonally in order that the true magnitude of the stress intensity factor is calculated for the corner point nodes on the crack tip. This is not possible where the crack makes a sharp change of direction or where the crack tip approaches a free surface. However it was found

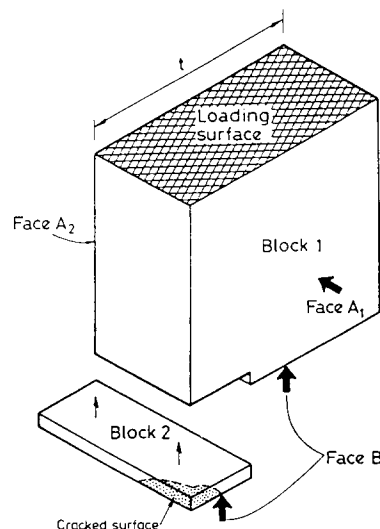
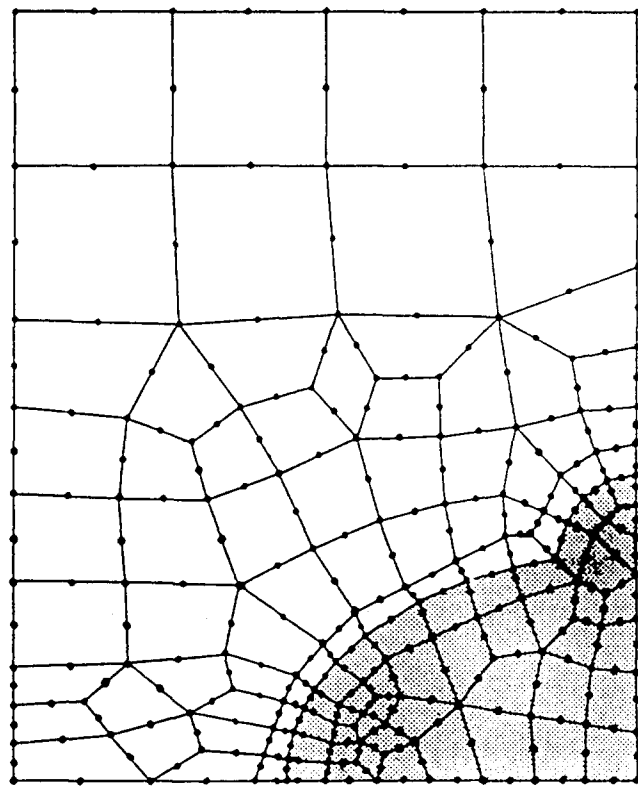

FIG. 2. Schematic of formation of computational model.



• NODE POSITIONS
 ■ CRACKED SURFACE

FIG. 3. 2-D representation of cracked surface on face B of block 2.

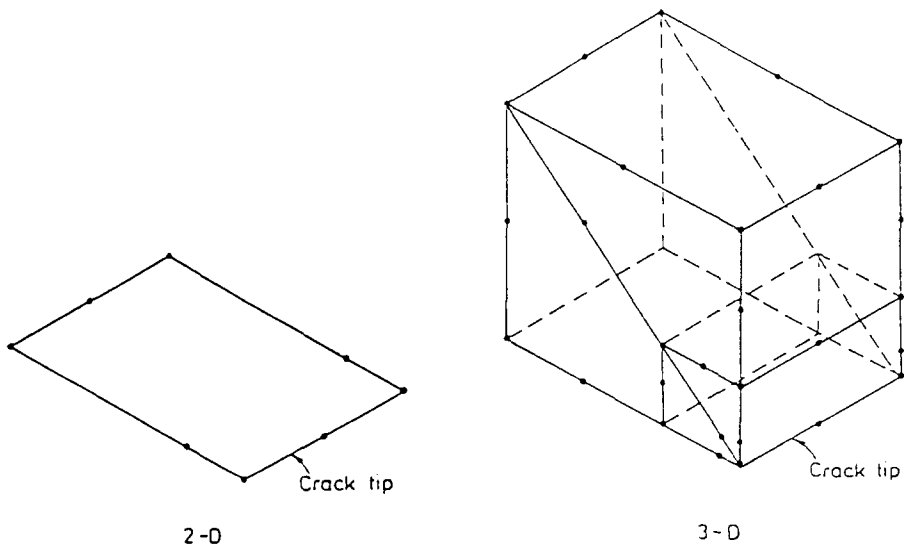

FIG. 4. Expansion of 2-D crack front element into four 3-D elements. Only visible nodes are shown.

that sharp corners rapidly developed into smooth curves as the crack grew and consequently a normal mesh layout was possible. The problems of a crack approaching a free surface are due to the stress condition changing from plane strain within the material to plane stress on the free surface. However, the associated potential error, some 5% [1], of assuming plane strain conditions throughout is an acceptable limitation of the present method especially since good comparisons with experimental results have been obtained.

Quality checks on the accuracy of the K_I computations have been made against both those computed by Newman and Raju [3], for the case of an elliptical surface thumbnail crack and by Murakami and Nemat-Nasser [4, 5] for a slot with a square protrusion defect. These comparisons are detailed by Smith and Cooper [1] and are found to be satisfactory.

PRACTICAL APPLICATIONS

A wide variety of practical problems have been analysed; these include such irregular planar defects normal to the remote applied stresses as semi-elliptical, slot type, deep or shallow cracks as may exist either on or beneath the surfaces of a component. It has generally been found that if a crack is permitted to grow indefinitely it will tend towards an iso- K_I configuration, that is K_I round the boundary of the crack becomes constant. In other words, the ratio of the maximum to minimum stress intensity factor for a particular crack profile, $K_{I_{max}}/K_{I_{min}}$, tends towards unity as the crack develops.

The slot with a square protrusion, shown in Fig. 5, illustrates the effect of both constrained and unconstrained internal corners subject to a uniform remote stress. The greatest initial fatigue growth associated with this shape occurs at the unconstrained (or re-entrant) corner, C, whilst the least occurs at the two constrained corners, B and D. The tendency of the crack to assume an iso- K configuration is clearly shown in Fig. 6. Essentially, therefore, constrained corners have low local K s while re-entrant corners have high local K s [1]. Consequently the growth of arbitrary irregular cracks can be qualitatively predicted.

The interaction and coalescence of two semi-elliptical cracks are investigated by Kishimoto *et al.* [6] and Soboyejo *et al.* [7] and detailed below in Figs 7 and 8. The two cracks grow almost independently until their adjacent crack tips coalesce. There appears to be virtually no fatigue crack interaction before coalescence. After coalescence the crack front forms a single cusp shape and grows as a single larger semi-ellipse. The highest crack growth rates occur during coalescence and this causes a rise in the ratio of K_{max}/K_{min} with the growth of the cracks and is shown in Fig. 8. Consequently the K_{max} to K_{min} ratio does not decrease monotonically; however it does eventually tend to unity after the two cracks form a single larger semi-elliptical crack.

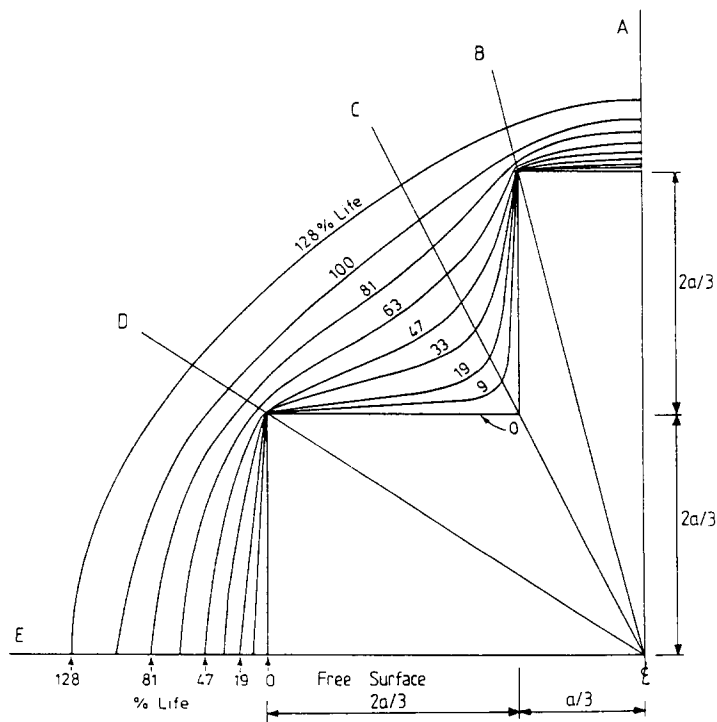

FIG. 5. Fatigue shape development of a slot defect with a protrusion.

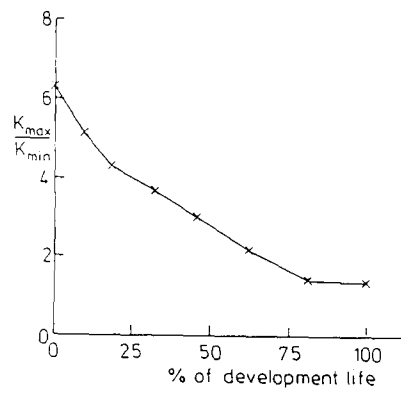

FIG. 6. Variation of K_{max}/K_{min} along crack front as the effect of sharp corners diminishes.

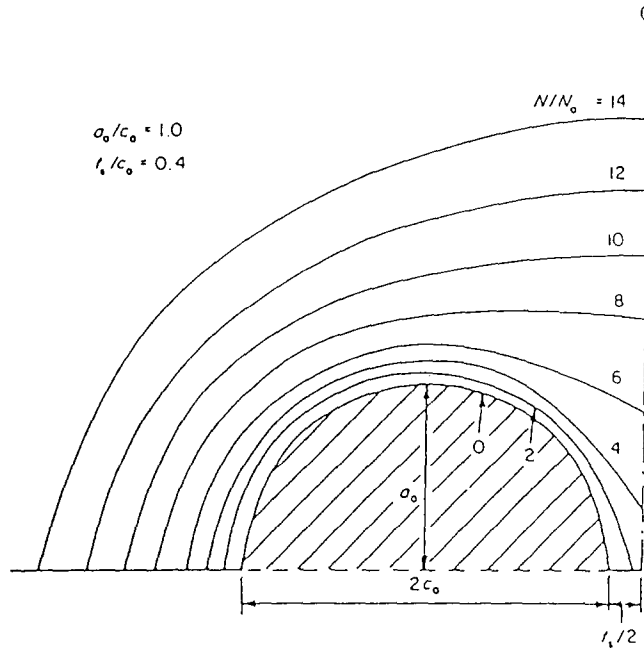

FIG. 7. Shape development of two semi-elliptical surface cracks by fatigue. (Initial aspect ratio $a_0/c_0 = 1.0$)

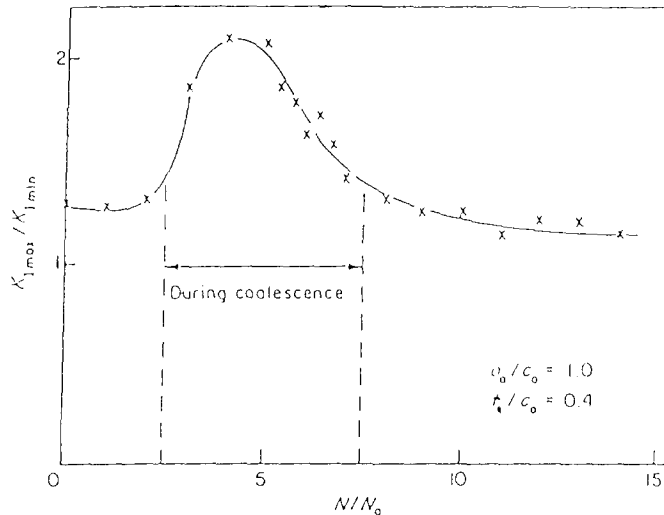

FIG. 8. Variation of K_{max}/K_{min} along crack front during shape development.

Having established these general characteristics associated with the growth of cracks, the model is being developed to analyse further problems and boundary conditions. Surface cracks in components with one external boundary (semi-infinite plate), have been discussed above. Internal cracks which break out to become visible on the surface, and cracks in components with two or more external boundaries, such as leak before break problems, can now be examined by this method.

Figure 9 shows the variation of the computed crack profiles for the growth of a subsurface elliptical defect due to a remote applied tensile stress. The ratio N/N_0 for these curves represents a dimensionless number of loading cycles. The profiles are such that the same number of loading cycles is taken to develop from one contour to the next. The defect is seen to grow uniformly, generally maintaining its elliptical shape, until it approaches the free

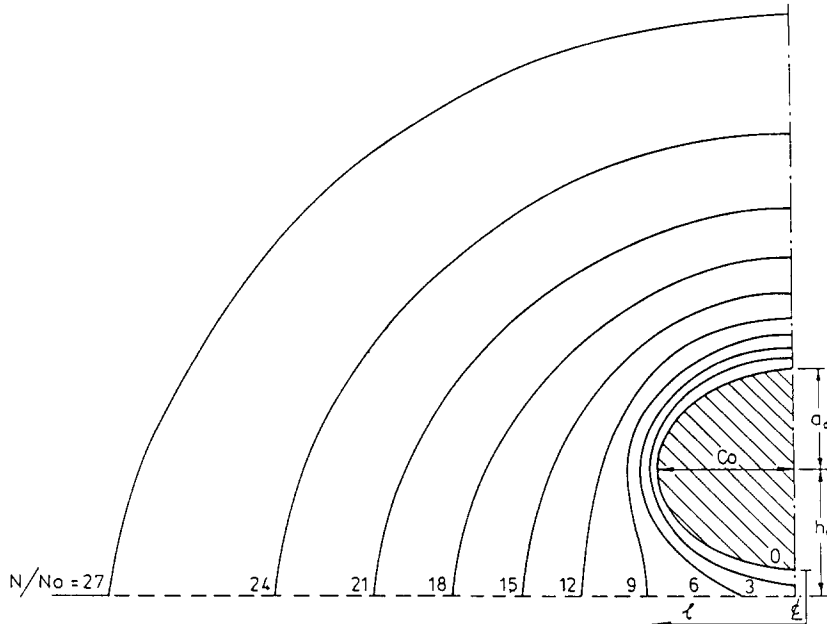

FIG. 9. Fatigue shape development of subsurface elliptical defect.

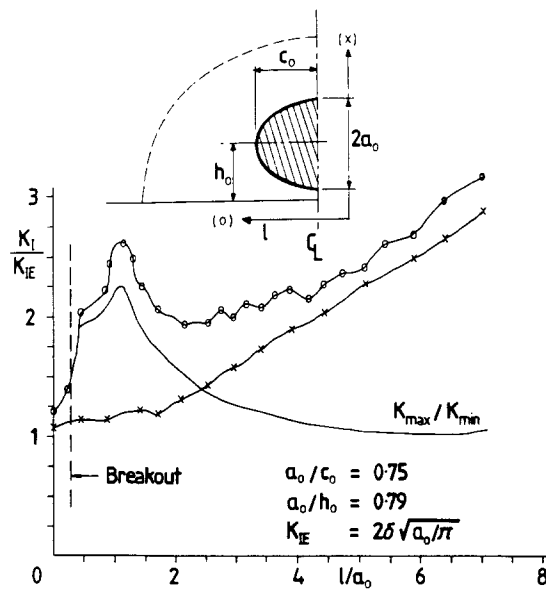

FIG. 10. Variation of K_{max}/K_{min} along crack front during shape development.

surface. The highest values of K_I then occur at the points on the crack front that intersect the material free surface. Consequently the area of most rapid growth occurs along the free surface whilst the growth inwards into the material is virtually negligible. This pattern of growth continues until the crack profile attains a smooth thumbnail appearance, at which stage an iso- K configuration is established. Figure 10 shows the variation of maximum to minimum stress intensity factor as the crack develops. This decreases towards unity but only after rising to its highest value when the crack interacts with the free surface. Indeed, both Figs 9 and 10 are very similar to Figs 7 and 8, respectively, which define the growth and interaction of two semi-elliptical surface cracks.

An interesting result of this particular analysis concerns the observed surface growth rates. An observer examining the surface of this component would see the sudden

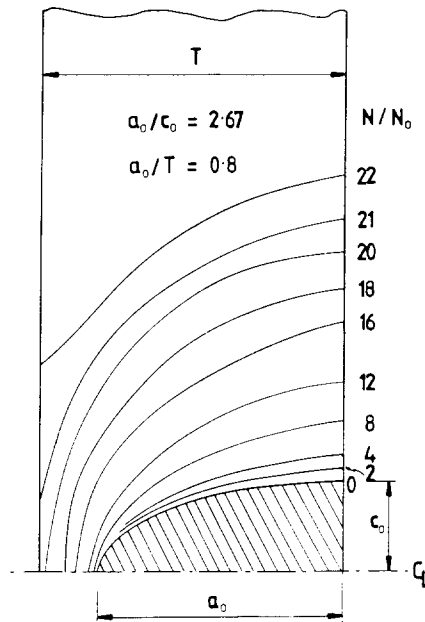

FIG. 11. Shape development of short deep crack in leak before break analysis.

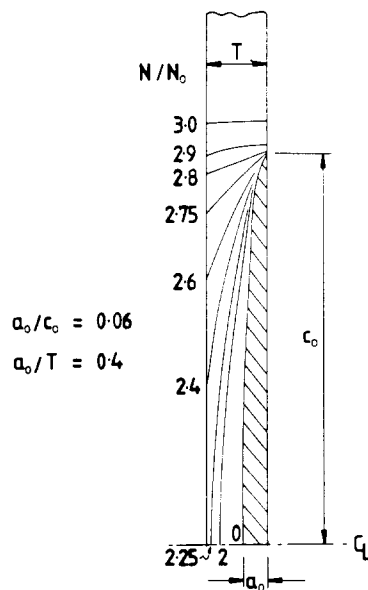

FIG. 12. Shape development of long narrow crack in leak before break analysis.

appearance of a surface crack having a high growth rate which would decrease before accelerating again. From assumption of a semi-elliptical surface crack, the resultant calculated growth rates against stress intensity factor curve would actually be different from the usual Paris law curve. It is suggested, therefore, that such errors in da/dN vs ΔK curves may well be due to incorrectly assuming an internal defect to be a surface defect.

The growth of two extreme flaws (short deep crack and long shallow crack) in a leak before break analysis is detailed in Figs 11 and 12. The flaws are normal to the remote applied tensile stress; the same number of loading cycles is taken to develop the crack from one profile to the next; the ratio N/N_0 represents a dimensionless number of loading cycles. In both cases the cracks grow into smooth thumbnail configurations: growth for the short deep crack is initially highest on the free surface of the plate whilst it is highest inwards into the plate for the long shallow crack. Checks have been made on the stress intensity factors at the beginning and end of the analyses against theoretical values and errors of up to a few per cent were found in all cases.

CONCLUSIONS

The importance of this particular finite element model lies in its versatility and adaptability in analysing so many different classes of planar cracks. The automatic remeshing of the model for following the development of a crack makes such analyses realistic. The trend of different crack shapes to develop into an iso- K configuration, or smooth thumbnail shape, has been established. It has also been shown that the ratio of maximum to minimum stress intensity factor for a crack profile tends towards unity as the crack develops and that the decrease of this ratio is not always in monotonic fashion.

Acknowledgements—Thanks are recorded to MARC for the use of their finite element programs and to both the Marine Technology Directorate of the SERC and the UKAEA for financial support.

REFERENCES

1. R. A. SMITH and J. F. COOPER, A finite element model for the shape development of irregular planar cracks. *Int. J. Press. Vess. Piping*, **36**, 315 (1989).
2. R. S. BARSOUM, On the use of isoparametric finite elements in linear fracture mechanics. *Int. J. Numer. Methods Engng* **10**, 25 (1976).
3. J. C. NEWMAN JR. and I. S. RAJU, An empirical stress intensity factor equation for the surface crack. *Engng Fracture Mech.* **15**, 185 (1981).
4. Y. MURAKAMI and S. NEMAT-NASSER, Interacting dissimilar semi-elliptical surface flaws under tension and bending. *Engng Fracture Mech.* **16**, 373 (1982).
5. Y. MURAKAMI and S. NEMAT-NASSER, Growth and stability of interacting surface flaws of arbitrary shape. *Engng Fracture Mech.* **17**, 193 (1983).
6. K. KISHIMOTO, W. O. SOBOYEJO, R. A. SMITH and J. F. KNOTT, A numerical investigation of the interaction and coalescence of twin coplanar semi-elliptical fatigue cracks. *Int. J. Fatigue* **11**, 91 (1989).
7. W. O. SOBOYEJO, K. KISHIMOTO, R. A. SMITH and J. F. KNOTT, A study of the interaction and coalescence of two coplanar fatigue cracks in bending. *Fatigue Fracture Engng Mater. Struct.* **12**(3), 167 (1989).