



<b>Title</b>	Factors Influencing Wind Energy Curtailment
<b>Authors(s)</b>	Burke, Daniel J., O'Malley, Mark
<b>Publication date</b>	2011-04
<b>Publication information</b>	Burke, Daniel J., and Mark O'Malley. "Factors Influencing Wind Energy Curtailment." Institute of Electrical and Electronics Engineers, April 2011. <a href="https://doi.org/10.1109/TSTE.2011.2104981">https://doi.org/10.1109/TSTE.2011.2104981</a> .
<b>Publisher</b>	Institute of Electrical and Electronics Engineers
<b>Item record/more information</b>	<a href="http://hdl.handle.net/10197/4727">http://hdl.handle.net/10197/4727</a>
<b>Publisher's statement</b>	© 2011 IEEE.
<b>Publisher's version (DOI)</b>	10.1109/TSTE.2011.2104981

Downloaded 2026-05-02 00:27:43

The UCD community has made this article openly available. Please share how this access benefits you. Your story matters! (@ucd\_oa)



© Some rights reserved. For more information

# Factors Influencing Wind Energy Curtailment

Daniel J. Burke, *Student Member*, and Mark J. O'Malley, *Fellow*.

**Abstract**—Non-physically-firm wind generation connections (i.e. those to which curtailment can apply) may be necessary for significant wind integration to congested transmission networks. A study of factors influencing this associated wind energy curtailment is therefore of timely importance. In this paper, the wind curtailment estimation effects of natural inter-yearly wind profile variability, system demand-profile/fuel-price parameter uncertainty, and minimum system inertial constraints are studied in detail. Results indicate that curtailment estimation error can be reduced by appropriate wind data year-length and sampling-rate choice, though a pragmatic consideration of system parameter uncertainty should be maintained. Congestion-related wind energy curtailment risk due to such parameter uncertainty exhibits appreciable inter-locational dependency, suggesting there may be scope for effective curtailment risk management. The coincidence of wind energy curtailment estimated due to network thermal congestion and system-wide inertial-stability issues also has commercial significance for systems with very high wind energy penetration targets, suggesting there may be appreciable interaction between different sources of curtailment in reality.

**Index Terms**-- power transmission, power generation dispatch, power system economics, uncertainty, wind energy.

## I. INTRODUCTION

The low capacity factor of wind energy as an alternative form of electric power generation has significant implications for wind farm transmission access and transmission network design criteria [1]. Wind is most appropriately considered as a variable energy source in long-term network integration studies as it rarely reaches nameplate capacity production in many locations. If optimal transmission system design implies an accommodation of distributed wind energy production for most but not all of the time (i.e. it is uneconomic to design transmission networks for all of the available wind energy [2]), then some level of wind curtailment (i.e. a 'non-firm' transmission connection) will be an obvious consequence. Both the expected value, and equally importantly the risk or uncertainty of wind curtailment estimates will have considerable relevance for non-firm wind capacity investment in deregulated power systems. A detailed consideration of the various and somewhat interdependent factors influencing curtailment is therefore necessary.

As wind energy is a fluctuating and partially dispatchable generation source, curtailment investigation must be considered within a probabilistic rather than deterministic study context. While advanced wind power time series simulation methods have been reported in the literature [3], wind production data based on historical behaviour is often the basis for many wind transmission integration studies applied in practice [4],[5]. Synchronously recorded historical power output data is useful in that it will inherently represent any multivariate spatial dependencies, though often there is only a limited amount of data available for study. Wind profiles may exhibit both significant inter-yearly variation as well as appreciable short term intra/inter-hourly variability in some areas - important questions arise such as how many years of historical data and what data sampling frequency are required to accurately estimate respective wind energy curtailment indices. Historical wind power data-timeframe considerations of this nature have been shown to strongly impact wind capacity credit estimation in [6] for example.

While such wind profile timeframe modeling issues will no doubt influence wind curtailment estimation, long-term uncertainty associated with other power system parameters will also be of importance. For example the power flow implications of future customer demand shaping with smart-metering and electric transportation, combined with fossil fuel/carbon price volatility, are relatively unknown at present, and may even fluctuate dynamically as the future system evolves in time. Such model parameter uncertainty contributes to wind curtailment estimate variation, i.e. curtailment 'risk'. Excessive wind curtailment risk, even for network locations where the 'expected' curtailment level in itself is quite low, will be problematic from an investment security perspective as wind capacity is a relatively capital-intensive investment option. Given that wind development is usually distributed at multiple locations in the power system network however, then a study of the co-dependency of wind curtailment estimate variations between distinct locations allows an investigation of how such long term curtailment uncertainties might possibly be overcome from a risk management perspective. Anti-correlated curtailment risks will be particularly advantageous in this respect.

At low to medium wind energy penetration levels, network congestion will be the principle factor influencing wind curtailment values. At very high penetration levels however, sometimes the total wind generation available may approach or even exceed the total customer load demand in small regional or island power system areas. Therefore some wind energy may also have to be curtailed for load balancing purposes to

---

This work was conducted in the Electricity Research Centre, University College Dublin, Ireland, which is supported by the Commission for Energy Regulation, Bord Gáis Energy, Bord na Móna Energy, Cylon Controls, EirGrid, ESB Energy International, ESB Energy Solutions, ESB Networks, Gaelectric, Siemens, SSE Renewables, SWS Energy and Viridian Power & Energy. The work of D. J. Burke was supported in part by the Sustainable Energy Authority of Ireland through a postgraduate research scholarship from the Irish Research Council for Science Engineering and Technology.

The authors are with the School of Electrical, Electronic and Mechanical Engineering, University College Dublin, Dublin 4, Rep. of Ireland (e-mail [daniel.burke@ucd.ie](mailto:daniel.burke@ucd.ie), [mark.omalley@ucd.ie](mailto:mark.omalley@ucd.ie); telephone +353 1 716 1857; web <http://erc.ucd.ie>).

keep a minimum number of conventional units online in the unit-commitment procedure for related system inertial or network dynamic stability reasons [7],[8]. It is presently unclear what the coincidence of such concerns with network thermal-congestion problems will be, as sufficiently detailed studies of these issues are often completed separately [9]. For example if there is already wind curtailment required due to local network congestion, then the load balancing/inertial-stability excess in total wind power availability may not occur in the first place. Whether the overall net level of wind curtailment will be equal to or less than the algebraic addition of these separate results is furthermore an issue of considerable economic significance for wind farm owners in reality.

This paper presents detailed studies of the effects and possible coincidence of these factors which influence overall wind energy curtailment patterns in congested transmission networks. The characteristics and practical details of the power system and related security-constrained optimal power flow (SCOPF) routine that form the common basis for each study are outlined in Section II. Extensive multi-year historical recorded wind power data is then investigated in Section III to quantify the impacts of natural inter-yearly wind profile variation and data-sampling rate on curtailment estimation. With a suitably stable and compact time-frame representation of the wind data chosen to negate such inherent wind profile variability effects, the influence of power system parameter uncertainty and inertial-stability unit commitment constraints on wind curtailment risk is subsequently investigated in Sections IV and V respectively. Relevant discussions and conclusions are then given in Sections VI and VII.

## II. TEST POWER SYSTEM AND SCOPF IMPLEMENTATION

### A. Power System Network, Generation and Wind Data

The test system used in the analyses of this paper is illustrated in Fig.1. This has a 35-bus, 54-line network, denoted as ‘Area 1’ (based on a very simplified model of the Irish ‘All-Island’ 220/275/400kV high-voltage transmission system). It contains a mixture of base-load and mid-merit fossil-fuel (coal and peat) steam turbine generation, combined-heat-and-power gas plants (CHP), combined-cycle gas turbines (CCGTs), higher-efficiency aero-derivative gas turbines (ADGTs), lower-efficiency open-cycle gas turbines (OCGTs), as well as a few gas/oil-distillate ‘peaking’ units, amounting to 10.4GW conventional plant capacity overall. 500MW of HVDC interconnection capacity to a much larger separate power system denoted as ‘Area 2’ (based on an approximate model of the Great Britain generation portfolio) is available at both buses 12 and 34, denoted as IC-1 and IC-2 in Fig.1. Conventional plants in Area 2 are grouped approximately into multiple generation capacity blocks of similar plant-type, all connected at a single transmission node. Conventional plant performance data, seasonal natural gas fuel price variations, load profile, load magnitude (accounting for projected load growth to a maximum peak value of 9.61GW), and the

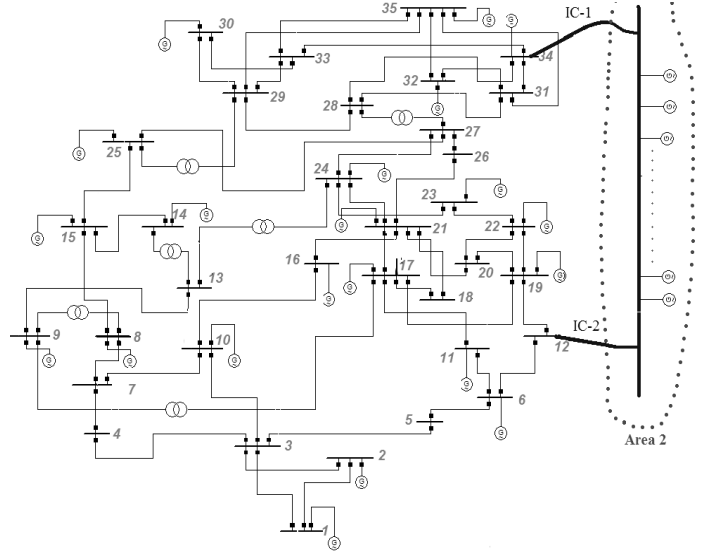

Fig.1 – the test power system under investigation.

assumed load geographic distribution are consistent with [5]. Load profile information for Area 2 was sourced from [10]. Additional information on the test network branch reactance and thermal capacity parameters (chosen so that no congestion occurs at the zero wind penetration level), the assumed system geographical load spread, and the conventional generation portfolio network locations as applied in this investigation, are given in the Appendix.

Synchronously recorded historical multivariate wind power data from multiple geographically distributed existing wind farms on the Irish power system, recorded over varying numbers of years and at 15-minute sampling resolution, was used as the database for the wind energy curtailment studies of this paper. This multivariate power output data was linearly re-scaled to model different installed wind capacity levels positioned at various locations on the test system network, as appropriate for each study – further information is detailed as necessary in Sections III, IV and V below. Coincident 15-min resolution load time series data was taken from the Irish power system for use with the test power system of Fig.1, with inter-year normalization by peak-load applied to remove any demand-growth patterns present.

### B. Network Congestion Study Implementation Assumptions

Application of multi-year, high-frequency data to wind energy curtailment investigation, under a wide number of power system parameter sensitivity analyses, is a very computationally demanding task. Many hundreds of thousands of individual optimisation solver routines are performed in the test system analyses of this paper for example. A judiciously simplified model is therefore useful to make the curtailment studies of this paper tractable so that general trends and concepts can be established. In real power system applications where precision is more critical, use of a fully rigorous model would of course be necessary. When considering the specific sensitivity influence of any individual parameter, its’ salient features should be retained, while other issues (whose particular effects may already be somewhat understood) can

justifiably be simplified in some ways. This pragmatic approach forms the basis of the network congestion modelling outlined in this paper – the historical wind data sampling effects in Section III are first resolved to a more compact representation prior to the more general parameter uncertainty investigation in Section IV, for example.

A lossless linear DC security-constrained optimal-power-flow dispatch model was used for the curtailment sensitivity-analysis context of the three studies outlined in Sections III, IV and V. This relatively simple linear-programming model applied any single network or generation ‘N-1’ contingency of the test system as the operational security criteria to be satisfied by the generation dispatch solution at each time-step. Conventional generators were dispatched on the basis of single-cost energy bids, and wind power marginal costs were taken as zero. All model development was carried out in MATLAB [11] and GAMS [12], using the MATLAB/GAMS interface available at [13].

The unit-commitment problem for real power systems with high wind penetration levels influences the power generation schedule for two main reasons. Firstly, for some extreme (but typically low-probability) operational-timeframe scenarios, wind energy may have to be curtailed to ensure that adequate conventional generation flexibility is maintained online with regard to operational wind variability and forecast uncertainty effects. This is an indirect result of conventional generation start-up times, minimum up- and minimum down-times, ramp-rate limits etc. Stochastic mixed integer optimisation models of such operational wind management tasks have already been outlined in detail with the studies of [14], [15], [16] and their context in longer-term power system planning models furthermore considered in [17]. As such models are highly computationally demanding, and as sequential wind variability effects are not primarily influential with respect to understanding the three sensitivities considered in this paper, they are not included in the analyses of Sections III and IV.

On the other hand, in real power systems the system operator must make sure that a minimum number of conventional units are kept committed online at all times for system dynamic stability etc – wind curtailment may also occur for this reason, particularly if high wind power output coincides with low demand level. At high wind penetration level, the contribution of this effect to overall wind curtailment levels is likely to be more influential than the sequential variability management problem, as might be suggested by the results of [17]. A good approximation of the contribution of this unit-commitment effect to wind curtailment is therefore indeed included in this paper (albeit using a rounded-relaxation linear programming based approximation of a mixed integer approach), and is outlined in detail in Section V.

### III. HISTORICAL DATA TIMEFRAME MODELING

#### A. Case Study Details

Eight consecutive years of recorded historical wind power output data was available at 15-minute sampling frequency

from 4 separate existing wind farms located on the Irish power system (wind data from the other sites was available with lesser timeframe length). This wind data was linearly re-scaled to arbitrary 750MW capacity wind farms connected to buses 9, 11, 13 and 17 on the test power system in Fig.1. In total therefore, ~ 280,320 individual linear programming based SCOPF analyses were carried out to model the wind energy curtailment at each respective wind farm over the entire historical time series dataset. The SCOPF results were subsequently filtered at 15-min, 30-min, 1-hourly, 2-hourly, 4-hourly, 8-hourly, 12-hourly and 24-hourly sequential time-segment resolution to investigate data sampling frequency impacts on the wind energy curtailment estimation. To preserve any diurnal characteristics in the wind data, the low frequency samplings were carried out randomly in each respective sequential data segment. The SCOPF results were also filtered for various year-length timeframes from 1 year of data alone to the full 8 year dataset – for example there are 28 ( ${}^8C_2$ ) possible ways to select any two years of data from the original 8-year set. This timeframe-filtering of the SCOPF results allows an investigation of the wind energy curtailment estimation error associated with a limited historical data timeframe at low sample resolution, when compared to the original 8-year 15-min dataset.

Two separate SCOPF sensitivity analyses were also carried out with respect to conventional generation gas fuel price and the customer load demand profile for the 8-year, 15-min historical database. Gas price was arbitrarily increased by 25% from the base case scenario and the total system demand profile was reduced to 95% of its base case pattern. Observing the curtailment uncertainty effects of these limited sensitivity analyses puts the historical data inter-yearly/sample-rate curtailment estimate variations in context of typical power system parameter uncertainty effects, allowing a prudent choice of the number of historical data samples to retain for subsequent investigations in Sections IV and V.

#### B. Case Study Results

A sample illustration of the effect of limited data timeframe length on the estimation of wind energy curtailment at Farm-9 is given in Fig.2, with the vertical columns representing all the various possible individual data-year combinations (each applied with 15-min data sample resolution). Depending on the year in question, if only 1 year of study data was available for example, the estimated wind energy curtailment could vary anything from 1.4% to 2.4% of total available energy, compared to the full 8-year dataset value of 1.86%. Analogous to the wind capacity credit studies in [6], more years of data available progressively reduces the variance of the curtailment estimation error. The corresponding effect of limited data year-length on the estimated Farm-11 wind energy curtailment is illustrated in Fig.3. Similar effects are evident for the wind farms at buses 13 and 17.

The mean absolute value of the wind energy curtailment percentage error, averaged over the four wind farms in the system, is summarized in Fig.4 for all such possible historical

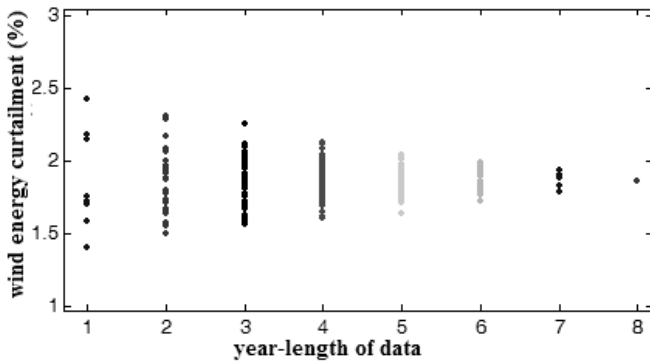

Fig.2 – variations in wind energy curtailment at Farm-9 with respect to number of years of data (15-minute sample resolution).

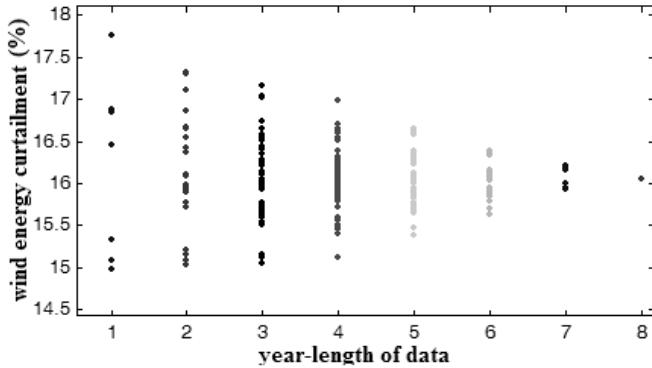

Fig.3 – variations in wind energy curtailment at Farm-11 with respect to number of years of data (15-minute sample resolution).

data year-length and sampling frequency combinations. For example, 4-years of wind data sampled at 8-hourly resolution give a system-averaged expected curtailment error of approx 8%. From the slope of different segments of the graph in Fig.4, the incremental value of acquiring additional data to wind energy curtailment modeling is clearly relative to how much is available already. Wind data timeframe modeling issues will have an effect on estimated wind capacity factor also. The corresponding mean absolute value of the wind energy capacity factor error, again averaged over the four wind farms, is given in Fig.5. Interestingly the capacity factor error reduces linearly with respect to timeframe yearly length across all parts of the surface, and sampling resolution has much less of an influence when compared to the wind farm curtailment error in Fig.4. Wind power output rarely reaches maximum rated capacity over extended time periods of study, and thus wind curtailment estimation accuracy will effectively be based on much fewer occurrences compared to wind farm capacity factor estimation.

The variation in the wind energy curtailments for the different power system sensitivity analyses is given in Table-I. The wind energy curtailment estimate variation for these wind farms due to power system parameter uncertainty is of the order of 5-10% of the base case values. Comparing this parameter uncertainty effect with the natural inter-yearly wind profile and sampling frequency variations illustrated in Fig.4 allows a pragmatic consideration of the value of additional sample data in wind energy curtailment estimation studies. For this test system example, 4-years of wind data sampled at 8-

hourly frequency gives curtailment accuracy (on average, though outliers will exist) comparable to that associated with typical uncertainty in the test power system model itself – therefore the value of additional wind timeframe sampling inclusion in excess of a suitable level must be considered with regard to the additional computational burden. This is especially important in wind power transmission optimization applications where repeated multi-year wind time series SCOPF routines are often sub-problem steps of iterative decomposition schemes [19] – even if many years of high-frequency data was available for study it may not be computationally sensible or even necessary to use all of it to get suitably good model solutions for such problems.

On the justification of these historical data timeframe study results, wind power output profiles in this test system were subsequently modeled using 4 years of multivariate wind power data sampled at 8-hourly period, giving 4380 samples in total for the analyses outlined in Sections IV and V.

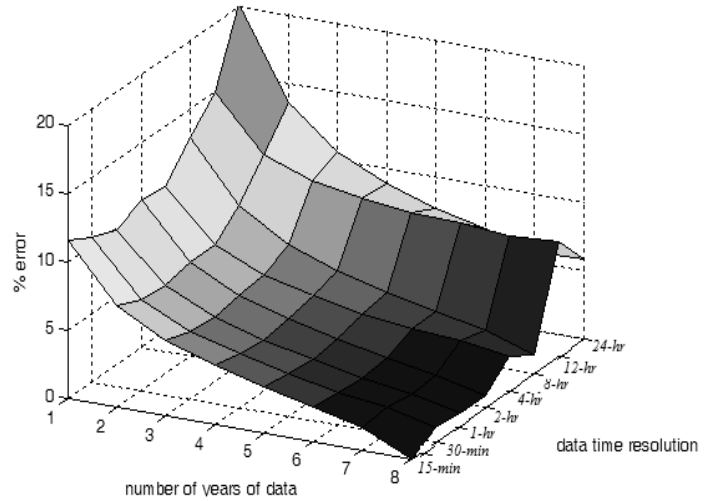

Fig.4 – system-averaged mean absolute wind energy curtailment error with respect to number of years of data and data sampling resolution.

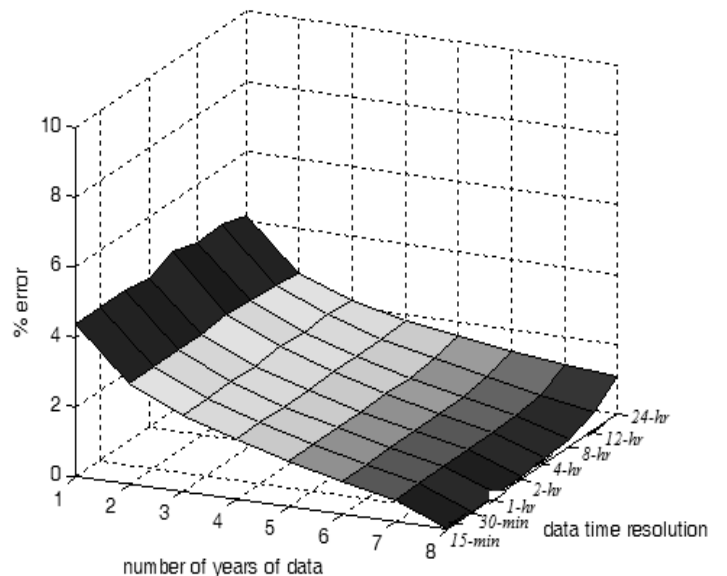

Fig.5 – system-averaged mean absolute wind capacity factor error with respect to number of years of data and data sampling resolution.

TABLE-I

WIND ENERGY CURTAILMENT % - EFFECT OF SENSITIVITY ANALYSIS

	Farm 9	Farm 11	Farm 13	Farm 17
Base Case	1.86	16.05	1.8	18.27
95% Load Profile	1.66	16.33	1.7	18.19
125% Fuel Price	1.87	15.21	1.95	20.51

#### IV. INTER-LOCATIONAL CURTAILMENT RISK DEPENDENCY

##### A. Case Study Details

The impact of future power system model parameter uncertainty on the network congestion related wind energy curtailment indices was illustrated with Table-I, for two simple sensitivity analyses. This type of wind curtailment model uncertainty constitutes a direct risk to wind farm investment. However, the columns of Table-I illustrate that the impacts of load profile reduction and gas price increase had opposite impacts on the individual curtailments of wind farms at buses 11, 13 and 17. Interestingly, the rows of Table-I also illustrate that the wind energy curtailment at buses 13 and 17 increased in the high gas price scenario with respect to the base case, while the curtailment at bus 11 simultaneously decreased. Table-I therefore underlines the possible variations of wind energy curtailment estimation at each bus for alternative parameter uncertainty scenarios, and indeed curtailment variation inter-dependencies for wind plants installed at different network locations – this curtailment risk diversity characteristic is worthy of more significant investigation with a detailed case study in this Section.

In this particular case study, to investigate wind curtailment risk dependency across a suitably large number of network locations, 10 distinct wind farm installations were assumed connected at buses 3, 5, 7, 9, 11, 13, 15, 17, 25 and 33. On the justification of the historical data timeframe study as outlined in Section III, wind power output profiles were modeled using the appropriate 4-year data-length and 8-hour sampling rate choice with 4380 samples overall. Instead of an arbitrary wind capacity allocation assumed connected to each location as applied in Section III, this particular study proceeds from the basis of an optimal non-firm wind capacity investment solution determined by the methodology of [19]. This methodology uses the base-case load-profile/fuel-price parameter values, determining a least-cost distributed wind capacity placement for a given total-system wind capacity connection target. The optimal wind capacity placement results therefore implicitly specify a least-cost wind curtailment basis to which sensitivity analysis perturbation is applied in this case-study. A selection of optimal wind capacity allocation solutions are given in Table-II for this test-system, for different total wind capacity target levels. The wind energy curtailment risk of the optimal 6GW total wind capacity solution was investigated in this case-study, corresponding to a reasonably high ~ 29.7% total wind energy penetration.

Distributed system load profile, coal/gas/peat conventional plant fuel-price and carbon-price were the uncertain system

TABLE-II

OPTIMAL NON-FIRM WIND CAPACITY ALLOCATIONS, (MW)

System Node	3	5	7	9	11	13	15	17	25	33
Total Wind Target (GW)										
6	508	812	637	0	372	651	854	397	717	1051
7	1145	854	639	60	334	683	889	442	812	1140
8	1371	905	723	167	415	742	990	475	935	1277
9	1520	987	790	266	484	804	1117	522	1067	1444

parameters allowed to vary in the curtailment risk analysis. 100 different samples were taken from the system parameter uncertainty model to set-up 100 distinct background power system scenarios, to each of which a separate 4380-sample SCOPF time-series wind curtailment investigation was then applied. The choice of how to model fuel-price/load-profile uncertainty is generally subjective to some extent (i.e. it may be difficult to objectively justify any particular fuel price probability model for example), so therefore the curtailment risk impacts of two distinct system parameter uncertainty models were investigated:

- Case I – Fuel and carbon prices were allowed to vary independently of each other with uniform distributions chosen to be centred around the original base-case deterministic values as follows – gas (75-125% of base-case value), coal (90-110% of base-case value), peat (90-110% of base-case value) and carbon (80-120% of base-case value). The individual system bus load growth uncertainties were assumed to vary with uniform distributions, independently of each other and also independent of the fuel/carbon prices, with a linear-scaling parameter spread around 90-102.5% of their original base-case values.
- Case II – In the second parameter uncertainty model, the fuel and carbon price statistical representation was kept the same as Case I, but the individual network bus load growth uncertainties were instead assumed to have a correlated Gaussian statistical dependency. The bus loads were assumed to have a mean uncertainty value of 96.25% of their base case values, a standard-deviation of 3.125% of their base case values, and an inter-locational correlation coefficient of 0.7.

##### B. Case Study Results

The mean wind energy curtailment percentages for the different wind farms, with respect to the two alternative system parameter uncertainty model sample sets described in Section IV-A, are presented in Table-III. No curtailment occurred for the farms at buses 3 and 9. The scatter plots of wind energy curtailment risk dependency between Farms 5 and 11, and Farms 13 and 15 are illustrated in Fig.6 and Fig.7 respectively for the Case I parameter uncertainty model. The spread of curtailment risk in each wind farm due to model parameter uncertainty again puts the inherent wind profile variability related curtailment error characteristics of Fig.4 in perspective.

TABLE-III  
 MEAN WIND ENERGY CURTAILMENTS, (%)

Wind Farm	3	5	7	9	11	13	15	17	25	33
Case I	-	0.87	0.3	-	2.44	2.83	4.45	6.53	3.09	4.11
Case II	-	0.89	0.32	-	2.53	3.02	4.47	6.72	3.1	4.07

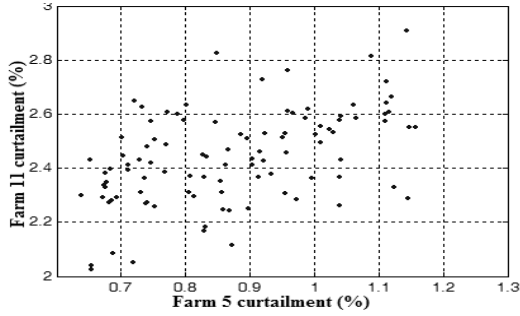

Fig.6 – Wind curtailment risk dependency for Farms 5 and 11 (Case I).

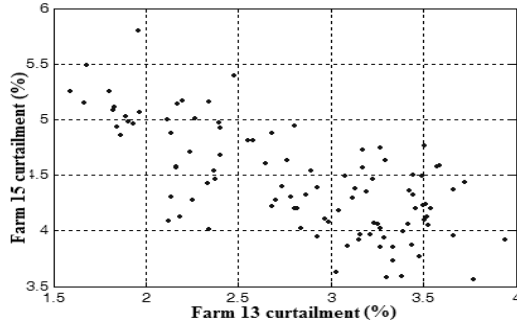

Fig.7 – Wind curtailment risk dependency for Farms 13 and 15 (Case II).

TABLE-IV

DISTRIBUTED WIND ENERGY CURTAILMENT RISK CORRELATIONS – CASE I

WIND FARM	5	7	11	13	15	17	25	33	SYSTEM TOTAL
5	1	0.17	0.49	0.14	0.90	0.20	0.03	-0.04	0.37
7	0.17	1	0.38	0.33	0.12	0.47	0.23	-0.20	0.51
11	0.49	0.38	1	0.27	-0.01	0.32	0.14	-0.17	0.39
13	0.14	0.33	0.27	1	-0.69	0.76	0.64	-0.85	0.36
15	0.09	0.12	-0.01	-0.69	1	-0.44	-0.44	0.74	0.20
17	0.20	0.47	0.32	0.76	-0.44	1	0.58	-0.56	0.61
25	0.03	0.23	0.14	0.64	-0.44	0.58	1	-0.55	0.64
33	-0.04	-0.20	-0.17	0.84	0.74	-0.56	-0.54	1	-0.01

TABLE-V

DISTRIBUTED WIND ENERGY CURTAILMENT RISK CORRELATIONS – CASE II

WIND FARM	5	7	11	13	15	17	25	33	SYSTEM TOTAL
5	1	0.76	0.88	0.39	0.71	0.42	-0.00	0.59	0.83
7	0.78	1	0.91	0.49	0.71	0.62	0.10	0.57	0.93
11	0.88	0.91	1	0.47	0.77	0.47	0.04	0.64	0.93
13	0.39	0.49	0.47	1	-0.14	0.81	0.79	-0.30	0.60
15	0.71	0.71	0.77	-0.14	1	0.03	-0.48	0.94	0.67
17	0.42	0.62	0.47	0.81	0.03	1	0.66	-0.13	0.69
25	-0.00	0.10	0.04	0.79	-0.48	0.66	1	0.57	0.28
33	0.59	0.57	0.64	-0.30	0.94	-0.13	-0.57	1	0.54

Trends in Fig.6 and Fig.7 also indicate that the curtailment risk is clearly locational in nature – Farms 5 and 11 have a slightly correlated curtailment risk (that is they both tend to be over/under curtailed together), while the curtailment risks at Farms 13 and 15 are anti-correlated (when either is curtailed more than expected, the other is curtailed less). Wind curtailment risks that are independent or as anti-correlated as possible may be useful from a collective risk sharing perspective – for example the total wind curtailment risk across both Farms 13 and 15 is much lower than that across Farms 5 and 11 considered together, as Farms 13 and 15 will generally compensate one another.

The overall curtailment risk dependencies are summarized with linear correlation metrics in Table-IV and Table-V respectively for the Case I and Case II system parameter uncertainty assumptions. The right-hand column gives the curtailment risk correlation of each individual wind farm with variation in the total curtailed wind energy in the system as a whole. For the Case I uncertainty model in Table-IV there are quite a number of anti-correlated inter-locational risk dependencies, due to adjacent network locations or proximity to conventional plants of particular fuel-types. Wind energy curtailment risk at Farm 33 in particular is anti-correlated to some extent with almost every other wind farm location. The risk dependency of each individual site with the system-total wind energy curtailed is also quite low on average, indicating that if the Case I uncertainty model were accurate (which assumes all parameter uncertainties are independent) then both effective inter-locational and system-wide curtailment risk sharing mechanisms might be conceptually feasible through an intelligent wind plant portfolio location choice.

Table-V illustrates the strong impact of the uncertainty modeling assumptions on the overall risk dependency estimation process however. The Case II correlated Gaussian load uncertainty case causes much greater positive dependency in the curtailment risk estimates. For example curtailment risks at buses 5, 7 and 11 are much more dependent than in Case I, though Farms 25 and 33 are still somewhat independent of the general system-wide wind energy curtailment pattern. The standard deviation of the system total wind energy curtailment risk in Case II is also double that of Case I, as the variance of a sum of strongly correlated risks will always be greater than the variance of a sum of independent/anti-correlated risks. Effective system-wide risk sharing will thus be more difficult if Case II is an accurate model of the power system parameter uncertainties, though for each wind farm there is still at least one other location that has low or even negative curtailment risk dependence, as evident in Table-V.

## V. INERTIAL/CONGESTION CURTAILMENT DEPENDENCY

### A. Case Study Details

The 7, 8 and 9GW optimal non-firm wind capacity solutions in Table-II (corresponding to ~ 35-40% total wind energy penetration levels) were used as the system configuration basis

for this particular case-study. With this approach applied (as in Section IV) the initial network congestion related curtailment levels have a minimum-cost justification [19]. To model power system minimum generation commitment levels (which are really integer decisions) within the linear programming SCOPF analyses, a simple inertial constraint approximation of the true mixed-integer representation was implemented using a rounded-relaxation procedure. From the optimal solution of the SCOPF model, iteratively constraining the next-least-cost unit above its minimum generation level and then re-solving ensured that the equivalent of more than 5 large-scale synchronous conventional units is maintained online at all times. For example, four large CCGT generators and two smaller peat generators, or three large coal generators and two CCGTs would be sufficient, depending on the least-cost decisions with respect to energy and congestion costs. Any wind generation causing the net-load to drop below this critical minimum conventional generation level would have to be curtailed. Using the same 4380-sample historical data year-length and sampling rate choice as justified by the wind profile variability analysis of Section III, three separate case study investigations were implemented for each of the 7, 8, 9GW wind capacity levels:

- Case A – In this case, the minimum inertial constraint was applied without including SCOPF network constraints – this models curtailment from detailed dynamic studies without network limits included [7].
- Case B – In this case, the SCOPF network constraints were included but no inertial constraint was applied – this models the results from network analyses that do not consider practical unit commitment inertial problems with instantaneously high wind output.
- Case C – In this case, both the inertial and SCOPF network constraints were included together, modeling the least-cost operational patterns and overall wind curtailment likely to occur in reality.

## B. Case Study Results

The system-total wind energy curtailment results for Cases A, B and C at the 7, 8, and 9GW installed wind capacity levels are given in Table VI as percentages of the respective total available wind energy. At the high levels of installed wind capacity under investigation, Case A illustrates that some level of inertial-constraint related wind curtailment is necessary at very high instantaneous wind power output. However the negligible differences between the system-total wind curtailment results for Cases B and C (for all three wind capacity installation levels) indicate that the inertial constraint wind curtailment instances identified by Case A are almost entirely contained as a subset of the network congestion related wind curtailment instances in Case B. A typical scatter-plot of the Case A and Case B curtailment instances is given in Fig.8 for the 8GW installed wind capacity level, with the corresponding time series plot given in Fig.9. These illustrations further underline the coincidence of the curtailments identified by the two separate analyses.

TABLE-VI  
WIND ENERGY NETWORK/INERTIAL CURTAILMENT VALUES, (%)

Wind Level	7 GW	8 GW	9 GW
Case Study			
A	0.375	1.1819	2.5129
B	6.8628	11.0409	15.4934
C	6.8599	11.0436	15.4964

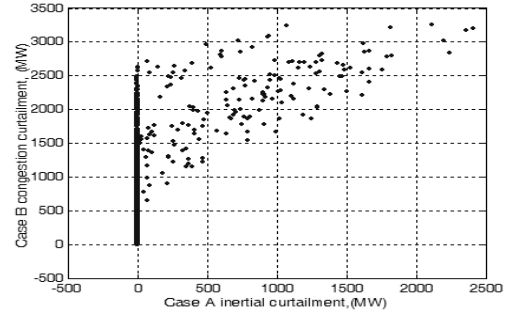

Fig.8 – Scatter plot of inertial/network-congestion curtailment –8GW wind.

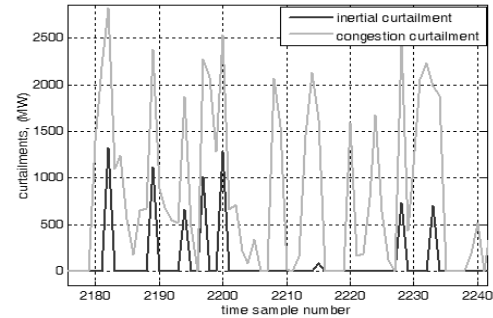

Fig.9 – Time series of inertial/network-congestion curtailments –8GW wind.

## VI. DISCUSSION

Non-physically-firm wind farm connections will allow the harvesting of much more wind energy from a given transmission network investment. Wind farm development is very capital-intensive, with revenue pay-back over a long timeframe. Effective curtailment risk management schemes in deregulated power systems will be a key enabling factor in supporting non-firm wind investment therefore. Using a relatively simple SCOPF model, this paper has identified the physical existence of inter-locational and system-wide curtailment risk diversity, though how such characteristics are exploited with respect to financial or regulatory mechanisms is equally important. Curtailment is not the only risk to wind development of course – if wind farm operators compete freely as price-makers in the market [20] (as opposed to depending purely on renewable support schemes [21]) then the effect of fuel or demand uncertainties on the basic energy price revenues may overshadow any energy volume curtailment risks. Curtailment levels could also be influenced by wind generators using negative bidding in the market. The significant differences in market remuneration and support schemes for renewable energy in many power systems preclude a universal conclusion on such issues in this paper – only curtailment volume risk due to network congestion and/or inertial stability as outlined in Sections IV and V has been considered in this analysis.

Previous studies have identified the avoidance of curtailment due to excess system-wide wind power availability and minimum system inertial constraints as a key factor improving the cost-effectiveness of very-large-scale energy storage investment [18]. However, the results of this paper, Section V in particular, indicate that in a transmission system with a non-physically-firm wind connection strategy, a study of the economics of such centralized storage services may be much more complex than determined by such a generation production-costing study alone. Wind is typically distributed in nature, so therefore the excess instantaneous wind energy, that appears to be available for storage and usage later, may not be transferable to large centralized storage units if most economic dimensioning of transmission infrastructure for wind energy sources is applied. Further study is required to investigate this issue in greater detail. Other factors of influence not included in this paper’s analysis such as ramp-rate unit commitment limits and voltage stability may also affect the overall curtailment estimates, and could be considered in future works.

Many of the issues raised in this paper will become most apparent at medium to high wind penetration levels. With large-scale wind investment, transmission expansion will alleviate wind energy curtailment due to network congestion, and greater interconnection may reduce excess wind availability above the load-balancing requirement – the tradeoff between the factors discussed in Section V will be dependent on such investment decisions. Active network management with remedial action schemes managing congestion may also reduce wind curtailment in the short term until long-term investment projects materialize [22].

VII. CONCLUSIONS

This paper has illustrated the influence of wind power data historical timeframe modeling, power system parameter uncertainty, and minimum system inertial unit commitment constraints on the curtailment indices of distributed wind energy. There can be appreciable inter-yearly variation in estimated wind energy curtailment due to natural wind profile variations, and very low data recording frequency will also lead to equally significant sampling error. Additional data availability will reduce the estimation error appropriately, but curtailment study dimensionality selection should always be framed within the context of inherent power system load-profile and fuel-price uncertainties, among other variable parameters. Their influence on curtailment estimate risk may be equally if not more pronounced. There may be appreciable network congestion related curtailment risk dependency between different power system locations, potentially giving scope for effective risk management strategies. Precise evaluation of inter-locational curtailment risk dependency is heavily influenced by the power system uncertainty modeling strategy though. Interaction between different sources of wind curtailment will be important to study – for example wind curtailment estimates due to inertial constraints may be a somewhat overlapping subset of curtailments already caused by network congestion, and thus the net effect on wind farm

investment profitability may not be as extreme as if they were totally independent.

VIII. APPENDIX

TABLE A-I  
TEST POWER SYSTEM NETWORK BRANCH INFORMATION

FROM-TO BUS	X <sub>L</sub> (100 MVA BASE)	CAPACITY (MW)	FROM-TO BUS	X <sub>L</sub> (100 MVA BASE)	CAPACITY (MW)
1-2	0.02	376.2	18-21	0.044	178.5
1-3	0.02	428.2	19-20	0.01	599.8
2-3	0.011	428.2	19-22	0.01	499.8
3-4	0.039	394.12	20-21	0.01	558.1
3-5	0.075	465.7	20-22	0.01	570.1
3-10	0.073	490.1	21-24	0.02	519.4
4-7	0.084	483.4	21-26	0.038	872.8
5-6	0.02	775.1	22-23	0.003	520.8
6-11	0.06	389.7	23-24	0.008	476.7
6-12	0.076	454.9	24-27	0.053	897.3
7-8	0.007	954.1	25-27	0.095	430.6
7-10	0.061	405.3	25-29	0.025	746.4
8-9	0.042	533	26-27	0.03	649.1
8-15	0.077	544.4	27-28	0.025	746.4
9-13	0.023	546.2	28-29	0.011	332.8
9-17	0.079	510	28-31	0.0185	244.4
10-16	0.08	454.8	28-34	0.036	489.3
11-17	0.051	399.6	29-30	0.011	270.1
12-19	0.046	414.6	29-33	0.0135	334.2
13-14	0.04	417	29-35	0.0282	160.3
13-24	0.046	518.1	30-33	0.02	270.1
14-15	0.029	649.2	31-32	0.005	285
15-25	0.076	570.6	31-34	0.0294	579.5
16-21	0.094	347.9	31-35	0.02	286.7
17-18	0.022	178.5	32-35	0.0196	288.7
17-19	0.036	278.4	33-34	0.0065	782.4
17-21	0.016	413.9	33-35	0.0198	311.5

TABLE A-II  
MAXIMUM BUS LOAD VALUES

Bus	Load (MW)	Bus	Load (MW)
1	312.9	19	621.2
2	013.8	20	618.1
3	400.3	21	408.0
4	108.9	22	1010.8
5	392.7	23	107.4
6	050.5	24	0
7	196.3	25	432.5
8	0	26	400.3
9	131.9	27	391.1
10	339.0	28	521.5
11	155.4	29	184.1
12	257.7	30	457.1
13	026.8	31	397.3
14	0	32	306.8
15	480.1	33	222.4
16	335.9	34	0
17	092.0	35	247.0
18	0		

TABLE A-III  
CONVENTIONAL GENERATION PORTFOLIO INFORMATION

Unit Type	Number of Units	Bus Locations	Avg. Fuel price (€/GJ)	Total Capacity (MW)
COAL	5	9, 34	1.75	1257
PEAT	3	11	3.71	345
BASE RENEWABLES	1	16	2.78	182
CCGT	11	8, 14, 19, 22, 23, 24, 30	5.91	5890
CHP	2	10	5.91	166
ADGT	7	1, 6, 8	6.46	735
OCCGT	14	2, 15, 21, 22, 30, 32, 34, 35	6.46	1442
PEAKERS	8	11, 25	8.33	383

## IX. REFERENCES

- [1] J.Kabouris, C.D.Vournas, "Application of Interruptible Contracts to Increase Wind Power Penetration in Congested Areas", *IEEE Transaction on Power Systems* Vol.19, No.3
- [2] D.J. Burke, M.J. O'Malley 'Maximizing Firm Wind Connection to Security Constrained Transmission Networks', *IEEE Transactions on Power Systems*, Vol.25, No.2, May 2010.
- [3] A. Lojowska, D. Kurowicka, G. Papaefthymiou and L. Van Der Sluis 'Advantages of ARMA-GARCH Wind Speed Time Series Modeling', presented at the IEEE PMAPS Conference, Singapore, June 2010.
- [4] 'European Wind Integration Study Final Report', available at <http://www.wind-integration.eu/downloads/>
- [5] 'All Island Grid Study, Workstream 4 – Analysis of Impacts and Benefits', Irish Government Department of Communications, Energy and Natural Resources/United Kingdom Department of Enterprise, Trade and Investment, Jan. 2008. Available online - <http://www.dcenr.gov.ie/Energy/North-South+Co-operation+in+the+Energy+Sector/All+Island+Electricity+Grid+Study.htm>
- [6] B. Hasche, A. Keane, M.J. O'Malley 'Capacity Value of Wind Power, Calculation and Data Requirements: the Irish Power System Case', *IEEE Transactions on Power Systems*, (Accepted, In Press).
- [7] R. Doherty, A. Mullane, G. Nolan, D. Burke, A. Bryson, M.J. O'Malley 'An Assessment of the Impact of Wind Generation on System Frequency Control', *IEEE Trans. Power Systems*, Vol.25, No.1, February 2010.
- [8] D. Gautam, V. Vittal and T. Harbour 'Impact of Increased Penetrations of DFIG Based Wind Turbine Generators on Transient and Small Signal Stability', *IEEE Transactions on Power Systems*, August 2009.
- [9] 'All-Island TSO Facilitation of Renewables WP3 Final Report', prepared for Eirgrid by Ecofys/DIgSILENT, June 2010. Available at - <http://www.eirgrid.com/media/Facilitation%20of%20Renewables%20WP3%20Final%20Report.pdf>
- [10] <http://www.nationalgrid.com/uk/Electricity/Data/>
- [11] MATLAB, available at <http://www.mathworks.com/>
- [12] General Algebraic Modeling System, GAMS – available online <http://www.gams.com/>
- [13] 'Matlab and GAMS – Interfacing Optimization and Visualization Software', by M.C. Ferris – available online at <http://www.cs.wisc.edu/math-prog/matlab.html>
- [14] C. Weber, P. Meibom, R. Barth, H. Brand, 'WILMAR: A Stochastic Programming Tool to Analyze the Large-Scale Integration of Wind Energy' Chapter-19, pp437-458, *Optimization in the Energy Industry*, Springer Berlin Heidelberg 2009.
- [15] A.Tuohy, P.Meibom, E. Denny and M.J. O'Malley 'Unit Commitment for Systems with Significant Wind Penetration', *IEEE Trans. Power Systems* Vol. 24, No. 2, May 2009.
- [16] P. Meibom, R. Barth, B. Hasche, H. Brand, C. Weber and M.J. O'Malley 'Stochastic Optimisation Model to Study the Operational Impacts of High Wind Penetrations in Ireland', *IEEE Transactions on Power Systems*, (Accepted, In Press).
- [17] D.J. Burke 'Accommodating Wind Energy Characteristics in Power Transmission Planning Applications', PhD Thesis, University College Dublin, Ireland, 2010.
- [18] A. Tuohy, M.J. O'Malley 'Impact of Pumped Storage on Power Systems with Increasing Wind Penetration', presented at the IEEE PES-GM, Calgary, Canada, July 2009.
- [19] D.J. Burke, M.J. O'Malley 'A Study of Optimal Non-Firm Wind Capacity Connection to Congested Transmission Systems', *IEEE Transactions on Sustainable Energy*, (In Review).
- [20] J.M. Morales, A.J. Conejo and J Perez-Ruiz 'Short-Term Trading for a Wind Power Producer', *IEEE Transactions on Power Systems*, Vol.25, No.1, February 2010.
- [21] C. Hiroux, M. Saguan 'Large-Scale Wind Power in European Electricity Markets – Time for Revisiting Support Schemes and Market Designs?', *Energy Policy*, 2009, doi:10.1016/j.enpol.2009.07.30
- [22] J. Wen, P. Arons, W.H. Edwin Liu 'The Role of Remedial Action Schemes in Renewable Generation Integrations', presented at the IEEE PES Innovative Smart Grid Technologies Conference, Maryland, January 2010.

## I. BIOGRAPHIES



**Daniel Burke** (M 2007) graduated from University College Cork, Ireland with a BEEE in Electrical and Electronic Engineering in 2006. He is currently conducting research for a PhD in power systems at the Electricity Research Centre in University College Dublin, Dublin, Ireland. He is a postgraduate student member of the IEEE.



**Mark O'Malley** (F'07) received B.E. and Ph. D. degrees from University College Dublin in 1983 and 1987, respectively. He is the professor of Electrical Engineering in University College Dublin and is director of the Electricity Research Centre with research interests in power systems, grid integration of renewable energy, control theory and biomedical engineering. He is a fellow of the IEEE.