



Title	Optimizing the application of plasma functionalised water (PFW) for microbial safety in fresh-cut endive processing
Authors(s)	Schnabel, Uta, Balazinski, Martina, Wagner, Robert, Bourke, Paula, et al.
Publication date	2021-08
Publication information	Schnabel, Uta, Martina Balazinski, Robert Wagner, Paula Bourke, and et al. "Optimizing the Application of Plasma Functionalised Water (PFW) for Microbial Safety in Fresh-Cut Endive Processing." Elsevier, August 2021. https://doi.org/10.1016/j.ifset.2021.102745 .
Publisher	Elsevier
Item record/more information	http://hdl.handle.net/10197/12641
Publisher's version (DOI)	10.1016/j.ifset.2021.102745

Downloaded 2026-05-01 23:46:37

The UCD community has made this article openly available. Please share how this access benefits you. Your story matters! (@ucd_oa)



© Some rights reserved. For more information

Journal Pre-proof

Optimizing the application of plasma functionalised water (PFW)
for microbial safety in fresh-cut endive processing

Uta Schnabel, Martina Balazinski, Robert Wagner, Jörg
Stachowiak, Daniela Boehm, Mathias Andrasch, Paula Bourke,
Jörg Ehlbeck



PII: S1466-8564(21)00146-6

DOI: <https://doi.org/10.1016/j.ifset.2021.102745>

Reference: INNFOO 102745

To appear in: *Innovative Food Science and Emerging Technologies*

Received date: 18 January 2021

Revised date: 17 June 2021

Accepted date: 24 June 2021

Please cite this article as: U. Schnabel, M. Balazinski, R. Wagner, et al., Optimizing the application of plasma functionalised water (PFW) for microbial safety in fresh-cut endive processing, *Innovative Food Science and Emerging Technologies* (2018), <https://doi.org/10.1016/j.ifset.2021.102745>

This is a PDF file of an article that has undergone enhancements after acceptance, such as the addition of a cover page and metadata, and formatting for readability, but it is not yet the definitive version of record. This version will undergo additional copyediting, typesetting and review before it is published in its final form, but we are providing this version to give early visibility of the article. Please note that, during the production process, errors may be discovered which could affect the content, and all legal disclaimers that apply to the journal pertain.

© 2018 © 2021 Published by Elsevier Ltd.

Optimizing the application of plasma functionalised water (PFW) for microbial safety in fresh-cut endive processing

Uta Schnabel ^{1,2,*}, Martina Balazinski ¹, Robert Wagner ¹, Jörg Stachowiak ¹, Daniela Boehm ², Mathias Andrasch ³, Paula Bourke ^{4*} and Jörg Ehlbeck ¹

¹ Leibniz Institute for Plasma Science and Technology, Greifswald, Germany

(uta.schnabel@inp-greifswald.de; martina.balazinski@inp-greifswald.de; robert.wagner@inp-greifswald.de; joerg.stachowiak@inp-greifswald.de; ehlbeck@inp-greifswald.de)

² School of Food Science and Environmental Health, Technological University Dublin, Dublin, Ireland

(D18128354@mytudublin.ie; daniela.boehm@tudublin.ie)

³ Naval School of Technology, Kramerhof OT Parow, Germany

(MathiasAndrasch@bundeswehr.org)

⁴ School of Biosystems and Food Engineering, University College Dublin, Belfield, Dublin 4, Ireland

(paula.bourke@ucd.ie)

* Correspondence: uta.schnabel@inp-greifswald.de, Felix-Hausdorff-Str. 2, 17489 Greifswald, Germany

paula.bourke@ucd.ie, University College Dublin, Belfield, Dublin 4, Ireland

Abstract: The microbiological profiles and responses of native microflora of endive were investigated using a model process line, to establish where a defined PFW should be optimally applied to retain or improve produce microbiological quality. The PFW processes were compared with tap water and ClO₂. The antimicrobial efficacy of PFW was quantified by determining the reduction in microbial load, the microbial viability and vitality. Depending on the stage of application of PFW, up to 5 log₁₀-cycles reduction was achieved, accompanied by a reduction of metabolic activity, but not necessarily with a decrease in metabolic vitality. Multiple application (3-step-PFW-application) was more effective than single application (1-step-PFW-application) and PFW showed stronger antimicrobial effect in pre-cleaned endive. High concentrations of nitrite (315 mg l⁻¹) and nitrate (472 mg l⁻¹) in PFW were the main factors for the antimicrobial efficacy of PFW against bacteria. Furthermore, H₂O₂ and an acidic pH supported the mechanism of action against the endive microflora. These results identify the pathway to scale up successful industrial application of PFW targeting microbiological quality and safety of fresh leafy products.

Industrial relevance: The safety, quality and shelf life of freshly cut vegetables, e.g. lettuce, are strongly influenced by the microbial load. In addition, the hygienic design of production line, and a good handling/ production practice are indispensable. This study shows that the application of PFW, as a promising non-thermal sanitation technology, enables the inactivation of native microbial contamination on fresh-cut endive depending on the process stage of application. It further describes the impact of PFW on the metabolic activity and metabolic vitality of the lettuce-associated microflora. For higher acceptance, the mechanism of action of PFW was assumed based on previous chemical analyses and compared to the industrial standard of ClO₂. The results contribute to the understanding and product-specificity of PFW-induced effects on safety, quality and shelf life of fresh cut lettuce and could be a basis for a possible industrial implementation and complement of common technologies.

Keywords: food safety; leafy greens; microwave-driven discharge; non-thermal processing; ready-to-eat produce

1. Introduction

As with many other vegetables, fresh-cut lettuce is a minimally processed product that is harvested, cut, washed, centrifuged and packaged (Baur et al., 2005; Odumeru et al., 1997). These activities may be associated with mechanical damage to plant tissue, which causes biochemical and physiological reactions (e.g. enzymatic browning, increased respiration and sensory and structural decay) (Saltveit, 1997). Cutting the lettuce leaves releases cell fluid that supports the growth of microorganisms. The natural microflora of fresh-cut lettuce and other vegetables is mostly characterized by Gram-negative bacteria, in particular representatives of the Pseudomonadaceae and Enterobacteriaceae (King et al., 1991), but human pathogens such as *Listeria monocytogenes*, *Salmonella* sp. or *Escherichia coli* O157:H7 are occasionally detected. Foodborne outbreaks and diseases may then be caused by these pathogens and may be associated with the consumption of raw fresh vegetables such as lettuce (Lynch, Tauxe, & Hedberg, 2009; Heaton, & Jones, 2008). Recently, the United States Department of Agriculture (USDA) and the Centers for Disease Control and Prevention (CDC) recalled lettuce products due to possible *Escherichia coli* O158:H7 contamination (CDC, 2019; USDA, 2019). Between November 2017 and January 2018 a large outbreak due to *E. coli* contaminated leafy greens in the USA and in Canada was recognized, including hospitalization and death (Food safety magazine, 2018). The European Food Safety Authority (EFSA) reported 5,146 foodborne outbreaks (including waterborne ones) for 2018 with nearly 350,000 confirmed human cases (EFSA & ECDC, 2019). Amongst others, the outbreaks were caused by *Campylobacter* (almost 70% of all reported zoonoses), *Salmonella*, Shiga toxin-producing *E. coli* (STEC infections), *Yersinia*, and *Listeria* (highest number of hospitalization and case fatality). Thermal processes to reduce or eliminate microbial risks are not applicable to fresh-cut vegetables, so non-thermal strategies are needed to reduce microbial load and ensure safety (Chen et al., 2010). Washing the fresh-cut lettuce is used to remove field heat, dirt, microorganisms, possibly pesticide residues and cell exudates (Gil et al., 2009; Zagory 1999). Washing stages are therefore particularly important for the microbial safety of fresh-cut lettuce. However, the process water can also be a source of microorganisms and lead to cross contamination. Therefore, when the use is legally permitted, water additives, mostly chemical, are used to reduce the microbial load in the washing water. Chlorine-based compounds are the most common and widely used disinfectant (Tomas-Callejas et al., 2012; Ölmez & Kretzschmar, 2009). However, the use of chemicals is not permitted in the production of organic food and in conventional food processing the use of chemical disinfectants is not without concern, as they can lead e.g. in the case of ClO_2 to the formation of potentially harmful haloform by-products (chloramines, trihalomethanes) (Copal et al., 2010). Other wash water additives or treatments already in industrial use include chemical sanitizers like ozone, hydrogen peroxide, electrolyzed water and peracetic acid, or physical treatments such as high hydrostatic pressure, pulsed electric field, oscillating magnetic field, ultra violet (UV) or gamma irradiation and high-power ultrasound (Hägele et al., 2016; Baier et al., 2014; Biazotto Bachelli, Álvares Amaral, & Benedetti, 2013; Ramos et al., 2013; Wulfkühler et al., 2013; Issa-Zacharia et al., 2010). The development of sustainable disinfection methods is important and challenging, but product quality compatibility, cost, environmental impact, and regulatory provisions must be met additionally (Matthews, 2006).

An innovative strategy demonstrated to reduce the microbial load of process water and on fresh cut produce is the use of plasma functionalised water (PFW) (Patange et al, 2019), The application of non-thermal plasma (NTP) generated at atmospheric pressure is a promising physical approach (Bourke et al., 2018; Schlüter et al., 2013). Plasmas are ionized gases containing neutral- and free charged particles such as ions and electrons (Kogelschatz, 2004). In food processing, the application of NTP in direct and remote mode is of interest, as these can be used to treat the food at low temperatures (<70 °C). In addition, processes carried out at atmospheric pressure are preferable in the food sector because they allow continuous process control and do not accelerate undesirable phase transitions, compared to applications at reduced pressure ($p < 1013$ mbar) or low pressure ($p < 10$ mbar) (Schlüter et al., 2013). PFW could be used as transport medium of reactive species and antimicrobial components for food and surface sanitation (Zhang et al., 2013). PFW is comparable to ozonized or chlorinated water with regard to the mode and stages of application as well as antimicrobial effects. The chemical composition of the PFW used within this work was previously

characterized by Schnabel et al. (2020) concerning the acidic pH, and the reactive oxygen and nitrogen species (RONS) (Schnabel et al., 2020). Both low pH and RONS are known to support and to cause the antimicrobial mechanisms of action, therefore the chemical composition of PFW should be known and controllable if PFW is to be approved as a process wash water. In the present study, PFW is investigated with respect to its antimicrobial efficacy, mechanisms of action, and its suitability as a wash water for fresh-cut lettuce. This work investigates where a PFW should be applied to optimally address the critical parameter of antimicrobial efficacy. Therefore, the PFW efficacy is determined with respect to the stage of application within a fresh cut endive processing line to ascertain where this alternative strategy is best applied for retention of microbiological quality and safety.

2. Material and methods

2.1 Plasma source PLexc²

The PLexc² plasma source is a two-stage microwave-driven device (2.45 GHz), operated at atmospheric pressure. The single stage plasma torch PLexc, which was used as the technical basis, is described in detail elsewhere (Ehlbeck et al., 2011; Krohmann, Neumann & Ehlbeck, 2005). The supply of additional microwave energy in the second plasma stage leads to a re-ignition of the effluent of the first stage to an active plasma, which processes the second gas supply. In **Figure 1** the two plasma stages are schematically illustrated. The technical parameters for the plasma device used are given in **Table 1**.

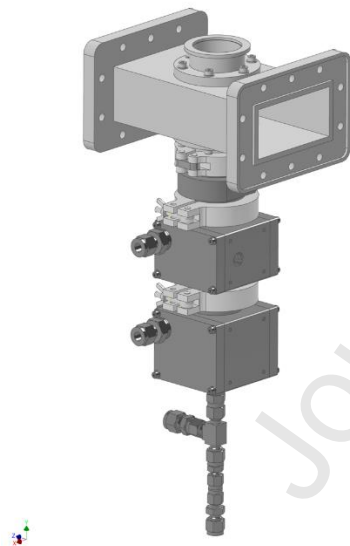

Figure 1: Schematic diagram of the microwave plasma sources PLexc².

Table 1. Technical operating parameters for the experiments.

TECHNICAL PARAMETERS

POWER (P)	4.3 kW
FREQUENCY (F)	2.45 GHz

VOLUME FLOWRATE (Γ)	72 slm
GAS	air

2.2 Generation of PFW and its chemical characterization

As described in our previous work (Schnabel et al., 2020), the plasma was used to generate plasma-processed air (PPA). Subsequently PPA was used to functionalise distilled water. This leads to the formation of PFW. In brief, the distilled water was treated with PPA in a tumbler (diameter of 700 mm) in order to have the possibility to treat from 1 l up to a maximum of 20 l of water simultaneously. Instead of distilled water, which is preferred for scientific analyses, the use of tap water is also possible (Schnabel et al., 2019).

The consistently used plasma parameters are in **Table 1**. The production rate of PFW by PPA is 60 L per hour if the water used has a pH of 7 – 8 and the applied PPA should achieve a pH < 2, which is in correlation to high RNS concentrations. The contact surface is kept stable and defined by the tumbler diameter and the rotation speed of 12 rpm with 0.44 m s^{-1} at an angle of 30° .

The chemical composition of PPA and PFW was characterized in detail by emission spectroscopy (ES, plasma fingerprint), Fourier transform infrared spectroscopy (FTIR, process gas composition), chronoamperometry (CA, hydrogen peroxide detection) (Schnabel et al., 2020; Pipa et al., 2012), and ion chromatography (IC, nitrite and nitrate detection). In the ES analysis of the microwave-induced plasma, nitrogen monoxide radical ($\cdot\text{NO}$), nitronium cation (NO_2^+) and hydroxide anion (OH^-) were detected as the main emitting species. In the FTIR analysis, the main detected components of PPA beside nitrogen (N_2) and oxygen (O_2) were nitrogen monoxide radicals ($\cdot\text{NO}$), nitrogen dioxide radicals ($\cdot\text{NO}_2$) and water (H_2O). Chronoamperometry identified H_2O_2 in the PFW. Finally, the IC measurements identified high values for NO_2^- and NO_3^- by anion separation. All measured concentrations of RONS are given in **Table 2**.

Table 2: Detected RONS concentration in PPA and PFW by FTIR, chronoamperometry and IC analysis.

RONS concentration in PPA and PFW

PPA	
$\cdot\text{NO}$	2,900 ppm ($7.79 \cdot 10^{22} \text{ m}^{-3}$)
$\cdot\text{NO}_2$	75 ppm ($2.04 \cdot 10^{21} \text{ m}^{-3}$)
H_2O	9,200 ppm ($2.47 \cdot 10^{23} \text{ m}^{-3}$)
PFW	
NO_2^-	315.83 mg l^{-1}
NO_3^-	472.8 mg l^{-1}
H_2O_2	5.61 mg l^{-1} (29.39 mM)

As the storability of PFW may play an important role for industrial application, e.g. high amounts of PFW requested in very short times, the duration of the retention of the antibacterial effect of the PFW generated using this system was investigated. The high antibacterial effects on *Pseudomonas fluorescens* ATCC 13525 were observed for 48 h minimum post generation, where the PFW was kept at 10°C (Weihe et al., 2021). Longer storage terms may be achievable by cooling or freezing (Tsoukou et al, 2020) but this is also likely dependent on specific chemistry and should be confirmed for this PFW formulation.

2.3 Processing of fresh-cut endive

The endive (*Cichorium endivia* L.) was bought at a local organic market in Greifswald, Germany. Subsequently, the whole endive heads were stored for a maximum of 24 h at 7 ± 0.1 °C, and cut directly before experimental use. The outermost leaves were removed, but the stalk was retained. Both, the softer leaf parts and the harder stalk parts of the lettuce were mixed to provide representative samples. The processing of the fresh-cut endive was performed on a washing line mimicking a common industrial production process. To test different process variants, the washing line ultimately consisted of up to five main sections – pre-bathing, pre-rinsing, pre-washing, main washing and post-rinsing. The investigated process variants are given in **Table 3** and as an example, the reference with tap water is illustrated in **Figure 2**. After the last washing step, the samples were briefly stored over a sieve for draining, but were not spun.

Table 3. The investigated process variants and the stage of application of PFW in a model process line. NA is used for “not analysed”. Colours are used for better visualization.

<i>Process variant</i>	<i>Unwashed (0)</i>	<i>Pre-bathing (1)</i>	<i>Pre-rinsing (2)</i>	<i>Pre-washing (3)</i>	<i>Main washing (4)</i>	<i>Post-rinsing (5)</i>
Duration of washing [s]	0	180	30	180	180	30
tap-water (A)	NA	water/NA	water	water	water	water
PFW (B)	NA	PFW	water	water	water	water
PFW (C)	NA	NA	PFW	water	water	water
PFW (D)	NA	NA	water	water	PFW	water
PFW (E)	NA	PFW	PFW	water	PFW	water
ClO ₂ (F)	NA	NA	water	water	ClO ₂	water

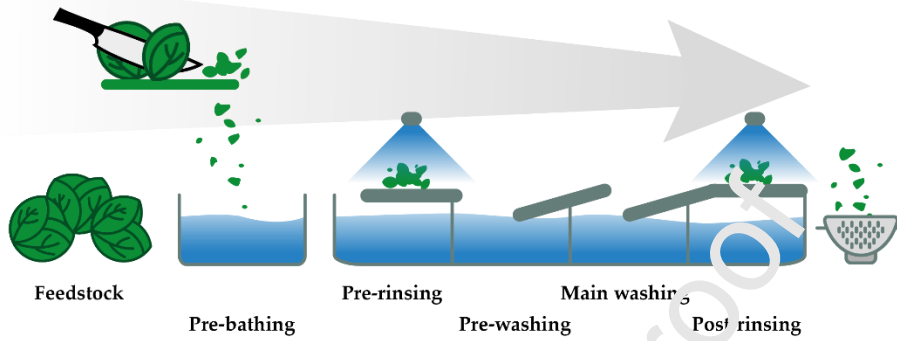

Figure 2: The model process line employed for tap water process variant (adapted from Schnabel et al., 2021).

2.4 Characterizing the antimicrobial efficacy and mechanisms of PFW

2.4.1 Antimicrobial efficacy (CFU-assay)

To determine the natural contamination on the fresh-cut endives before and after treatment, the samples were homogenized in bags with 10 ml homogenizer solution (0.85% NaCl, 10% Tween80 and 10 mg l⁻¹ sodium thiosulfate, all chemicals from Carl Roth GmbH + Co. KG, Karlsruhe, Germany) for 30 s at a speed of 400 rpm. This suspension was used to prepare a decimal dilution series in maximum recovery diluent (MRD). Volumes of 100µl aliquot were used for surface-spread-plate counts using Plate Count Agar (Roth GmbH, Karlsruhe, Germany), and plates were incubated for 24 hours at 30 °C under aerobic conditions. The detection limit of this method was 10 cfu·ml⁻¹.

2.4.1.1 Calculation of reduction factor and standard deviation of reduction factor

For fresh-cut lettuce specimens the reduction (R) and reduction factor (RF) were calculated as follows:

$$R = \frac{n_{MO}^{Ref}}{n_{MO}^{Sam}} \quad (1)$$

n_{MO}^{Ref} : concentration of microorganism of the reference

n_{MO}^{Sam} : concentration of microorganism of the treated sample

$$RF = \log_{10}(R) \quad (2)$$

The standard deviation of the reduction (ΔR) was calculated as follows:

$$\Delta R = \sqrt{\left(\frac{\partial R}{\partial n_{MO}^{Ref}} \cdot \Delta n_{MO}^{Ref}\right)^2 + \left(\frac{\partial R}{\partial n_{MO}^{Sam}} \cdot \Delta n_{MO}^{Sam}(i)\right)^2} \quad (3)$$

$$\frac{\partial R}{\partial n_{MO}^{Ref}} = \frac{1}{n_{MO}^{Sam}(i)} \quad (4)$$

$$\frac{\partial R}{\partial n_{MO}^{Sam}} = -\frac{n_{MO}^{Ref}}{n_{MO}^{Sam}(i)^2} \quad (5)$$

$$\Delta R = \sqrt{\left(\frac{1}{n_{MO}^{Sam}(i)} \cdot \Delta n_{MO}^{Ref}\right)^2 + \left(\frac{n_{MO}^{Ref}}{n_{MO}^{Sam}(i)^2} \cdot \Delta n_{MO}^{Sam}(i)\right)^2} \quad (6)$$

Δn_{MO}^{Ref} : error of reference

$\Delta n_{MO}^{Sam}(i)$: error of sample i

ΔR : error of reduction

2.4.2 Metabolic activity (XTT-assay)

The XTT assay was used to determine cell viability before and after treatment (AppliChem, St. Louis, USA) according to manufacturer instructions. This assay demonstrates cell viability as a function of the redox potential resulting from electron transport through the transplasmic membrane (Scudiero et al., 1988). The sample was the same suspension that was used for the CFU- and the fluorescence-assay. The 96-well plate was incubated at 37 °C with continuous horizontal shaking (80 rpm) overnight (16-20 h) in the dark. The 96-well plate was then scanned at a wavelength of 470 nm using the Varioskan Flash® device (Fisher Scientific GmbH, Schwerte, Germany). The values obtained were blank corrected with XTT and activation solution mixture without sample, scanned at a wavelength of 470 nm. The experiments were repeated three times with $n=3$, resulting in $n=9$.

2.4.3 Vitality (Fluorescence-assay)

The LIVE/DEAD BacLight™ Bacterial Viability Kit (Fisher Scientific GmbH, Schwerte, Germany) was used according to the manufacturer instructions. Briefly, 0.9 µl of the dye mixture was added to 300 µl of the suspension, and then placed on a rotary shaker in the dark at room temperature for 20 min. Using a fluorescence microplate reader (Varioskan-Flash®, Fisher Scientific GmbH, Schwerte, Germany) the fluorescence of each well of a 96-well plate was determined using an excitation wavelength of 470 nm and an emission wavelength of 530 nm and 630 nm for green (G) and red (R) fluorescence respectively. A G/R ratio was then calculated by dividing the intensity value of the green fluorescence by the value of the red fluorescence. The experiments were repeated three times with $n=3$, resulting in $n=9$.

2.5 Nitrite and nitrate concentration in the washing water analysed by IC measurements

At each step, where PFW was applied, it was freshly prepared, used and not reused. To determine the nitrite and nitrate concentration in the washing water (tap water and PFW) before and after fresh-cut lettuce application, ion chromatography measurements were done.

Measurements were carried out using a Dionex ICS 6000 system (Thermo Scientific, Dreieich, Germany) with a conductivity detector. The system was controlled by Dionex Chromeleon Version 7.1.3.1541. Separation of the ions was performed via an anion-exchange column (Dionex IonPac AS 18, Thermo Scientific, Dreieich, Germany) with a guard column (Dionex IonPac AG 18, Thermo Scientific, Dreieich, Germany). Ultrapure water (GenPure Pro Barnstead, Thermo Fisher Scientific, Dreieich, Germany) in combination with a 23 mM KOH cartridge (Thermo Scientific, Dreieich, Germany) was used as the eluent.

Injection of samples was realized by a partial loop injection method with a volume of 5 µl. Each sample was diluted 1:25, except the tap water reference which was diluted 1:10. The runtime for each

measurement was 20 minutes with an eluent flow of 0.25 ml min⁻¹. Samples were stored in the autosampler at 10 °C (± 5 °C). The experiments were repeated three times with n=3, resulting in n=9.

The identification and quantification was based on the Dionex 7-ion standard solution (Thermo Scientific, Dreieich, Germany), diluted with ultrapure water in samples of 1:1, 1:2, 1:4, 1:8, 1:16, 1:32, 1:64 and 1:128. The concentrations of nitrite and nitrate were calculated by the usage of the linear regression function of the measured standards (7).

$$c = \frac{(AUC \pm y_{intercept})}{x_{slope}} \quad (7)$$

Where AUC is the integrated area under the conductivity peak over the retention time of the detected anion, x_{slope} is the slope of the regression function and $y_{intercept}$ is the interception of the y-axis of the regression function.

In these experiments only the process variants A and E (**Table 3**) were examined, to provide insight of the possible depletion of antimicrobial RNS – nitrite and nitrate – by interaction with the fresh-cut lettuce at the specific washing steps.

3. Results

3.1 Antimicrobial efficacy

In **Figure 3** the reduction factor (RF) by which the population density is reduced, has been quantified. The RF is the number of log₁₀-cycles that the microbial population declines. Washing fresh-cut endive with tap water provided a reduction of nearly 2 log₁₀-cycles (**Figure 3a** to **3e**, black triangles; **Table 3**, variant A). When fresh-cut endive was washed with PFW, the dynamic of the inactivation curves changed. In variant B (**Figure 3a**, red dots), when PFW was used at the first extraction point, the RF was greater than 2 and remained above this value until the last extraction point, even though the lettuce was washed with tap water from then onwards. The survival of the native microflora of the lettuce was negatively affected by the PFW.

Figure 3b shows the results for variant C. Here, PFW was used at the second extraction point (pre-rinsing), and again, the RF was above 2. However, the RF declined faster than in variant B (**Figure 3a**) to a value close to 1 in the following washing stages, which may be due to the shorter treatment time of 30 s with PFW and to the pre-rinsing stage of application instead of pre-bathing. There was a significantly different kinetic in response to PFW application at the fourth washing stage (main washing) presented as process variant D (**Figure 3c**), where the RF increased to more than 3 and decreased only slightly below 3 at the post-rinsing washing stage. This significantly higher RF achieved for variant D (**Figure 3c**) compared to variants B (**Figure 3a**) and C (**Figure 3b**) could be explained by the use of the washing stages 2 and 3 prior to the application of the antimicrobial PFW. Washing stages 2 and 3 may clean and loosen dirt particles, which then no longer interfere with the mechanism of the antimicrobial substances present in the PFW. In variant E (**Figure 3d**), PFW was used across washing stages 1, 2 and 4, which led to very high reductions between 4 and 5 log₁₀ cycles. The antimicrobial effect of ClO₂ with a concentration of 15 ppm and when applied at washing stage 4 as per industrial practice, (**Figure 3e**, variant F) showed a reduction comparable with tap water.

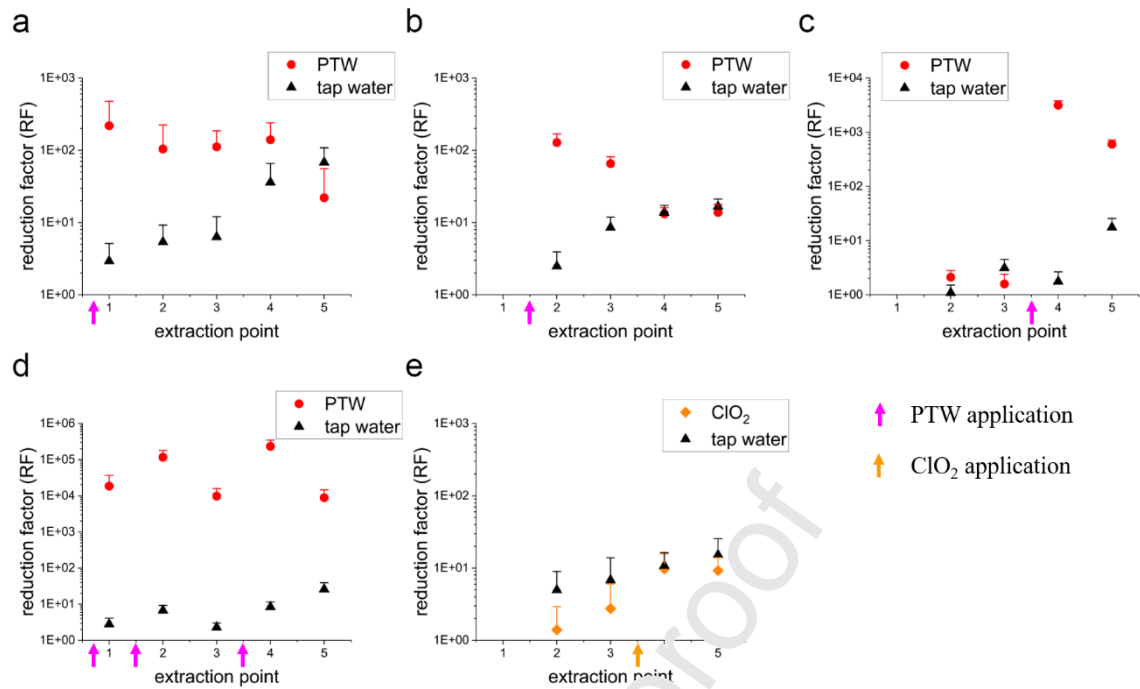

Figure 3: Antimicrobial efficacy – reduction factor - of the process variants applied. All RFs are related to the unwashed lettuce as the reference point. a) In red – variant B: PFW at extraction point 1 (180 s pre-bathing), extraction points 2 to 5 with tap water; in black – tap water used at extraction points 1 to 5. b) In red – variant C: PFW at extraction point 2 (30 s pre-rinsing), extraction points 3 to 5 with tap water; in black – tap water used at extraction points 2 to 5. c) In red – variant D: PFW at extraction point 4 (180 s main washing), extraction points 2, 3 and 5 with tap water; in black – tap water used at extraction points 2 to 5. d) In red – variant E: PFW at extraction point 1, 2 and 4 (180 s pre-bathing, 30 s pre-rinsing, 180 s main washing), extraction points 3 and 5 with tap water; in black – tap water used at extraction points 1 to 5. e) In orange – variant F: ClO₂ at concentration of 15 ppm at extraction point 4 (180 s main washing), extraction points 2, 3 and 5 with tap water; in black – tap water used at extraction points 2 to 5. The initial concentration was 10⁶ to 10⁷cfu g⁻¹. All experiments were repeated threefold with r =3 resulting in n=9.

3.2 Metabolic activity

The results of the XTT assay, which assesses the cell viability as a function of the redox potential, are presented in **Figure 4**.

The absorption of formazan dye at 470 nm is given as a percentage of the reference (extraction point 0 (unwashed) in **Table 3**) over the extraction points for the washing process variants. Metabolically active cells can reduce the tetrazolium salt XTT to the orange colored compound formazan. The higher the percentage, the higher the metabolic activity retained in the membranes of the microbial cells obtained from the lettuce. The data for the extraction point 0 showed the metabolic activity for the unwashed lettuce as 100%. Introducing PFW at the different stages within process variants B, C and F (**Figure 4a, 4b and 4e**) had no difference in the effect on the metabolic activity by comparison with that recorded for tap water, PFW or ClO₂ treatments of washed fresh-cut lettuce at all extraction points. However, using PFW at the main washing step - variant D (**Figure 4c**) affected the metabolic activity of the microorganisms, demonstrated by the decrease to 40% metabolic activity at extraction points 4 and 5 in variant D. Variant E (**Figure 4d**) where PFW

was used at three process stages, showed an extremely steep decrease in the metabolic cell activity to approx. 3% for all extraction points.

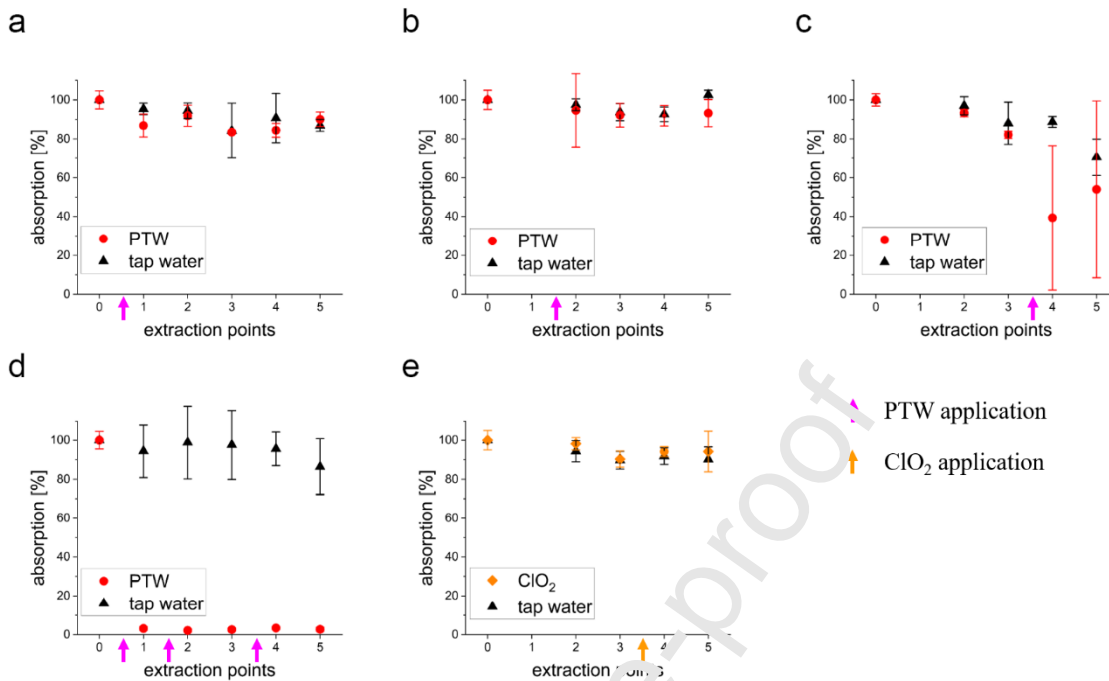

Figure 4: The effect of process variant on the metabolic activity using the XTT assay. All data points are related to the unwashed lettuce (reference, extraction point 0). a) In red – variant B: PFW at extraction point 1 (180 s pre-bathing), extraction points 2 to 5 with tap water; in black – tap water (variant A) used at extraction points 1 to 5. b) In red – variant C: PFW at extraction point 2 (30 s pre-rinsing), extraction points 3 to 5 with tap water; in black – tap water used at extraction points 2 to 5. c) In red – variant D: PFW at extraction point 4 (180 s main washing), extraction points 2, 3 and 5 with tap water; in black – tap water used at extraction points 2 to 5. d) In red – variant E: PFW at extraction point 1, 2 and 4 (180 s pre-bathing, 30 s pre-rinsing, 180 s main washing), extraction points 3 and 5 with tap water; in black – tap water used at extraction points 1 to 5. e) In orange – variant : ClO₂ at concentration of 15 ppm at extraction point 4 (180 s main washing), extraction points 2, 3 and 5 with tap water; in black – tap water used at extraction points 2 to 5. All experiments were repeated threefold with n=3 resulting in n=9.

3.3 Vitality assay

With regard to the effect of the stage of application of PFW on microbial vitality, in most of the process variants, there was no difference observed between the cell envelope of microorganisms washed with tap water, PFW or ClO₂ (**Figure 5**).

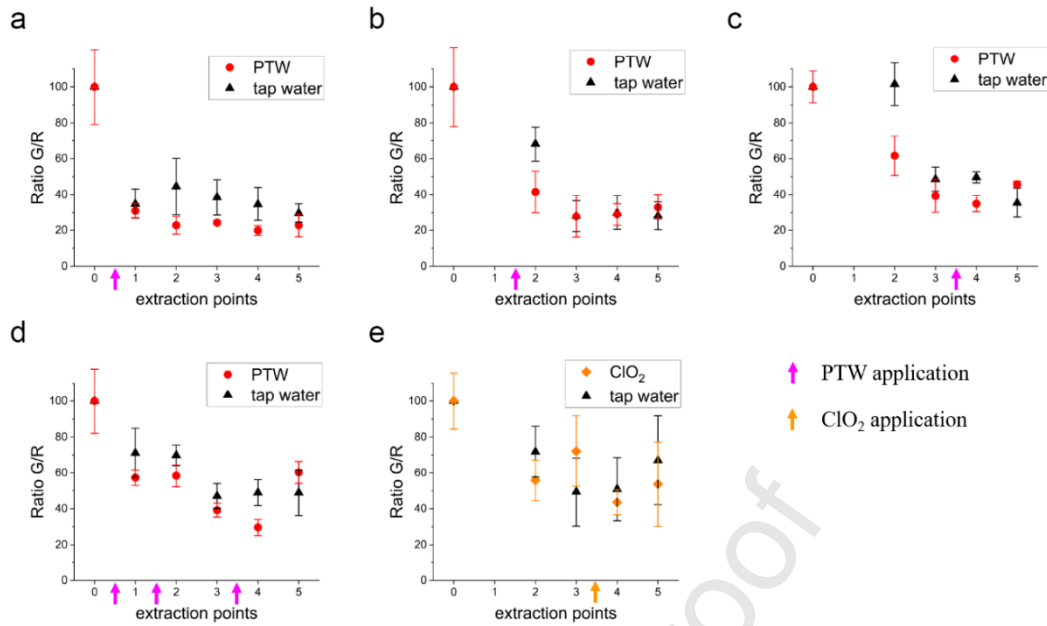

Figure 5: The effect of PFW unit processes on the microbial vitality of the native microflora of the endive. All data points are related to the unwashed lettuce (reference, extraction point 0). a) In red – variant B: PFW at extraction point 1 (180 s pre-bathing), extraction points 2 to 5 with tap water; in black – tap water (variant A) used at extraction points 1 to 5. b) In red – variant C: PFW at extraction point 2 (30 s pre-rinsing), extraction points 3 to 5 with tap water; in black – tap water used at extraction points 2 to 5. c) In red – variant D: PFW at extraction point 4 (180 s main washing), extraction points 2, 3 and 5 with tap water; in black – tap water used at extraction points 2 to 5. d) In red – variant E: PFW at extraction points 1, 2 and 4 (180 s pre-bathing, 30 s pre-rinsing, 180 s main washing), extraction points 3 and 5 with tap water; in black – tap water used at extraction points 1 to 5. e) In orange – variant F: ClO_2 at concentration of 15 ppm at extraction point 4 (180 s main washing), extraction points 2, 3 and 5 with tap water; in black – tap water used at extraction points 2 to 5. All experiments were repeated threefold with $n=3$ resulting in $n=9$.

The results obtained showed less differences than those observed for the antimicrobial activity (CFU, **Figure 3**) and metabolic activity (XTT, **Figure 4**). For variants B, C and F (**Figure 5a, 5b and 5e**), the data points lead to the conclusion that the cell membrane was severely damaged. However, for each of these variants, a normal metabolic activity was detected in the XTT assay and in the proliferation assay (CFU); only a reduction of 1 to 2 \log_{10} -cycles was detected for the same data points.

In contrast, there was a very high reduction of 3 to 5 \log_{10} -cycles for the variants D and E (**Figure 3c and 3d**) in the proliferation assay and a strong reduction of metabolic activity (**Figure 4c and 4d**) was shown. However, the vitality of remaining populations showed small differences (**Figure 5c and 5d**) to the variants B, C and F (**Figure 5a, 5b and 5e**), as well as for tap water.

3.4 Nitrite and nitrate concentration in the washing water (tap water or PFW) before and after application

Table 4 depicts the average nitrite and nitrate concentrations at each extraction point for process variant A and E (**Table 3**). All extractions from process variant A contained detectable nitrate, but nitrite was undetectable. This was expected as only tap water was used for washing and the tap water reference also showed only nitrate anions. However, an increase in the nitrate concentrations in for all extraction points from process variant A was seen compared with the tap water reference. This may be caused by the leaching of nitrate of the fresh-cut washed lettuce.

Regarding process variant E, the nitrate concentrations for the pre-bathing, pre-rinsing and main washing are within the standard deviation of the PFW reference; no significant influence of the lettuce itself is noted. For the pre-washing and post-rinsing of process variant E an increase of the nitrate and nitrite concentration in contrast to the tap water reference was recorded. These increases are most likely caused by carry-over effects of the prior PFW-washing-step, since these steps contained PFW with higher nitrite and nitrate concentrations.

Table 4 The average concentrations of nitrite and nitrate in mg/l of each extraction point detected via IC. ND is used for "not detected".

Process variant	Extraction point	c_{NO_2} [ng/l]	c_{NO_3} [mg/l]
A	Pre-bathing	ND	71.1996 (± 1.9342)
	Pre-rinsing	ND	69.7848 (± 2.8053)
	Pre-washing	ND	70.4478 (± 0.5705)
	Main washing	ND	72.9161 (± 5.2735)
	Post-rinsing	ND	68.5368 (± 2.9195)
E	Pre-bathing	241.1622 (± 72.9661)	466.3155 (± 27.5796)
	Pre-rinsing	160.3129 (± 50.0431)	482.6958 (± 24.3364)
	Pre-washing	15.8799 (± 4.6234)	123.9002 (± 3.7866)
	Main washing	218.2333 (± 57.6505)	420.7843 (± 19.0138)
	Post-rinsing	43.4312 (± 7.4343)	161.8436 (± 24.2576)
Reference (100 % tap water)		ND	58.9111 (± 3.1769)
Reference (100 % PFW)		315.8344 (± 95.0439)	472.8019 (± 34.6399)

4. Discussion

This study sought to compare PFW with standard washing treatments for fresh cut produce, and also to determine at which stage or stages in the washing process PFW can be optimally used to maximise effects prior to packaging. A comparison of the application of PFW, i.e. whether it is nebulized in the pre-rinsing stage (variant C) or as a bath in the pre- and main washing stages (variants B and E), shows that the higher wetting of the lettuce surface during bathing is advantageous compared to the lower wetting during rinsing. However, the exposure time during rinsing was also significantly lower due to the experimental setup. In a comparison of variants B and D (washing with PFW, same exposure time), it can be concluded that a pre-cleaned lettuce washed with tap water (variant D) allows a better antimicrobial effect of PFW than if the fresh-cut lettuce is still contaminated (variant B). If PFW is used multiple times in the washing process (variant E), the antimicrobial effect is increased compared to a single application (variants B, C, D) and the reduction achieved is retained at this very high level up to the final product. In addition, the multiple or late use of PFW in the washing process (variants D and E) not only had an effect on the reduction of the total bacterial count, but also on the metabolism and the vitality of the microorganisms remaining on the lettuce. This can have a positive effect on the shelf life of the fresh-cut lettuce. Our analyses show how and where PFW can be optimally applied in the washing process of fresh-cut lettuce, depending on industrial conditions. However, challenging the optimized protocols for reduction of representative pathogens and their subsequent behaviour over extended storage life is required. The composition of PPA influences the chemical characteristic of PFW and thus its antimicrobial properties. Knowing the chemical composition of PPA and PFW allows conclusions to be drawn about the antimicrobial effect of PFW as a process water against produce contaminants and where PFW may be optimal. The chemical analyses of PFW (Schnabel et al., 2020) showed a strong acidification, which can support important antimicrobial chemical reactions in bacterial cells. The main compounds detected in PFW were NO_2^- and NO_3^- (Schnabel et al., 2020), and the antimicrobial properties of high concentrations of NO_2^- and NO_3^- in an acidic environment are well described in literature (Oehmigen et al., 2011; Naitali et al., 2010). The inhibition of the antioxidant pathways, the damage of membrane protein repair cascades and DNA repair cascades by reactive nitrogen and oxygen species (RONS) may lead to microbial inactivation (Vatansever et al., 2013; Pomposiello & Demple, 2002). High concentrations of NO_2^- in combination with H_2O_2 play a key role in the microbial inactivation by PFW (Shaw et al., 2010; Shen et al., 2016). Both chemicals can form peroxyntitric acid (O_2NOOH), which subsequently leads to the formation of superoxide ($\text{O}_2^{\cdot-}$) (Ikawa et al., 2016; Arts, Gennaris & Collet, 2013). $\text{O}_2^{\cdot-}$ is among other ROS significant for bacterial inactivation ([27,41]. ONOO^- , which can be produced by H_2O_2 and nitrous acid (HNO_2), is also responsible for the inactivation of microorganisms (Lukes et al., 2014). However, this molecule was not detected in the PFW. Chemical reactions of RONS are very complex in PFW (Traylor et al., 2011). Microorganisms, especially under aerobic conditions, can survive oxidative and nitrosative stresses. The cell wall and membranes of bacteria are the first protection barrier from the extracellular environment; therefore, they have many repair mechanisms to maintain their cell integrity. Bacteria produce RONS as natural byproducts during their metabolic activity (Vatansever et al., 2013), therefore, microorganisms have defense mechanisms like superoxide dismutase (SOD) and catalase, which convert $\text{O}_2^{\cdot-}$ to H_2O_2 and H_2O_2 to H_2O and O_2 . Furthermore, the presence of nitrate reductases, allows bacteria to utilize NO_3^- as a nitrogen source or use NO_3^- as an alternative electron acceptor during ATP synthesis (Moreno-Vivián et al., 1999).

H_2O_2 was also detected in this PFW, but at a very low concentration of 5.61 mg l^{-1} (29.39 mM) (Schnabel et al., 2020). Commonly, a 3% (882 mM) to 6% (1,764 mM) solution is used (Linley et al., 2012). H_2O_2 has a strong antimicrobial effect at high concentrations, but needs long exposure times at lower concentrations. While the structure of the bacterial cell wall makes Gram-positive bacteria more susceptible than Gram-negative ones, Gram-positive bacteria have catalase and peroxidase proteins to increase their tolerance against H_2O_2 at lower concentrations (McDonnell & Russell, 1999). Anaerobic microorganisms are more sensitive than aerobic ones and yeast and molds are in most cases more resistant to H_2O_2 than bacteria (Block 2001). To realize the antimicrobial effect of H_2O_2 ,

the treatment environment should be at low pH as an alkaline environment would decompose H_2O_2 rapidly (Wallhäußer 1995). H_2O_2 is known to produce hydroxyl radicals ($\cdot\text{OH}$). The strong oxidizing potential of H_2O_2 can lead to the destruction of cell components like oxidation-sensitive metabolic enzymes. Subsequently, this may be followed by oxidation of structural elements with sulfhydryl groups or disulfide bridges. As a result, these structures lose their functionality and the cell metabolism collapses.

The cell envelope is exposed to the oxidizing molecules, based on the plasma reactive species, which target the microorganisms. Elevated levels of reactive species can lead to intracellular damage to DNA, proteins as well as membrane lipids leading finally to cell death. Therefore, the presence of oxidative stress defense mechanisms is crucial for cell survival. Thus, bacteria, like nearly all other living organisms, contain enzymatic systems to deal with oxidative stress. These defense mechanisms occur in bacteria in the cytoplasm and the cell membranes. The cell envelope of bacteria consists of membranes, a cell wall made of peptidoglycan and the periplasmic space. Gram-negative bacteria have an outer and an inner membrane with a thin layer of peptidoglycan whereas Gram-positive bacteria have only one inner membrane but a thick peptidoglycan cell wall. Active $\text{O}_2^{\cdot-}$ cannot easily penetrate cell membranes (Arts, Gennaris & Collet 2011). Therefore, SODs are active in the cytoplasm and periplasm to detoxify $\text{O}_2^{\cdot-}$ such as released by the respiratory systems. Commonly, the SODs are synthesized at stationary phase. In contrast, H_2O_2 diffuses through biological membranes and is detoxified in the bacterial cytoplasm by catalases and peroxidases. Up to now, only one enzyme in the periplasm for peroxide reduction has been reported in the literature (Cho et al., 2012). The defense mechanism of bacteria against oxidative stress deals with two options: 1) direct inactivation of RONS and 2) protein repair after oxidative damage. Thus, minimal membrane defects do not lead to cell death.

The proposed mechanisms of action of PFW against Gram-negative and Gram-positive bacteria are based on the results for the chemistry of PFW and the CFU, XTT and LIVE/DEAD assays for possible and identified ROS in **Figure 6** and in **Figure 7** for possible and identified RNS.

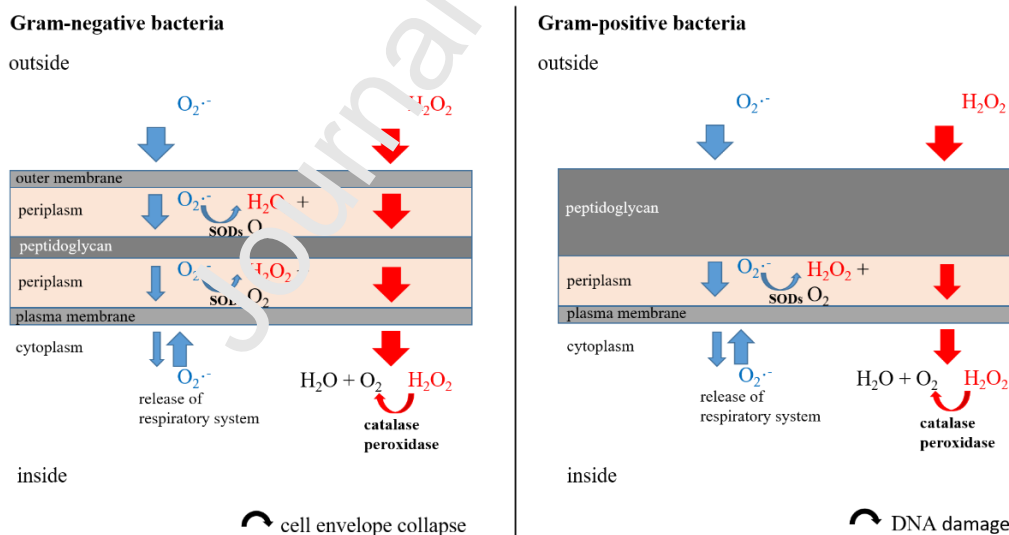

Figure 6: Proposed mechanism of action of PFW based on reactive oxygen species (ROS). Adapted from (Han et al., 2016).

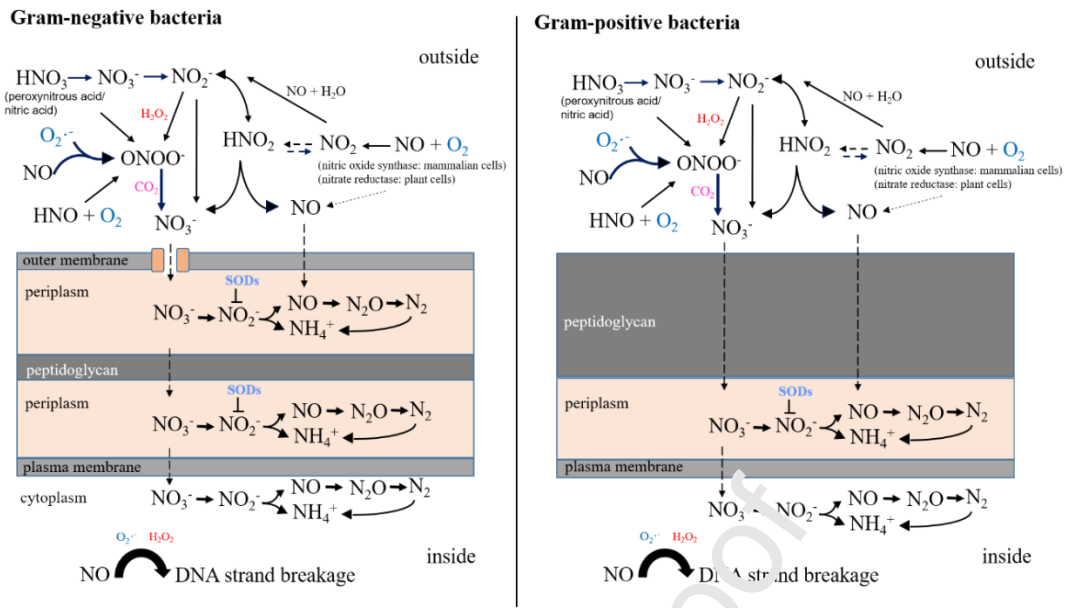

Figure 7: Proposed mechanism of action of PFW based on reactive nitrogen species (RNS).

Reactions are dependent on pH and the availability of oxygen. Arranged after (Torres et al., 2016; Vázquez-Torres & Bäumlér, 2016; Shiva, 2013; Biology of the Nitrogen Cycle, 2007; Cammack et al., 1999; Chan et al., 1992; Shank, Silliker & Harper, 1992)

As the total native load of the fresh-cut lettuce was investigated in this study, a distinction between Gram-positive and Gram-negative bacteria was not possible. Based on the proposed mechanism of action by (Han et al., 2016) and the observed higher tolerance of Gram-positive bacteria compared to Gram-negative ones (Pericone et al., 2000) additional investigations are needed concerning the microbial diversity of the native load (e.g. selective agar) and the possible inactivation outcomes (e.g. cell leakage, DNA damage). The prevalent microbial populations are modified on fresh produce as a function of preparation, processing treatments, storage conditions, temperature and time. Gram-negative psychrophiles and psychrotolerant populations are predominant spoilers of produce in refrigerated storage, although some Gram-positive populations such as lactic acid bacteria can also persist. Gram-negative bacteria seem to be more tolerant against $O_2^{\cdot-}$ due to more periplasmic space with SODs, and less tolerant against H_2O_2 due to less peptidoglycan compared to Gram-positive bacteria. Gram-positive bacteria seem to be more tolerant against H_2O_2 and more sensitive to $O_2^{\cdot-}$.

Since Gram-negative bacteria have a different cell wall structure than Gram-positive bacteria, the RNS present in the PFW may influence the respective mechanism of inactivation. For example, the NO_3^- in PFW can penetrate directly through the porins in the cell wall of Gram-negative bacteria, whereas in Gram-positive bacteria it diffuses through the thick peptidoglycan layer (Figure 7). Thus, the NO_3^- concentration in the periplasmic space could be increased in different ways, thereby delaying the activation of bacterial defense mechanisms. Since Gram-negative bacteria have a larger periplasm in which many degradation processes of NO_3^- can take place by different reductases (nitrate reductase, nitrite reductase, nitric oxide reductase, nitrous oxide reductase and nitrogenase), it is conceivable that Gram-negative bacteria defenses react more effectively to the antimicrobial effect of this PFW.

There was also an overlap with the ROS mechanisms (Figure 6), since SODs not only degrade $O_2^{\cdot-}$ to H_2O_2 but can also inhibit the formation of NO_2^- in the periplasm (Figure 7) and thus prevent further degradation by nitrite reductase to NO or NH_4^+ . This allows more NO_3^- to enter the cytoplasm, where it can then react via NO_2^- to NO. In combination with $O_2^{\cdot-}$ and H_2O_2 the latter can lead to DNA strand breaks and thus to cell death. All antimicrobial RONS (NO_3^- , NO_2^- and H_2O_2) detected in the PFW interact with each other and can support each other in their effect, just as the

low pH < 2 promotes the antimicrobial effect. Since O_2^- also plays an important theoretical role, the persistence and concentration in this PFW should be established.

Considering the collated results, an inactivation of the natural load on fresh-cut lettuce is possible. The success of PFW in fresh produce processing is clearly a function of the stage of application, and also the PFW volume to product ratio, the means of the application (rinsing or washing), and treatment time duration (contact time). However, PFW alone is likely to cause only minor cell membrane damage, whereas metabolic activity could be significantly affected. Chlorine dioxide at a concentration of 15 ppm (15 mg l⁻¹) used for 180 s caused comparable effects to tap water. Here 15 ppm represents a higher concentration than is usually used for industrial washing of lettuce with 3 mg l⁻¹ for 30 – 300 s (FAO & WHO, 2009).

For industry application, up-scaling of the device and/or its mode of operation would be necessary to align with industry scale processor needs. However, the scalability of bench or pilot scale devices in the sense of pure size adjustment is mostly insufficient for industrial application.

Bench scale trials are set up to explore key parameters and provide a "proof of principle" under laboratory conditions. Therefore, questions of scalability and efficiency can play a subordinate role, but these questions should be the focus of implementation on a pilot and industrial scale.

In addition to expanding the capacity of the used system, the efficiency of the individual process steps, their reliable technical implementation and an operating concept that allows the circle of operators to be trained to include non-scientific personnel must also be carried out. Furthermore, safety, occupational health and safety and life cycle environmental aspects must be integrated into the overall concept to a completely different extent when operating complex systems on a pilot or industrial scale and with the associated increased substance turnover.

Based on pilot scale experiments described by Schnabel et al. (2019) the applied technique has already demonstrated scalability. The capacity of the current pilot set up generates 60 l h⁻¹ PFW (with pH < 2.0) per module with costs of about 1 Euro ct l⁻¹ (related to actual German energy costs). Therefore, application to an industrial scale of 400 kg lettuce per hour is a realistic prospect.

An identified problem of the pilot scale setup was the process efficacy. Therefore, in the present study, the focus was placed on realising process effectiveness, in order to use the PFW generated as efficiently as possible. For this purpose, the laboratory system consisted of several process treatment stations, which were built on the basis of the pilot scale system in Schnabel et al. (2019), but offered the flexibility to change conditions for comparing different treatment scenarios. Future steps include the adaptation of these processing parameters to an industrial scale set-up under real industrial processing conditions.

5. Conclusions

The present study demonstrated that PFW, when introduced at the correct process stage(s) represents an effective process water to improve conventional washing methods for fresh-cut produce. PFW exhibited strong antimicrobial activity against endive-associated microorganisms from 1 to 5 log₁₀-cycles. The antimicrobial active agents quantified in PFW included H₂O₂, NO₂⁻ and NO₃⁻ the acidification to low pH values. The promising results and the advantages of this PFW including low-temperature application, simple and cheap generation based on air and water and enhanced efficacy by comparison with current procedures such as tap water rinsing and chlorinated water, offers a timely and sustainable strategy for fresh produce microbiological quality retention.

Author Contributions: Conceptualization, U.S. and P.B.; methodology, U.S., M.B., R.W., J.S., M.A.; investigation, U.S., M.B., R.W., J.S. writing—original draft preparation, U.S.; writing—review and editing, D.B., P.B. and J.E.; supervision, D.B., P.B. and J.E.; project administration, J.E.; funding acquisition, J.E. All authors have read and agreed to the published version of the manuscript.

Funding: This research was partly funded by the Federal Ministry for Food and Agriculture (BMEL) of Germany, grant number 2816IP005 and by the Federal Office for Agriculture and Food (ptBLE) within the program "Deutsche Innovationspartnerschaft Agrar" (DIP), through SFI grant number SFI/16/BBSRC/3391 and through the FIRM program (17/F/275), administered by Department of Agriculture, Food and Marine, Ireland

Acknowledgments: The authors like to thank Carsten Desjardin for assistance with visualization of figures, graphs and tables.

Conflicts of Interest: The authors declare no conflict of interest.

References

- Arts, I. S., Gennaris, A., & Collet, J. F. (2015). Reducing systems protecting the bacterial cell envelope from oxidative damage. *FEBS Letters*, *589*, 1559–1568. DOI: <https://doi.org/10.1016/j.febslet.2015.04.057>
- Baier, M., Görgen, M., Ehlbeck, J., Knorr, D., Herppich, W. B., & Schlüter, O. (2014). Non-thermal atmospheric pressure plasma: Screening for gentle process conditions and antibacterial efficiency on perishable fresh produce. *Innovative Food Science and Emerging Technologies*, *22*, 147–157. DOI: <https://doi.org/10.1016/j.ifset.2014.01.011>.
- Baur, S., Klaiber, R., Wei, H., Hammes, W. P., & Carle, R. (2005). Effect of temperature and chlorination of pre-washing water on shelf-life and physiological properties of ready-to-use iceberg lettuce. *Innovative Food Science and Emerging Technologies*, *6*, 171 - 182. DOI: [10.1016/j.ifset.2005.02.002](https://doi.org/10.1016/j.ifset.2005.02.002).
- Biazotto Bachelli, M. L., Álvares Amaral, R. D., & Benedetti, B. C. (2013). Alternative sanitization methods for minimally processed lettuce in comparison to sodium hypochlorite. *Brazilian Journal of Microbiology*, *44*, 673-678. DOI: [10.1590/s1517-8352013005000065](https://doi.org/10.1590/s1517-8352013005000065).
- Biology of the Nitrogen Cycle. 1st ed., Editors: Bothe, H.; Ferguson, S.J.; Newton, W.E.; Elsevier, 2007, Amsterdam, the Netherlands.
- Block, S. S. (2001). Peroxygen Compounds. In: Block, S.S. (Ed.): Disinfection, Sterilization and Preservation. Philadelphia: Lea & Febiger. pp.185-204.
- Bourke, P., Ziuzina, D., Boehm, D., Culbert, P. J., & Keener, K. (2018). The Potential of Cold Plasma for Safe and Sustainable Food Production. *Trends in Biotechnology*, *36*, 615 – 626. DOI: <https://doi.org/10.1016/j.tibtech.2017.11.001>.
- Cammack, R., Joannou, C. L., Cao, X.-Y., Torres Martinez, C., Maraj, S. R., & Hughes, M. N. (1999). Nitrite and nitrosyl compounds in food preservation. *Biochimica et Biophysica Acta*, *1411*, 475-488. DOI: [https://doi.org/10.1016/S0005-2728\(99\)00033-X](https://doi.org/10.1016/S0005-2728(99)00033-X)
- CDC (2019), Online published: <https://www.cdc.gov/ecoli/2019/o157h7-11-19/index.html>. (accessed 8th January 2021).
- Chan, J., Xing, Y., Magliozzo, R. S., & Bloom, B.R. (1992). Killing of Virulent Mycobacterium tuberculosis by Reactive Nitrogen Intermediates Produced by Activated Murine Macrophages. *Journal of Experimental Medicine*, *175*, 1111-1122. DOI: [10.1084/jem.175.4.1111](https://doi.org/10.1084/jem.175.4.1111)
- Chen, Z., Zhu, C., Zhang, Y., Niu, D., & Du, J. (2010). Effects of aqueous chlorine dioxide treatment on enzymatic browning and shelf-life of fresh-cut asparagus lettuce (*Lactuca sativa* L.). *Postharvest Biology and Technology*, *58*, 232 - 238. DOI: [10.1016/j.jbiosc.2011.01.010](https://doi.org/10.1016/j.jbiosc.2011.01.010)
- Cho, S. H., Parsonage, D., Thurston, C., Dutton, R. J., Poole, L. B., Collet, J. F., & Beckwith, J. (2012). A new family of membrane electron transporters and its substrates, including a new cell envelope peroxiredoxin, reveal a broadened reductive capacity of the oxidative bacterial cell envelope. *mBio*, *3*, e00291-11. DOI: [10.1128/mBio.00291-11](https://doi.org/10.1128/mBio.00291-11).
- Ehlbeck, J., Schnabel, U., Polak, M., Winter, J., von Woedtke, T., Brandenburg, R., von dem Hagen, T., & Weltmann, K.-D. (2011). Low temperature atmospheric pressure plasma sources for microbial

- decontamination. *Journal of Physics D: Applied Physics*, *44*, 13002. DOI: 10.1088/0022-3727/44/1/013002.
- European Food Safety Authority and European Centre for Disease Prevention and Control (EFSA and ECDC). (2019). The European Union One Health 2018 Zoonoses Report. *EFSA Journal*, *17*, 5926. DOI: doi: 10.2903/j.efsa.2019.5926.
- FAO & WHO. (2009). Annous, B., Berran, M., Burnett, S. L., Dykes, G., Frank, J. F., Graz, M., Karunasagar, I., Lupin, H., Matthews, K., Reilly, A., Sanderson, B., & Zheng, Y. Chapter 1: USE OF CHLORINE-CONTAINING COMPOUNDS IN FOOD PROCESSING. Report of a Joint FAO/WHO Expert Meeting: Benefits and Risks of the Use of Chlorine-containing Disinfectants in Food Production and Food Processing, Ann Arbor, MI, USA, May 2008.
- FoodSafety magazine. (2018) Online published: <https://www.foodsafetymagazine.com/news/ussays-e-coli-outbreak-is-a-likely-2809d-leafy-greens-while-canada-declares-outbreak-over/>. (accessed 8th January 2021).
- Gil, M. I., Selma, M. V., Lopez-Galvez, F., & Allende, A. (2009). Fresh-cut product sanitation and wash water disinfection: Problems and solutions. *International Journal of Food Microbiology*, *134*, 37 - 45. DOI: 10.1016/j.ijfoodmicro.2009.05.021.
- Gopal, A., Coventry, J., Wan, J., Roginski, H., & Ajlouni, N. (2010). Alternative disinfection techniques to extend the shelf life of minimally processed iceberg lettuce. *Food Microbiology*, *27*, 210 - 219. DOI: 10.1016/j.fm.2009.10.006.
- Han, L., Patil, S., Boehm, D., Milosavljević, V., Cullen, P. J., & Bourke, P. (2016). Mechanisms of Inactivation by High-Voltage Atmospheric Cold Plasma Differ for *Escherichia coli* and *Staphylococcus aureus*. *Applied and Environmental Microbiology*, *82*, 450-458. DOI: 10.1128/AEM.02660-15
- Heaton, J. C., & Jones, K. (2008). Microbial contamination of fruit and vegetables and the behaviour of enteropathogens in the phyllosphere: A review. *Journal of Applied Microbiology*, *104*, 613 - 626. DOI: 10.1111/j.1365-2672.2007.03587.x
- Hägele, F., Nübling, S., Schweininger, R. M., Baur, S., Weiss, A., Schmidt, H., Menegat, A., Gerhards, R., & Carle, R. (2016). Quality improvement of fresh-cut endive (*Cichorium endivia* L.) and recycling of washing water by low-dose UV-C irradiation. *Food and Bioprocess Technology*, *9*, 1979 – 1990. DOI: 10.1007/s11947-015-1722-2
- Ikawa, S., Tani, A., Nishishima, Y., & Kitano, K. (2016). Physicochemical properties of bactericidal plasma-treated water. *Journal of Physics D: Applied Physics*, *49*, 425401.
- Issa-Zacharia, A., Kamitani, Y., Muhimbula, H. S., & Ndabikunze, B. K. (2010). A review of microbiological safety of fruits and vegetables and the introduction of electrolyzed water as an alternative to sodium hypochlorite solution. *African Journal of Food Science*, *4*, 778 – 789.
- King, A. D., Magnuson, J. A., Török, T., & Goodman, N. (1991). Microbial flora and storage quality of partially processed lettuce. *Journal of Food Science*, *56*, 459 - 461. DOI: <https://doi.org/10.1111/j.1365-2621.1991.tb05303.x>
- Kogelschatz, U. (2004). Atmospheric-pressure plasma technology. *Plasma Physics and Controlled Fusion*, *46*, B63-B75. DOI: 10.1088/0741-3335/46/12B/006.
- Krohmann, U., Neumann, T., & Ehlbeck, J. (2005). (Leibniz Institute for Plasma Science and Technology e.V. Greifswald) Method and apparatus for generating an expanding, diffuse microwave plasma. DE Patent No. 102005043278B4.

- Linley, E., Denyer, S. P., McDonnell, G., Simons, C., & Maillard, J. Y. (2012). Use of hydrogen peroxide as a biocide: new consideration of its mechanisms of biocidal action. *Journal of Antimicrobial Chemotherapy*, *67*, 1589 – 1596. DOI: 10.1093/jac/dks129
- Lukes, P., Dolezalova, E., Sisrova, I., & Clupek, M. (2014). Aqueous-phase chemistry and bactericidal effects from an air discharge plasma in contact with water: evidence for the formation of peroxyxynitrite through a pseudo-second-order post-discharge reaction of H₂O₂ and HNO₂. *Plasma Sources Science and Technology*, *23*, 015019. DOI: 10.1088/0963-0252/23/1/015019
- Lynch, M. F., Tauxe, R. V., & Hedberg, C. W. (2009). The growing burden of foodborne outbreaks due to contaminated fresh produce: Risks and opportunities. *Epidemiology and Infection*, *137*, 307-315. DOI: 10.1017/S0950268808001969.
- Matthews, K. R. (Editor). (2006). Emerging Issues in Food Safety. Microbiology of Fresh Produce. American Society for Microbiology Press (ASM Press).
- McDonnell, G., & Russell, A. D. (1999). Antiseptics and Disinfectants: Activity, Action, and Resistance [published correction appears in *Clinical Microbiology Reviews*, 2001, 14, pp. 227]. *Clinical Microbiology Reviews*, *12*, 147–179.
- Moreno-Vivián, C., Cabello, P., Martínez-Luque, M., Blasco, R., & Castillo, F. (1999). Prokaryotic Nitrate Reduction: Molecular Properties and Functional Distinction among Bacterial Nitrate Reductases. *Journal of Bacteriology*, *181*, 6573 – 6584. DOI: 10.1128/JB.181.21.6573-6584.1999
- Naïtali, M., Kamgang-Youbi, G., Herry, J. M., Bellon-Roataine, M. N., & Brisset, J. L. (2010). Combined effects of long-living chemical species during microbial inactivation using atmospheric plasma-treated water. *Applied and Environmental Microbiology*, *76*, 7662 – 7664. DOI: 10.1128/AEM.01615-10
- Odumeru, J. A., Mitchell, S. J., Alves, D. M., Lynch, J. A., Yee, A. J., Wang, S. L., Styliadis, S., & Farber, J. M. (1997). Assessment of the microbiological quality of ready-to-use vegetables for health-care food services. *Journal of Food Protection*, *50*, 954 - 960.
- Oehmigen, K., Winter, J., Hähnel, M., Wilke, C., Brandenburg, R., Weltmann, K.-D., & von Woedtke, T. (2011). Estimation of possible mechanisms of *Escherichia coli* inactivation by plasma treated sodium chloride solution. *Plasma Processes and Polymers*, *8*, 904-913. DOI: <https://doi.org/10.1002/ppap.201000099>
- Ölmez, H., & Kretschmar, J. (2009). Potential alternative disinfection methods for organic fresh-cut industry for minimizing water consumption and environmental impact. *LWT - Food Science and Technology*, *42*, 686 - 693. DOI: <https://doi.org/10.1016/j.lwt.2008.08.001>.
- Patange, A., Boehm, D., Ziuzina, D., Cullen, P. J., Gilmore, B., and Bourke, P. (2019). High voltage atmospheric cold air plasma control of bacterial biofilms on fresh produce. *International Journal of Food Microbiology*, *293*, 137–145. doi: 10.1016/j.ijfoodmicro.2019.01.005
- Pericone, C. D., Overweg, K., Hermans, P. W. M., & Weiser, J. N. (2000). Inhibitory and bactericidal effects of hydrogen peroxide production by *Streptococcus pneumoniae* on other inhabitants of the upper respiratory tract. *Infection and Immunity*, *68*, 3990-3997. DOI: 10.1128/iai.68.7.3990-3997.2000
- Pipa, A. V., Andrasch, M., Rackow, K., Ehlbeck, J., & Weltmann, K.-D. (2012). Observation of microwave volume plasma ignition in ambient air. *Plasma Sources Science and Technology*, *21*, 035009 (8pp), DOI:10.1088/0963-0252/21/3/035009.
- Pomposiello, P. J., & Demple, B. (2002). Global adjustment of microbial physiology during free radical stress. *Advances in Microbial Physiology*, *46*, 319 – 341. DOI: 10.1016/s0065-2911(02)46007-9

- Ramos, B., Miller, F. A., Brandao, T. R. S., Teixeira, P., & Silva, C. L. M. (2013). Fresh fruits and vegetables - An overview on applied methodologies to improve its quality and safety. *Innovative Food Science and Emerging Technologies*, *20*, 1 - 15. DOI: <https://doi.org/10.1016/j.ifset.2013.07.002>.
- Saltveit, M. E. (1997). Physical and physiological changes in minimally processed fruits and vegetables. In F.A. Tomas-Barberan, R.J. Robins (Eds.), *Phytochemistry of fruits and vegetables* (pp. 205 - 220). Oxford: Oxford University Press.
- Schlüter, O., Ehlbeck, J., Hertel, C., Habermeyer, M., Roth, A., Engel, K. H., Holzhauser, T., Knorr, D., & Eisenbrand, G. (2013). Opinion on the use of plasma processes for treatment of foods. *Molecular Nutrition & Food Research*, *57*, 920–927. DOI: 10.1002/mnfr.201300039.
- Schnabel, U., Andrasch, M., Stachowiak, J., Weit, C., Weihe, T., Schmidt, C., Muranyi, P., Schlüter, O., & Ehlbeck, J. (2019). Sanitation of fresh-cut endive lettuce by plasma processed tap water (PPtW) – Up-scaling to industrial level. *Innovative Food Science and Emerging Technologies*, *53*, 45-55. DOI: <https://doi.org/10.1016/j.ifset.2017.11.014>.
- Schnabel, U., Handorf, O., Stachowiak, J., Boehm, D., Weit, C., Weihe, T., Schäfer, J., Below, H., Bourke, P., & Ehlbeck, J. (2020). Plasma-Functionalized Water: from Bench to Prototype for Fresh-Cut Lettuce. *Food Engineering Reviews*, <https://doi.org/10.1007/s12393-020-09238-9> (online published).
- Schnabel, U., Handorf, O., Winter, H., Weihe, T., Weit, C., Schäfer, J., Stachowiak, J., Boehm, D., Below, H., Bourke, P., & Ehlbeck, J. (2021). The Effect of Plasma Treated Water Unit Processes on the Food Quality Characteristics of Fresh-Cut Endive. *Frontiers in Nutrition*, *7*, DOI: 10.3389/fnut.2020.627483 (accepted)
- Scudiero, D. A., Shoemaker, R. H., Paull, K. D., Monks, A., Tierney, S., Nofziger, T. H., Currens, M. J., Seniff, D., & Boyd, M. R. (1988). Evaluation of a Soluble Tetrazolium Formazan Assay for Cell-Growth and Drug Sensitivity in Culture Using Human and Other Tumor-Cell Lines. *Cancer Research*, *48*, 4827-4833.
- Shank, J. L., Silliker, J. H., & Harper, R.,H. (1962). The Effect of Nitric Oxide on Bacteria. *Applied Microbiology*, *10*, 185-189.
- Shaw, P., Kumar, N., Kwak, H. S., Park, J. H., Uhm, H. S., Bogaerts, A., Choi, E. H., & Attri, P. (2018). Bacterial inactivation by plasma treated water enhanced by reactive nitrogen species. *Scientific Reports*, *8*, 11268. DOI: 10.1038/s41598-018-29549-6.
- Shen, J., Tian, Y., Li, Y., Ma, R., Zhang, Q., Zhang, J., & Fang, J. (2016). Bactericidal effects against *S. aureus* and physicochemical properties of plasma activated water stored at different temperatures. *Scientific Reports*, *6*, 28505. DOI: 10.1038/srep28505
- Shiva, S. (2013). Nitrite: A physiological store of nitric oxide and modulator of mitochondrial function. *Redox Biology*, *1*, 40-44. DOI: 10.1016/j.redox.2012.11.005
- Tomas-Callejas, A., Lopez-Galvez, F., Sbodio, A., Artes, F., Artes-Hernandez, F., & Suslow, T. V. (2012). Chlorine dioxide and chlorine effectiveness to prevent *Escherichia coli* O157: H7 and *Salmonella* cross-contamination on fresh-cut red chard. *Food Control*, *23*, 325-332. DOI:10.1016/j.foodcont.2011.07.022.
- Torres, M. J., Simon, J., Rowley, G., Bedmar, E. J., Richardson, D. J., Gates, A. J., & Delgado, M.J. (2016). Nitrous Oxide Metabolism in Nitrate-Reducing Bacteria: Physiology and Regulatory Mechanisms. *Advances in Microbial Physiology*, *68*, 353-432. DOI: 10.1016/bs.ampbs.2016.02.007

- Traylor, M. J., Pavlovich, M. J., Karim, S., Hait, P., Sakiyama, Y., Clark, D. S., & Graves, D. B. (2011). Long-term antibacterial efficacy of air plasma-activated water. *Journal of Physics D: Applied Physics*, *44*, 472001. DOI: 10.1088/0022-3727/44/47/472001
- Tsoukou, E., Bourke, P., & Boehm, D. (2020). Temperature Stability and Effectiveness of Plasma-Activated Liquids over an 18 Months Period. *Water*, *12*, 3021. DOI: <https://doi.org/10.3390/w12113021>.
- USDA. (2019). Online published: <https://www.fsis.usda.gov/wps/portal/fsis/topics/recalls-and-public-health-alerts/recallcase-archive/archive/2019/recall-115-2019-release>. (accessed 8th January 2021).
- Vatanserver, F., de Melo, W. C. M. A., Avci, P., Vecchio, D., Sadasivam, M., Gupta, A., Chandran, R., Karimi, M., Parizotto, N. A., Yin, R., Tegos, G. P., & Hamblin, M. R. (2013). Antimicrobial strategies centered around reactive oxygen species – bactericidal antibiotics, photodynamic therapy, and beyond. *FEMS Microbiology Reviews*, *37*, 955 – 989. DOI: 10.1111/1574-6968.12026
- Vázquez-Torres, A., & Bäumlér, A. J. (2016). Nitrate, nitrite and nitric oxide reductases: from the last universal common ancestor to modern bacterial pathogens. *Current Opinion in Microbiology*, *29*, 1–8. DOI: 10.1016/j.mib.2015.09.002
- Wallhäußer, K. H. (1995). Praxis der Sterilisation - Desinfektion - Konservierung - Keimidentifizierung – Betriebshygiene. Stuttgart: Thieme-Verlag.
- Weihe, Th., Schnabel, U., Winter, H., Möller, T., Sachowiak, J., Neumann, S., Schlüter, O., & Ehlbeck, J. (2021). Reduce and refine - Plasma treated water vs. conventional disinfectants for conveyor-belt cleaning in sustainable food-production lines. *Journal of Applied Physics*, *129*, x-x. DOI: 10.1063/5.0047112, accepted.
- Wulfkühler, S., Kurfiss, L., Kammerer, D. R., Weiss, A., Schmidt, H., & Carle, R. (2013). Impact of different washing procedures on quality of fresh-cut iceberg lettuce (*Lactuca sativa* var. capitata L.) and endive (*Cichorium endivia* L.). *European Food Research and Technology*, *236*, 229 - 241. DOI: 10.1007/s00217-012-1878-5.
- Zagory, D. (1999). Effects of post-processing handling and packaging on microbial populations. *Postharvest Biology and Technology*, *15*, 313 - 321.
- Zhang, Q., Liang, Y., Feng, J., Ma, R., Tian, Y., Zhang, J., & Fang, J. (2013). A study of oxidative stress induced by non-thermal plasma-activated water for bacterial damage. *Applied Physics Letters*, *102*, 203701. DOI: <https://doi.org/10.1063/1.4807133>.

Highlights:

- Plasma functionalised water (PFW) successfully used as wash water additive on lettuce
- PFW treatment enhances the microbiological safety of fresh-cut endive
- PFW showed promising results compared to industry standard chlorine dioxide (ClO₂)
- Mechanism of action of PFW based on reactive oxygen/nitrogen species (RONS)