



Title	The Use of Ramp Superposition to Analyse the Influence of Road Irregularities on Maximum Beam Stresses due to a Moving Load
Authors(s)	Cantero, Daniel, González, Arturo, O'Brien, Eugene J.
Publication date	2007-09
Publication information	Cantero, Daniel, Arturo González, and Eugene J. O'Brien. "The Use of Ramp Superposition to Analyse the Influence of Road Irregularities on Maximum Beam Stresses Due to a Moving Load." Civil-Comp Press, September 2007. https://doi.org/10.4203/ccp.86.196 .
Conference details	Proceedings of the Eleventh International Conference on Civil, Structural and Environmental Engineering Computing, St. Julians, Malta, 18-21 September, 2007
Publisher	Civil-Comp Press
Item record/more information	http://hdl.handle.net/10197/6233
Publisher's version (DOI)	10.4203/ccp.86.196

Downloaded 2026-05-01 23:35:05

The UCD community has made this article openly available. Please share how this access benefits you. Your story matters! (@ucd_oa)



© Some rights reserved. For more information

Abstract

Maximum static bending stresses take place at mid-span for a simply supported beam model subject to a moving load but the maximum total stresses may fall in a different section as result of many mechanical parameters involving vehicle, beam and road profile interaction. This paper uses the concept of ramp superposition to analyse the influence of a road profile on the beam stresses and to determine the critical sections where maximum stresses develop. The method also allows identifying those road segments that contribute in a higher degree to those stresses.

Keywords: bridge, dynamics, vehicle, interaction, bending moment, ramp, superposition, ISO profile .

1 Introduction

During the last years, abundant work has been carried out in the field of bridge dynamics, showing that impact factors recommended by existing codes may result over-conservative when assessing the dynamics effects of moving loads on highway bridges. This conservatism is due to the uncertainty of many of the parameters involved in the vehicle bridge dynamic interaction. This uncertainty can be reduced using on-site data and experimentally validated mathematical models to derive a more realistic dynamic amplification factors. While most of the research focus on the study of stresses developed at a selected number of sections, mainly mid-span, this paper considers the stresses developed through the whole bridge length. The maximum bending moment due to a vehicle crossing doesn't always take place at mid-span. Compared to the moment at mid-span location, the maximum moment of the structure can be located relatively far apart and be of significant higher magnitude. This paper evaluates the magnitude and the area of influence of these maximum stresses. First the models employed to simulate the crossing of a vehicle

over a beam are introduced. The concept of ramp superposition is used then to explain the influence of road irregularities on maximum stresses on the beam. Li et al. [1, 2] have shown that it is possible to scale the effect of a unit ramp at a specified location with good accuracy. So, the contribution to the dynamic response of a single ramp can be obtained by multiplying the unit ramp results by an appropriate magnitude, which could be either positive or negative. Furthermore, it is shown that a profile with multiple ramps can be studied as the sum of the smooth profile dynamic effect plus the contribution of each ramp, which has been named as principle of ramp superposition. This paper uses this approach to characterise a road profile regarding maximum bridge stresses across its entire length.

2 Vehicle-Bridge Interaction Model

The vehicle model used in this study is a quarter-car travelling at constant velocity, c , moving from left to right. The tyre is modelled like a mass, m_t , linked to the road by a spring of stiffness K_t . On the other hand, the main mass of the vehicle, m_s , is linked to the tyre by a spring of stiffness K_s and a passive viscous damper of value C_s . In Figure 1 a sketch of quarter-car is shown.

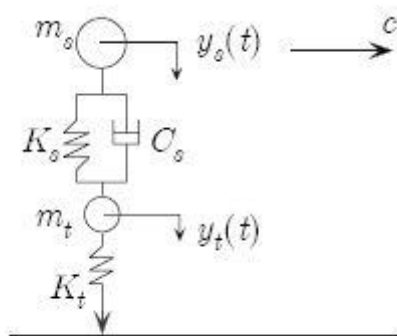

Figure 1: Sketch of quarter-car

The vehicle parameters are taken from Cebon [3] proposed values and are listed below in Table 1.

Description		Value
Unsprung mass	m_t	420 kg
Sprung mass	m_s	4450 kg
Suspension stiffness	K_s	1000 KN/m
Tyre stiffness	K_t	1950 KN/m
Passive damping coefficient	C_s	15 KN s/m
Speed	C	25 m/s

Table 1: Vehicle parameters

The equations of motion of the system are given by Equations (1, 2),

$$m_s \frac{d^2 y_s(t)}{dt^2} + K_s [y_s(t) - y_t(t)] + C_s \left[\frac{dy_s(t)}{dt} - \frac{dy_t(t)}{dt} \right] = 0 \quad (1)$$

$$(m_t + m_s)g - m_t \frac{d^2 y_t(t)}{dt^2} + K_s [y_s(t) - y_t(t)] + C_s \left[\frac{dy_s(t)}{dt} - \frac{dy_t(t)}{dt} \right] - R(t) = 0 \quad (2)$$

where $R(t)$ is the dynamic force of the vehicle on the bridge surface, given by Equation (3). In the numerical model, the tire force is prevented from applying negative forces to the bridge surface.

$$R(t) = K_r [y_t(t) - v(x_1, t) - r(x_1)] \geq 0 \quad (3)$$

The beam model is a simple supported Euler-Bernoulli beam with constant cross section and mass per unit length, as shown in Figure 2.

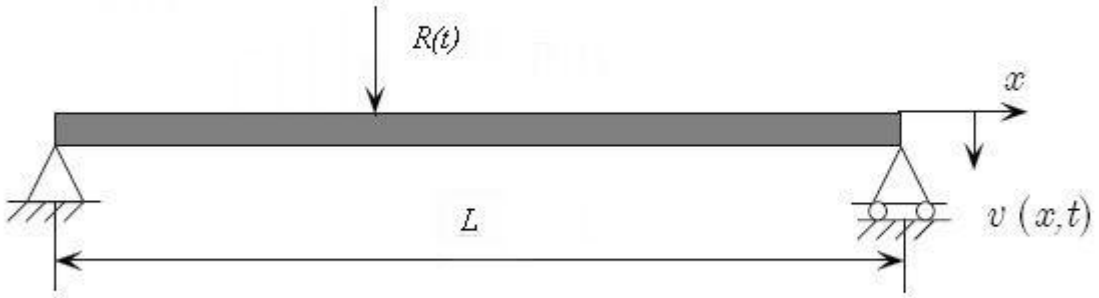

Figure 2: Sketch of simple supported beam

The beam behaviour is described by Equation (4), where $v(x, t)$ is the deflection of the beam and δ is the Dirac function.

$$E \cdot J \frac{\partial^4 v(x, t)}{\partial x^4} + \mu \frac{\partial^2 v(x, t)}{\partial t^2} + 2 \cdot \mu \cdot \omega_b \frac{\partial v(x, t)}{\partial t} = \delta(x - c \cdot t) \cdot R(t) \quad (4)$$

The definition and value of the parameters employed in the beam model are listed in Table 2.

Description		Value
Length	L	25 m
Mass per unit length	μ	18358 kg/m
Young's Modulus	E	$3.5 \cdot 10^{10}$ N/m ²
Section moment of inertia	J	1.3901 m ⁴
Damping	e	3 %

Table 2: Bridge parameters

Equation (4) is solved by the method of finite Fourier integral transformation defined by Equations (5, 6).

$$q_{(j)}(\tau) = 2 \int_0^1 y(\xi, \tau) \cdot \sin(j \cdot \pi \cdot \xi) \cdot d\xi \quad (5)$$

$$y(\xi, \tau) = \sum_{j=1}^{\infty} q_{(j)}(\tau) \cdot \sin j \cdot \pi \cdot \xi \quad (6)$$

By combining Equations (4,5,6), differential Equation (7) is obtained

$$\ddot{q}_{(j)}(\tau) = \frac{96}{\pi^2 \alpha^2} \varepsilon \cdot R(\tau) \cdot \sin(j \cdot \pi \cdot \xi) - j^4 \frac{\pi^2}{\alpha^2} q_{(j)}(\tau) - \frac{g}{\alpha} \dot{q}_{(j)}(\tau) \quad (7)$$

where $q_{(j)}(\tau)$ is normalized deflection of the beam, ξ the generalized position coordinate, τ the generalized time coordinate of the beam, α , ε and θ are dimensionless parameters concerning speed, position of the load and natural frequency of the bridge. A detailed explanation can be found in Frýba [4].

The aim of the simulation is to study the bending stresses developed on the beam while the vehicle is passing over. Frýba suggests to calculate the total bending moment on the beam as the sum of two bending moments, see Equation (8).

$$M(\xi, \tau) = M_R(\xi, \tau) + M_\mu(\xi, \tau) \quad (8)$$

$$M_R(\xi, \tau) = \begin{cases} 2 \cdot \varepsilon \cdot \bar{R}(\tau) \cdot \xi & \text{for } \xi < \frac{1}{2} \\ 2 \cdot \varepsilon \cdot \bar{R}(\tau) \cdot (1 - \xi) & \text{for } \xi \geq \frac{1}{2} \end{cases} \quad (9)$$

$$M_\mu(\xi, \tau) = -\frac{1}{12} \alpha^2 \sum_{j=1}^{\infty} \frac{1}{j^2} \ddot{q}_{(j)}(\tau) \cdot \sin j \cdot \pi \cdot \xi \quad (10)$$

where $M_R(\xi, \tau)$ is the bending moment at ξ produced by load $R(\tau)$, and it corresponds to the quasistatic component (Equation (9)), while $M_\mu(\xi, \tau)$ is the bending moment produced by inertia forces (Equation (10)).

It is advantageous to compute the bending moment using Equation (8) since it is accurate enough even considering a small number of modes of vibration. More details could be found in Fryba [4]. This paper will analyse the Normalized Bending Moment (*NBM*), defined as the maximum total bending moment divided by the maximum static bending moment. For the case of a simply supported beam, the maximum static moment always take place at mid-span, but the location of the

maximum total moment will vary depending on the elements involved in the vehicle bridge interaction.

3 The extension of the unit ramp concept to multiple sections

Li et al. [1,2] developed the principle of ramp superposition to explain the influence of the road profile on bridge dynamic amplification. It evaluates the importance of each road singularity according to its magnitude and location. They apply this concept to analyse the stresses at one single section, i.e., mid-span. The approach is extended here to take into account the maximum stresses taking place anywhere across the entire beam.

3.1 Definition of Unit Ramp

A unit ramp is defined as a ramp of 1mm height over a 100mm length as illustrated in Figure 3. The ramp location is defined by reference to the start point of its 100mm length. This segment length was chosen based on the assumption that only frequencies of less than 10 cycles per meter (wavelengths of greater than 100mm) are significant [5].

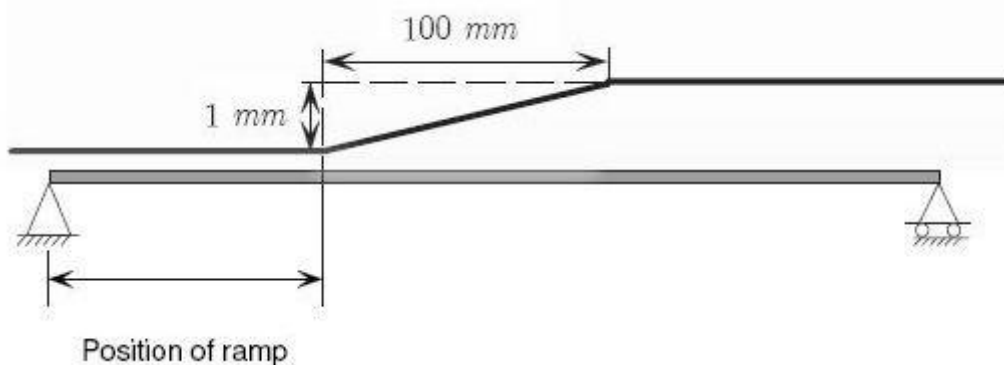

Figure 3: Unit Ramp

In order to analyze the effect of particular road irregularities on bridge dynamic amplification, the road profile is discretized into a series of ramps and the contribution of each ramp is evaluated individually. The stress due to a unit ramp is obtained for every possible ramp location. Then, the stress due to a smooth profile is subtracted from the stress due to the unit ramp to obtain the contribution purely due to the ramp. The process is repeated moving the unit ramp across the vehicle path. The total effect due to a road profile can be obtained from multiplying the effect of each unit ramp by the magnitude of the measured ramp and adding together the effect of all ramps. The unit ramp results refer to a particular vehicle and bridge of

given mechanical characteristics, and different unit ramp results will need to be used as reference if the vehicle properties are varied.

Li et al [1, 2] have shown the principle of ramp superposition offers accurate results once the bridge deflection is small enough compared to the road irregularities and assumed permanent contact between the wheel and the surface. Small inaccuracies can also be due to the discretization process of the road profile.

The contribution to the maximum *NBM* at mid-span, is shown in Figure 4, for a range of ramp locations before and over the bridge. It can be seen how the contribution of a ramp in the second half of the bridge to mid-span bending is negligible.

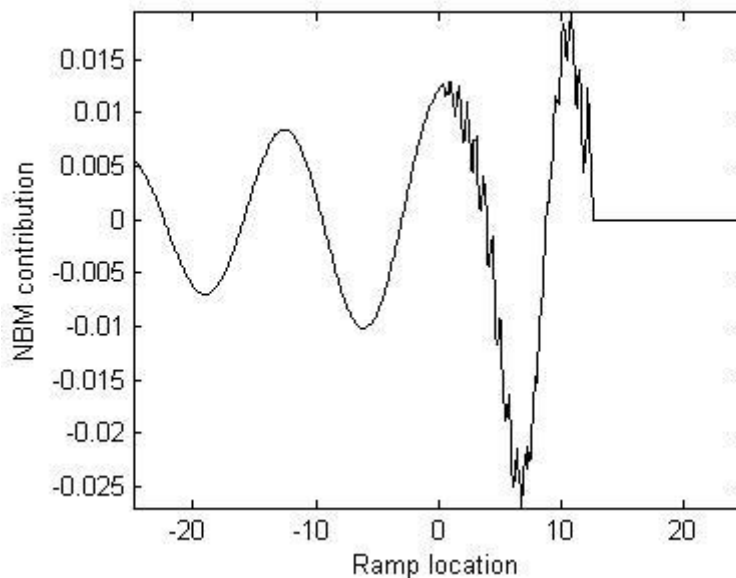

Figure 4: *NBM* contribution for different ramp locations at mid-span

3.2 Application to all beam sections

The dynamic response of bridge-vehicle interaction is a complex problem, and the maximum total bending moment value is commonly not located at exactly mid-span. The *NBM* is obtained, in Figure 5, for a number of section locations along the beam and compared to the maximum moment at mid-span. If these *NBM* at different sections are plotted together, it is possible to obtain an envelope of maximum moments throughout the bridge length, which in this paper will be referred as M^* .

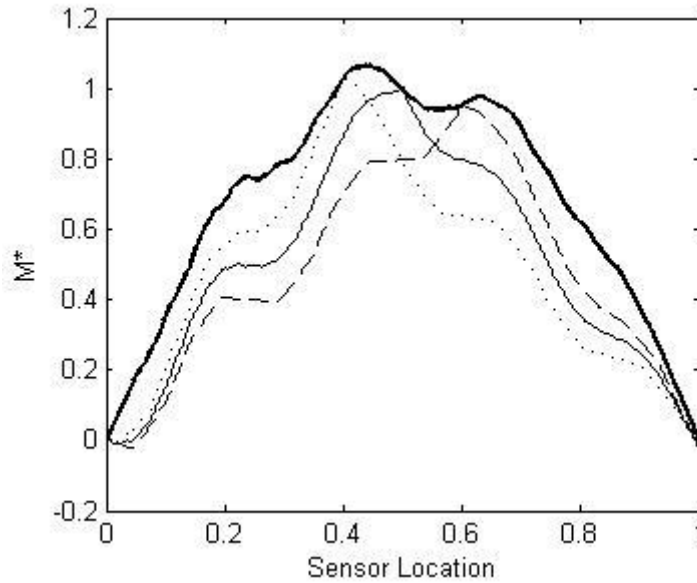

Figure 5: *NBM* for section locations at 40% *L* (Dotted); at 50% *L* (Thin solid line); at 60% *L* (Dashed line); M^* (Thick solid line)

The envelope, M^* , can be used to get the maximum bending stresses and to identify the section or sections where they are taking place. I.e., for a complete smooth profile and the bridge and vehicle properties defined in Section 2, the maximum value of M^* is 1.064 and it is located at 44%*L*. For the same case, the mid-span maximum value of M^* is only 0.998.

The unit ramp can be extended to consider all possible sections across the beam. I.e., Figure 5 shows the unit ramp contribution for the mid-span section, while Figure 6 shows the unit ramp contribution for any section location.

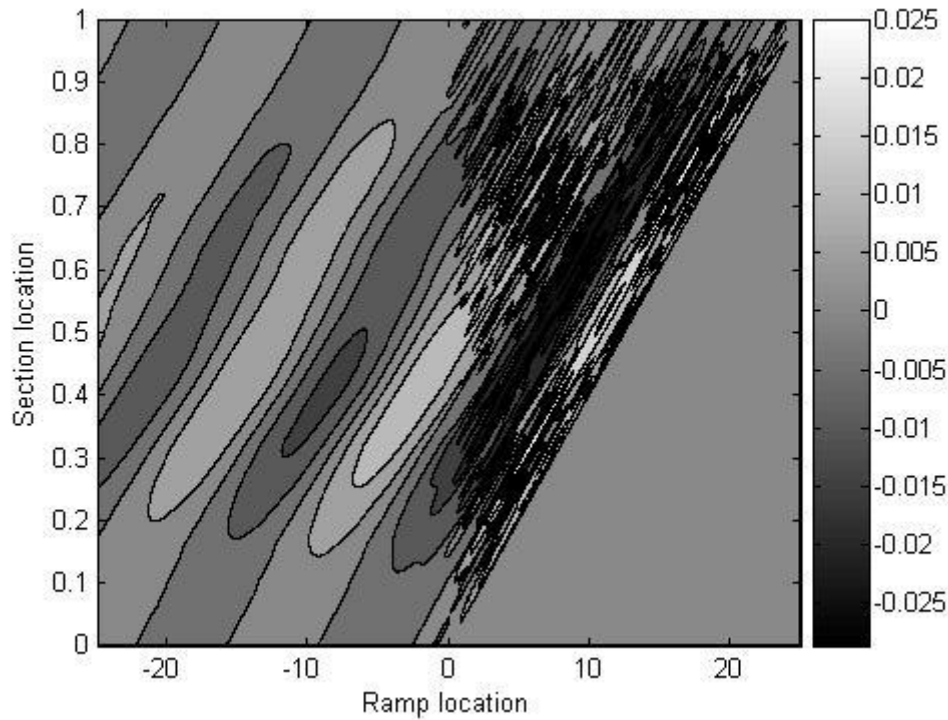

Figure 6: M^* contribution along the beam for various ramp locations

Figure 6 shows that the influence of each ramp on the section stresses can be either positive or negative, and ramps located on the first half of the bridge and on the near approach have a strong influence on the maximum moment. When the ramp under study is on the bridge, the contribution to M^* becomes more variable due to the direct impact on the bridge. There is a significant area where the contribution to M^* has zero value. This is due to the fact that the ramp considered is positioned after the section under study. For these cases, the M^* is equivalent to the one with smooth profile, therefore the contribution is zero.

4 Example

For given vehicle and bridge properties, the use of ramp superposition requires the following steps:

1. Calculate dynamic response of the bridge due to the passing vehicle on a completely smooth profile.
2. Discretization of the road profile into a series of ramps defined by their locations and scale (magnitude referred to the unit ramp).
3. For each ramp location, the unit ramp contribution to M^* at that location, must be multiplied by its corresponding scale factor.
4. Repeat steps 1 to 3 for each discretized ramp and add all together, to obtain the M^* corresponding to the entire road profile.

To illustrate how the principle of ramp superposition can be applied, a road profile is idealised here as a smooth surface with a bump at a specified location. The bump consists of a 5cm high ramp upwards and another 2cm high downwards as sketched in Figure 7.

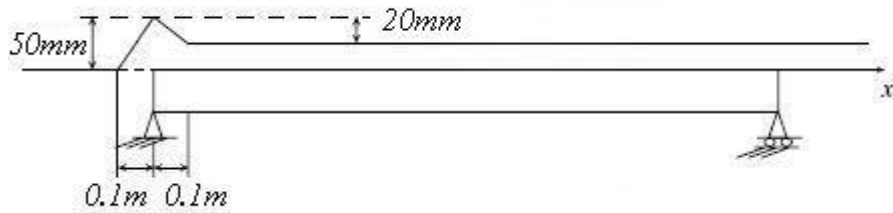
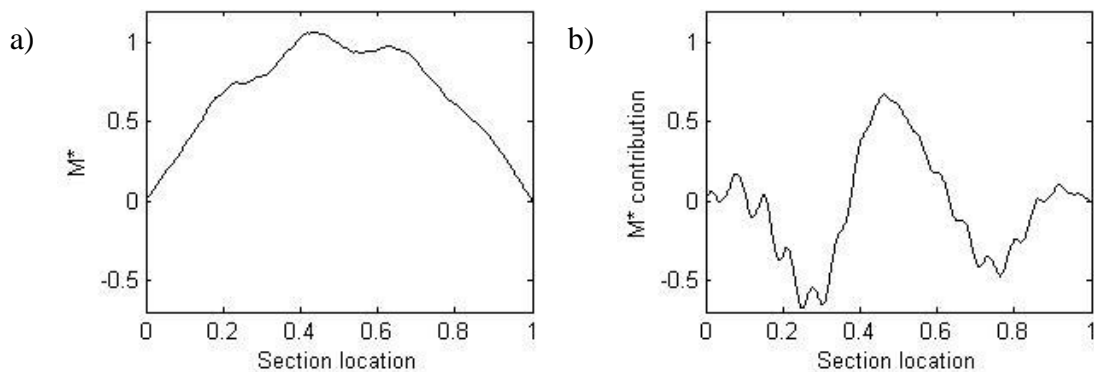

Figure 7: Sketch of bump

Following the steps described above, the dynamic response of the bridge produced by the crossing of the vehicle on the bridge is calculated and showed in Figure 8.

1. Figure 8.a is the envelope M^*_{smooth} due to the vehicle travelling on a smooth profile.
2. Since the unit ramp used is 1mm high, the scaling factors are 50 and -20 for each ramp respectively.
3. The M^* contributions of both ramps, are obtained from slices of Figure 6 and multiplied by it corresponding scaling factor. Therefore Figure 8.b is sliced at -0.1 multiplied by 50, while Figure 8.c is sliced at 0m and multiplied by -20.
4. Adding results together, it is possible to obtain the total M^* shown in Figure 8.d.



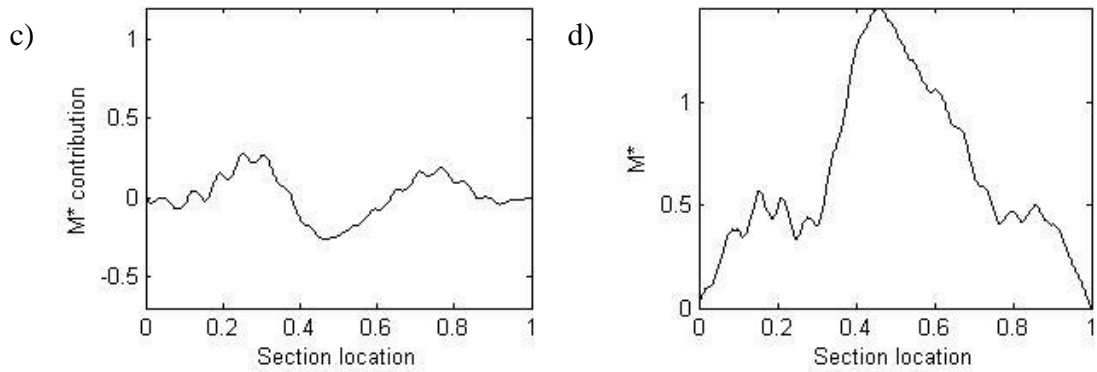

Figure 8: a) Smooth profile M^* ; b) Ramp 1 M^* contribution; c) Ramp 2 M^* contribution; d) Superposition

It can be seen that the shape of both M^* contributions is very similar but for the orientation and the scale factor. Ramp 1 contribution has one positive and two negative areas, while ramp 2 is the opposite. This is due to the fact that the second ramp goes downwards and as result, it has a negative value.

4.1 Analysis of road profiles

The bridge response depends very strongly on the roughness of the road profile, the magnitude of the individual road irregularities and their location. In this section, the concept of ramp superposition is used to analyse more realistic road profiles generated using ISO recommendations [6]. This road generation is a random process described by a power spectral density function that vary depending on the road class from A ('very good') to E ('very poor'). One class A and one class B road profiles are generated and shown in Figure 9.

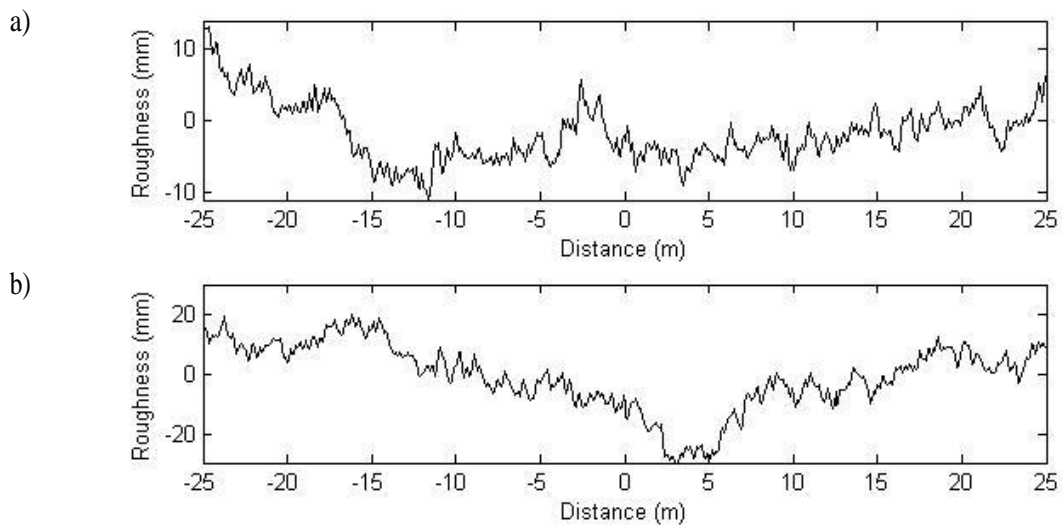

Figure 9: a) Class A road profile ('Very Good'); b) Class B road profile ('Good')

The scale factors corresponding to each road profile are represented in Figure 10.

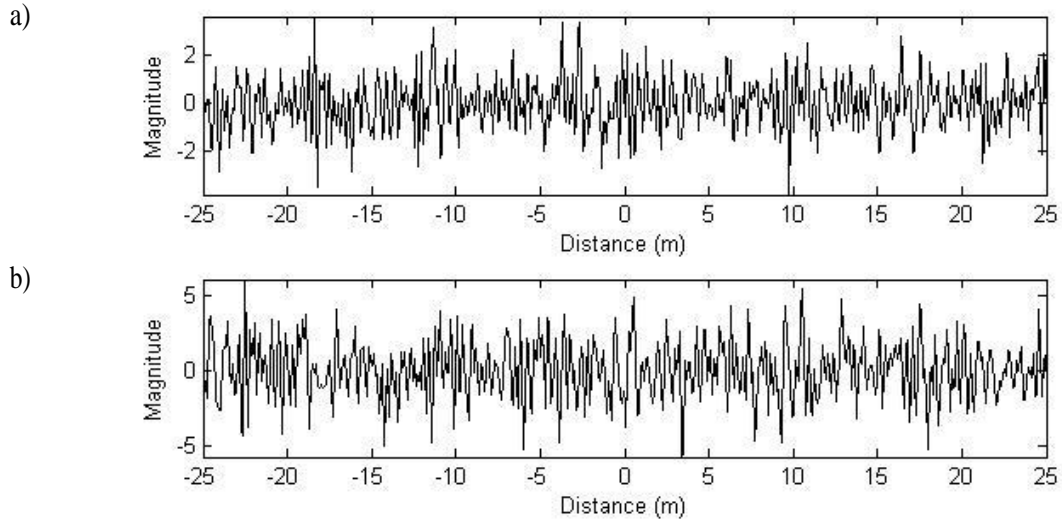
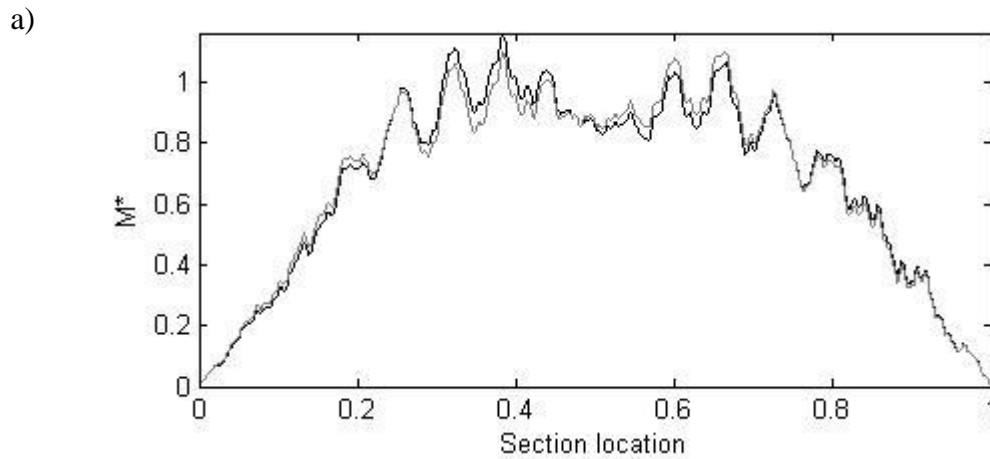

Figure 10: a) Scale factors for road profile class 'A'; b) Scale factor for road profile class 'B'

Ramp superposition is then applied to each profile multiplying the scale factor for each location by its corresponding unit ramp contribution, and finally, adding all ramp contributions. The results are shown and compared to the exact mathematical solution in Figure 11.



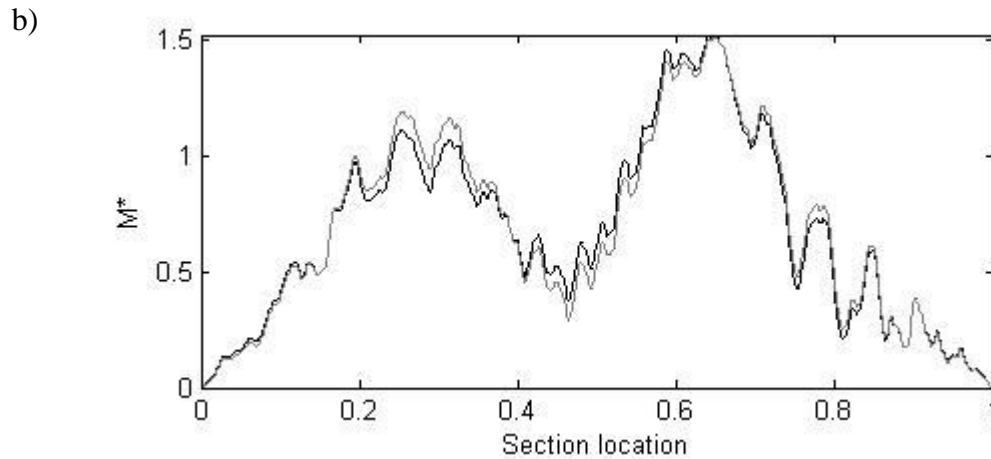

Figure 11: Black line = Exact solution; Grey line = Superposition result; a) For road profile class 'A'; b) For road profile class 'B'.

From Figures 11.a and 11.b, it can be seen the ramp superposition method offers a good approximation of the exact solution. The maximum M^* values are very close, and the critical sections where peaks develop can be predicted with a high degree of accuracy. The importance of the ramp superposition approach is that it allows to easily evaluate and locate the dynamic contribution caused by mayor discontinuities of the profile (humps, holes or damaged joints at the approach or on the bridge). A better understanding of the relationship between road profile and bridge dynamics and safety can obviously be used in road maintenance strategies.

5 Conclusions

In this paper, the principle of ramp superposition has been employed to gather an understanding of the influence a specified road profile. This approach allows to quantify the dynamic contribution of a road section to the bridge response for a given vehicle.

A quarter-car model travelling on a simple supported beam has been used to derive the envelope of maximum normalised bending moments across the beam. This envelope shows that maximum total moments can take place away from mid-span with a significantly higher value.

Three types of road profiles have been analysed using and extending the ramp superposition principle to the entire beam length. The profiles were a simplified model with a single bump at the bridge entrance and two ISO randomly generated profiles of class 'A' and 'B'. The approximation provided by the ramp superposition method gave a good match with the exact solution derived from the differential equations, and it has the advantage of giving an insight into the individual contribution to dynamics of each road segment.

References

- [1] Y. Li, E.J. O'Brien, A. González, "The Development of a Dynamic Amplification Estimator for Bridges with Good Road Profiles", in "Journal of Sound and Vibration", Vol. 293, 125-137, (2006).
- [2] E.J. O'Brien, Y. Li, A. González, "Bridge Roughness Index as an Indicator of Bridge Dynamic Amplification", in "Computers & Structures", Vol. 84, 759-769, (2006).
- [3] D. Cebon, "Handbook of Vehicle- Road Interaction", Swets & Zeitlinger, 1999.
- [4] L. Fryba, "Vibration of Solids and Structures Under Moving Loads", Noordhoff International Publishing, Groningen, The Netherlands, 1971.
- [5] O. Coussy, M. Said, J.P. Van Hoove, "The influence of random surface irregularities on the dynamic response of bridges under suspended moving loads", "Journal of Sound and Vibration", Vol. 130 (2), 313-320, 1989.
- [6] ISO8608, "Mechanical vibration-road surface profiles-reporting of measure data", 1995.