



Title	Optimal distributed generation plant mix with novel loss adjustment factors
Authors(s)	Keane, Andrew, O'Malley, Mark
Publication date	2006-06
Publication information	Keane, Andrew, and Mark O'Malley. "Optimal Distributed Generation Plant Mix with Novel Loss Adjustment Factors." IEEE, June 2006. https://doi.org/10.1109/PES.2006.1709091 .
Conference details	Paper presented at the IEEE PES General Meeting 2006, Montreal, Quebec, Canada, 18-22 June 2006
Publisher	IEEE
Item record/more information	http://hdl.handle.net/10197/3315
Publisher's statement	Personal use of this material is permitted. Permission from IEEE must be obtained for all other uses, in any current or future media, including reprinting/republishing this material for advertising or promotional purposes, creating new collective works, for resale or redistribution to servers or lists, or reuse of any copyrighted component of this work in other works.
Publisher's version (DOI)	10.1109/PES.2006.1709091

Downloaded 2026-05-01 23:41:35

The UCD community has made this article openly available. Please share how this access benefits you. Your story matters! (@ucd_oa)



© Some rights reserved. For more information

Optimal Distributed Generation Plant Mix with Novel Loss Adjustment Factors

A. Keane, *Student Member, IEEE*, M. O'Malley, *Senior Member, IEEE*

Abstract—The distributed generation (DG) plant mix connected to any network section has a considerable impact on the total amount of DG energy exported and on the amount of losses incurred on the network. A new method for the calculation of loss adjustment factors (LAFs) for DG is presented, which determines the LAFs on a site specific and energy resource specific basis. A mixed integer linear program is formulated to optimally utilise the available energy resource on a distribution network section. The objective function incorporates the novel LAFs along with individual generation load factors, facilitating the determination of the optimal DG plant mix on a network section. Results are presented for a sample section of network illustrating the implementation of the optimal DG plant mix methodology for two representative energy resource portfolios.

Index Terms—Power distribution planning, Losses, Energy resources, Integer programming, Dispersed storage and generation.

I. INTRODUCTION

IN accordance with EU Directive 96/92/EC all EU countries are in the process of opening up their electricity sector to competition [1]. This, among other drivers, such as the impact of harmful emissions on the environment, has fuelled the interest of large numbers of small independent developers to consider investing in low capital, small scale, fast revenue generating projects, such as wind and biomass generation [2]. These projects are described as distributed generation (DG) which can be defined as small-scale generation, which is not directly connected to the transmission system and is not centrally dispatched. The rapid increase in these distributed generators [3] has a significant impact on the active and reactive power flows within the distribution network and therefore also on the losses. Loss adjustment factors are used to take account of the generator's average impact on losses and to appropriately adjust the generator's metered output.

DG capacity has traditionally been allocated on a maximum capacity basis. A number of approaches to the allocation of DG capacity have previously been developed [4], [5] and [6]. In [4] a method is presented utilising OPF for the allocation of generation capacity, which includes a detailed fault level constraint. In [5] a methodology is developed which maximises the total DG capacity on a network section subject

to the technical constraints on the network. In [6] an approach is developed which maximises the DG capacity while taking account of losses and thus increases the energy delivered from DG. This paper also highlights that the DG plant mix has a significant effect on the efficiency of energy delivery. These papers have various objectives but all were concerned with the allocation of capacity. However, a further question beyond the allocation of capacity arises, what plant is taking up this capacity and what impact does this generation plant mix have on losses?

Here novel LAFs are proposed which determine the average effect of DG on losses within the network on a site specific and energy resource specific basis, thereby providing an appropriate pricing signal for the connection of DG. In any area there will be a limited energy resource, be it wind, biomass, or landfill gas (LFG) etc. This constraint is included in [5]. However, the question of how best to utilise the available energy resource was not been addressed in this paper, in particular the impact of load factors and operating characteristics on the efficiency of energy delivery. If the optimal capacity allocation for a network section is calculated using the method from [5], the question then arises of where to connect the available energy resource. The DG plant mix has a significant effect on the efficiency of energy delivery. In particular the load factors (LF) and operating characteristics of various energy sources were shown to have an impact which cannot be taken into account when DG is allocated on a capacity basis. The energy resource specific LAFs can be used to determine the optimal plant mix on a section of distribution network. The energy resource will be location constrained in a number of cases, i.e. wind and hydro. However, even allowing for these constraints, there is scope for a considerable improvement in losses and thus in energy delivery efficiency, if the optimal allocation of DG capacity is coupled with the potential benefits of the optimal plant mix.

The result is a bi-level optimisation problem, with the first part being the optimal capacity allocation from [5] and the second part being the plant mix optimisation problem described above. This plant mix problem can be formulated as a mixed integer linear program (MILP) to maximise the benefit from the finite and possibly diverse range of energy sources, subject to the constraints of energy resource location, feasible plant size and the optimal capacity allocation determined from [5]. The objective is to maximise the total energy delivered from DG. The application of LAFs and the calculation of novel LAFs are described in Section II. The calculation of the effective load factors (ELFs) is described in Section III. The methodology including the formulation of the objective

This work has been conducted in the Electricity Research Centre, University College Dublin, which is supported by ESB Networks, ESB Powergen, ESB National Grid, Cylon, the Commission for Energy Regulation, Airtricity and Enterprise Ireland. A. Keane is funded by Sustainable Energy Ireland through a postgraduate research scholarship from the Irish Research Council for Science Engineering and Technology. A. Keane and M. O'Malley are with the School of Electrical, Electronic & Mechanical Engineering, University College Dublin, Dublin 4, Ireland (Ph: +353 (0)1 7161857; e-mail: andrew.keane@ee.ucd.ie; mark.omalley@ucd.ie)

function and constraints is described in Section IV. Results are given in Section V, with discussion and conclusion in sections VI and VII respectively.

II. LOSS ADJUSTMENT FACTORS

Distribution loss adjustment factors are used by many network operators to take account of the average impact of DG on losses resulting from distributed generators [7], [8]. These loss adjustment factors are applied to the energy metered at the point of connection to the network. A new method has been developed to calculate individual loss factors for each bus taking into account the amount and type of generation connected at each bus. The loss factors reward generators for ameliorating losses and penalise them for increasing losses on a site specific and energy resource specific basis. By their nature, losses vary nonlinearly with changing power flows, nonetheless by utilising the available knowledge of load behaviour, energy resource load factors and network characteristics, the average effect of DG plant on losses may be determined.

A certain amount of electrical losses due to the flow of power is inevitable and as such these losses create an operating cost [9]. Similar to any operating cost it must be balanced against other costs and objectives. Generally generic LAFs are calculated for each voltage level and are based on the ratio of energy metered at distribution input points (i.e. distributed generators and transmission stations) to energy metered at distribution exit points (i.e. customer load). These figures reflect the general losses incurred for each voltage level on the distribution network. The novel loss adjustment factors proposed here are calculated on an energy resource specific and site specific basis, rather than using a generic value for each voltage level as done by some distribution network operators [7]. They seek to take account of the average impact of each generator on losses within the whole distribution network section.

The loss adjustment factor for the i th bus and j th energy resource (LAF_{ij}) is given by Equation (1).

$$LAF_{ij} = \frac{P_{BaseLoss\ ij} - P_{GenLoss\ ij}}{P_{Opt\ i}} \quad i \forall N, j \forall M. \quad (1)$$

where $P_{BaseLoss\ ij}$ and $P_{GenLoss\ ij}$ are the base amount and generation amount of losses related to the i th bus respectively. $P_{Opt\ i}$ is the optimal capacity allocation as determined by the method in [5] and M and N are the number of energy resources and buses respectively. $P_{BaseLoss\ ij}$ is determined by calculating the losses when there is no generation connected at the i th bus. To represent the average probable value of generation at all buses, a load factor is determined for each bus that is equal to the weighted average of the load factors of the available energy at each bus. The optimal generation allocation for each bus is then scaled by these average load factors. The load values at each bus are set to their average values. The resulting loss factors (LAF_{ij}) are positive if they reduce losses and negative if they increase losses over the base case. The losses incurred on the line from each energy source to each bus are calculated to determine the connection losses

for each bus, which is then factored into the calculation of each LAF_{ij} .

The optimal capacity allocation for any network section can be determined from [5]. Losses are more dependent on the amount of generation at certain buses within the network than others. As a result the plant mix at these buses will have a significant effect on the losses and hence on the efficiency of energy delivery. The calculation of new individual loss factors LAF_{ij} encourages the achievement of this optimal plant mix. Using the load factors for each energy resource and load data from ESB Networks and ESB National Grid [10] [11], the average effect of each energy resource at each bus may be determined, resulting in a loss factor for each energy resource at each bus as shown in Equation (1).

III. LOAD FACTORS

Load factors (LF) express the energy output of a generator as a fraction of the maximum possible energy output that is produced by a generator in a year. Generic load factors for various energy sources are well established and are shown in Table I [12] [13]. It can be seen that there is a diverse range of values for the various generation technologies. The specific value of the load factors can vary depending on the energy resource and plant operation.

TABLE I
GENERATION LOAD FACTORS

Energy Source	LF
Biomass	0.85
LFG	0.70 - 0.90
Wind	0.25 - 0.40
Hydro	0.30 - 0.50
Tidal	0.25 - 0.30
Wave	0.25

The fraction of this energy which is actually delivered to load or exported to the transmission system is dependent on the losses incurred. The loss adjustment factors calculated by the method above, facilitate the calculation of an effective load factor (ELF_{ij}) for each energy resource and bus. In each case the LF is scaled slightly upwards or downwards depending on the impact on losses. The equation for the calculation of the ELF is shown in Equation (2).

$$ELF_{ij} = LF_j(1 + LAF_{ij}) \quad i \forall N, j \forall M. \quad (2)$$

These effective load factors can then be employed in the determination of the optimal DG plant mix for any network section.

IV. METHODOLOGY

A. Objective Function

The objective of the methodology is to maximise the amount of DG energy serving load or exported to the transmission system, by making best use of the existing network assets and available energy resource. The objective is formulated as a

mixed integer linear program. The inclusion of the effective load factors in the objective function means that the available DG plant mix is utilised optimally, i.e. the amount of energy delivered from the available energy resource is maximised. The inclusion of the ELFs means that the plant is allocated based on the average amount of energy that is delivered, i.e. with losses taken into account. The objective function is given in Equation (3).

$$P_{Avg} = \sum_{j=1}^M \sum_{i=1}^N P_{avail_{ij}} ELF_{ij} Plant_{ij} \quad (3)$$

Where P_{Avg} is the average power from DG serving load or delivered to the transmission system, $P_{avail_{ij}}$ is the available energy resource of the j th energy resource at the i th bus. $Plant_{ij}$ are the integer control variables representing the allocation of available plant j at the i th bus. A linear program formulation can be used, but this results in allocations of unrealistically small generation. A MILP formulation is used to avoid this and the size of the generation blocks to be allocated can be set to an appropriate value. As a result $Plant_{ij}$ is allocated in integer blocks of appropriate size dependent on the available energy resource. The commercially available software ILOG CPLEX is used to formulate the objective function and constraints [14].

B. Constraints

There are a number of constraints on the allocation of the generation technologies to each bus.

1) *Capacity Allocation*: The generation plant mix allocated to the i th bus must not exceed the optimal allocation for each bus as calculated from [5].

$$\sum_{j=1}^M Plant_{ij} P_{avail_{ij}} \leq P_{Opt_i} \quad i \forall N. \quad (4)$$

2) *Location Constraints*: Although there may be an abundant energy resource in a general area, the distance between an energy resource and a bus may make the connection of certain resources to certain buses infeasible. This is particularly applicable to LFG, wind or hydro generation. Alternatively an energy source may be located relatively close to a number of buses, hence there will be a number of connection options. Where location constraints arise they are included in the formulation in the form shown in Equation (5).

$$Plant_{ij} = 0 \quad j \forall K, \quad i \forall N. \quad (5)$$

Where K is the set of energy resources that cannot be connected to the i th bus.

3) *Plant Size Constraints*: The use of an MILP formulation generally avoids infeasible allocations, however for some plants it is only feasible to install the plant in one large allocation, i.e. biomass. To take account of this, constraints are included on the appropriate generation excluding smaller allocations.

$$Plant_{ij} = \{0, 1\} \quad i \forall N, \quad j \forall L. \quad (6)$$

Where L is the set of plant types which can only be allocated in a single block.

V. RESULTS

A. 38kV Test System

The test system chosen is a typical section of the Irish 38kV distribution network. Results are given here for a 7 bus section as shown in Figure 1. The section of distribution network is modelled in DIgSILENT Powerfactory. Load values for each bus were obtained from ESB National Grid [11] and ESB Networks [10]. The losses considered in this paper are the load losses, i.e. the losses which are dependent on the power flows in the system. The no load losses are assumed to be unaffected by the placement of generation. All lines connecting generators to buses are assumed to be of the same standard rating.

B. Loss Adjustment Factors

Table II shows the loss adjustment factors for the section of network shown in Figure 1 as calculated from Equation (1) for a number of possible generation technologies.

TABLE II
GENERATION LOSS ADJUSTMENT FACTORS

	A	B	C	D	E	F	G
Bio	0.0	0.0	-0.0026	0.0103	0.0007	0.0311	-0.002
LFG	0.0	0.0	0.0003	0.0135	0.0015	0.0319	-0.001
Hydro	0.0	0.0	0.0057	0.0165	0.0026	0.0257	0.003
Wind	0.0	0.0	0.0057	0.0160	0.0025	0.0236	0.003
Tidal	0.0	0.0	0.0057	0.0160	0.0025	0.0236	0.003

It can be seen that each energy resource has a different impact on losses depending on where it is located. Generally it would seem that DG improves losses, but it is evident from values such as $LAF_G^{Biomass} = -0.0022$, that DG also has the potential to increase losses in certain cases.

C. Effective Load Factors

The effective load factors (ELF_{ij}) for each energy resource at each bus are given in Table III as calculated from Equation (2) using the LAFs shown in Table II.

TABLE III
EFFECTIVE LOAD FACTORS

	A	B	C	D	E	F	G
Bio	0.85	0.85	0.8478	0.8588	0.8506	0.8765	0.848
LFG	0.76	0.76	0.7602	0.7703	0.7611	0.7843	0.759
Hydro	0.30	0.30	0.3017	0.3049	0.3008	0.3077	0.301
Wind	0.35	0.35	0.3520	0.3555	0.3509	0.3583	0.351
Tidal	0.28	0.28	0.2816	0.2844	0.2807	0.2866	0.281

The ELFs now credit the generators with extra energy output (i.e. $ELF_F^{LFG} = 0.7843$) and debit their energy output for increased losses (i.e. $ELF_G^{Biomass} = 0.8481$).

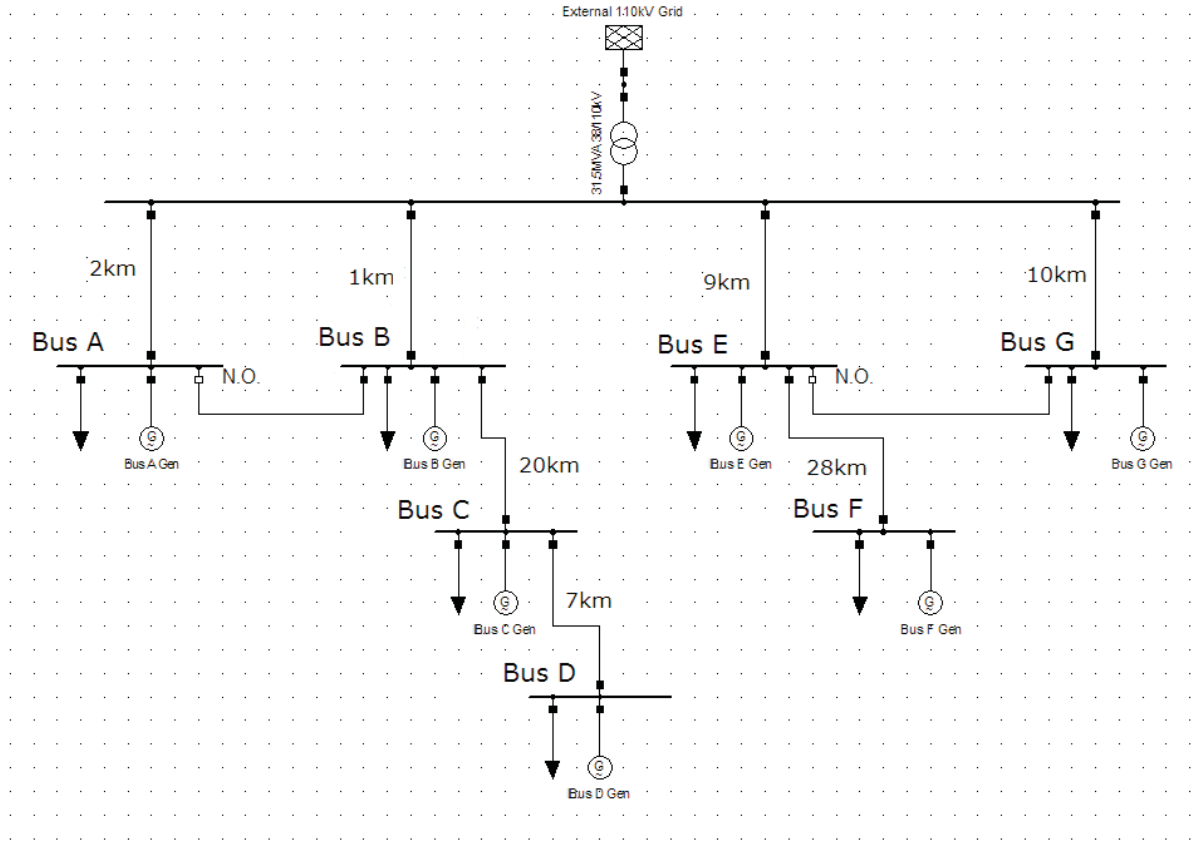

Fig. 1. 38kV 7 bus radial distribution network diagram

D. Available Energy Resources

Using the ELF's shown above in Table III the optimal DG plant mix is determined for two representative energy resource portfolios given in Tables V & VII. In each case P_{Opti} from Equation (4) is taken from Table IV. This table gives the optimal allocation for this section of network, which maximises the DG capacity subject to the relevant technical constraints using the methodology from [5]. The optimal DG plant mix is calculated in both cases using the objective function in (3) subject to the constraints given in equations (4), (5) and (6). The location constraints are imposed based on the geographical layout of the network in relation to the energy sources. The optimal plant mix is determined by the MILP algorithm from the commercially available software ILOG CPLEX with an absolute MIP gap tolerance of 1×10^{-6} . The connection losses are calculated for each energy resource portfolio and are shown for portfolios 1 & 2 in Tables IX & X respectively in the Appendix.

1) *Energy Resource Portfolio 1*: In this case an abundant energy resource is assumed as shown in Table V, with a number of wind and hydro sites along with the potential for a LFG and a biomass plant. The values shown for each energy resource are not cumulative, i.e. in the case of Wind 3, there is a 5.1MW wind resource that can be connected at bus 6 or 7, not a total Wind 3 resource of 10.2MW.

Using the calculated ELF's the optimal plant mix is determined and is shown in Table VI. The integer generation blocks

TABLE IV
OPTIMAL GENERATION CAPACITY ALLOCATION

Bus	Gen. (MW)
A	1.92
B	0
C	1.00
D	10.00
E	6.16
F	8.74
G	7.21
Total	35.03

are set to 20% in this case. The values shown are the products of $Plant_{ij}$ and $P_{avail_{ij}}$, which give the amount of each energy resource (j) to install at the i th bus. The total generation plant allocated is 33.90MW out of a possible 35.03MW. This allocation maximises the energy delivered from the available energy resources, through reduced average losses.

Due to the various constraints on the allocation, each energy resource cannot be allocated to the bus at which it has its maximum ELF. Values for the ELF's are given in Table III, however from Table V which is relatively sparse it can be seen that even for a diverse energy resource, a number of options are ruled out due to location constraints and with particular reference to Table IX, it is seen that there is a wide variation

TABLE V
ENERGY RESOURCE PORTFOLIO 1

	A	B	C	D	E	F	G
Bio	8.0	8.0	8.0	8.0	8.0	8.0	8.0
LFG	0	0	0	6.5	0	6.5	6.5
Hydro 1	2.0	2.0	0	0	2.0	0	0
Hydro 2	0	0	1.5	0	0	1.5	1.5
Hydro 3	0.6	0.6	0.6	0	0.6	0	0
Wind 1	0	0	0	4.5	4.5	4.5	4.5
Wind 2	0	8.5	8.5	8.5	8.5	0	0
Wind 3	0	0	0	0	0	5.1	5.1

TABLE VI
OPTIMAL PLANT MIX 1 (MW)

	A	B	C	D	E	F	G
Bio	0	0	0	0	0	8.0	0
LFG	0	0	0	6.5	0	0	0
Hydro 1	1.6	0	0	0	0	0	0
Hydro 2	0	0	0.6	0	0	0.6	0.3
Hydro 3	0.24	0	0.36	0	0	0	0
Wind 1	0	0	0	0	2.7	0	1.8
Wind 2	0	0	0	3.4	3.4	0	0
Wind 3	0	0	0	0	0	0	5.1

in the connection losses between each possible bus. As a result of this the 8.0MW biomass resource is allocated to bus G even though it has lower ELF at this bus than many others as can be seen in Table III. At the same time it can be seen that the Wind 2 resource is allocated between buses C & E, at which wind has its two highest ELF values.

2) *Energy Resource Portfolio 2:* In this portfolio the energy resource is not as diverse as in portfolio 1. There is a larger total energy resource, but it is in a few larger sources rather than a number of smaller sources. There is no potential LFG site and fewer hydro and wind sites. There is still potential for a biomass plant and there is now a tidal generation resource.

TABLE VII
ENERGY RESOURCE PORTFOLIO 2

	A	B	C	D	E	F	G
Bio	9.0	9.0	9.0	9.0	9.0	9.0	9.0
Hydro	4.3	4.3	0	0	0	0	0
Wind 1	0	0	0	5.2	5.2	5.2	5.2
Wind 2	0	0	7.8	7.8	7.8	0	0
Tidal	0	0	0	0	15.0	15.0	0

The optimal plant mix is determined for the new resource portfolio and is given in Table VIII. The generation is allocated in 20.00% integer blocks. In this case the total generation plant allocated is 32.88MW. This is less than in the first case, due to the more limited and less diverse energy resource.

Once again the impact of the constraints and ELFs can be

TABLE VIII
OPTIMAL PLANT MIX 2 (MW)

	A	B	C	D	E	F	G
Bio	0	0	0	0	0	0	7.2
Hydro	1.72	0	0	0	0	0	0
Wind 1	0	0	0	2.08	0	2.08	0
Wind 2	0	0	0	7.8	0	0	0
Tidal	0	0	0	0	6.0	6.0	0

seen on the plant mix determined. In particular, wind generation has a higher ELF at bus D and the Wind 1 & 2 resources connect 4.33MW and 1.3MW at that bus respectively.

VI. DISCUSSION

The optimal plant mixes shown in Tables VI and VIII are determined subject to the constraints outlined in Section IV. Of particular significance is the location constraint in Equation (5), the severity of this constraint has been determined by the geographical location of the buses and energy resources. Although a bus may be close enough that it is technically feasible to connect to it, if an energy resource is split between two buses, it may not be economically feasible to connect the generation to two buses. The inclusion of connection loss factors helps to avoid uneconomical allocations as the high losses incurred on the connecting line will make an allocation to a closer bus more likely. However, a detailed economical analysis of the factors influencing the feasibility of DG projects would be required to take proper account of these factors. In particular, the role that economies of scale would play, the projected revenues and the capital costs of a second or third connection.

It can be seen that the scope for optimisation of the plant mix is dependent on the level of diversity of the energy sources. Energy resource portfolio 1 is more diverse than energy resource portfolio 2 and it can be seen from the results that this facilitates the determination of a larger allocation of DG. It should be noted that the size of the allocation blocks will have a bearing on the solution determined, although an appropriate value can be chosen in each case depending on the size of the individual energy resources and the diversity of the energy resource. The objective of the optimisation is to maximise the total energy delivered from DG sources. As a result the methodology does not maximise each individual generator's revenue, but the total revenue generated from all the generators.

The two energy resources exceed the 35.03MW of permissible generation capacity from Table IV, however the MILP doesn't allocate enough generation plant to use all of this capacity. The formulation of the problem as a linear program would give a generation plant allocation of 35.03MW, however this plant allocation would consist of infeasibly small allocations. The formulation as an MILP gives a more realistic allocation of plant mix.

VII. CONCLUSION

A novel method for the calculation of loss adjustment factors for distributed generation has been presented. These LAFs take account of the average impact of different generation technologies at each bus on losses. The LAFs provide a pricing signal for the optimal DG plant mix, whereby generators' revenue will increase if they connect at the appropriate bus. These novel LAFs have been incorporated into an optimal plant mix methodology using MILP. This methodology determines the optimal DG plant mix for a section of distribution network subject to a number of constraints. The methodology is tested on two representative energy portfolios, in both cases performing well. Both cases demonstrate that there is significant scope for optimisation of the DG plant mix, to maximise both the revenue for the generators and the benefit to society.

APPENDIX

TABLE IX
CONNECTION LOSSES 1

	A	B	C	D	E	F	G
Bio	0.00066	0.0023	0.0327	0.0303	0.0281	0.0338	0.0727
LFG	0	0	0	0.0364	0	0.0433	0.1825
Hydro1	0.00010	0.0002	0	0	0.0085	0	0
Hydro2	0	0	0.0176	0	0	0.0123	0.0195
Hydro3	0.00012	0.0005	0.0161	0	0.0088	0	0
Wind1	0	0	0	0.0137	0.0067	0.0210	0.0101
Wind2	0	0.0013	0.0079	0.0043	0.0086	0	0
Wind3	0	0	0	0	0	0.0095	0.0150

TABLE X
CONNECTION LOSSES 2

	A	B	C	D	E	F	G
Bio	0.00066	0.0023	0.0327	0.0303	0.0281	0.0338	0.0727
Hydro	0.00008	0.0006	0	0	0	0	0
Wind1	0	0	0	0.0064	0.0133	0.0077	0.0491
Wind2	0	0	0.0023	0.0032	0.0053	0	0
Tidal	0	0	0	0	0.0085	0.0106	0

ACKNOWLEDGMENT

The authors gratefully acknowledge I. Codd, K. Niall, D. Phelan and T. Walsh of ESB Networks and their colleagues in the Electricity Research Centre for their help with this work.

REFERENCES

- [1] Directive 96/92/EC of the European Parliament and of the Council, "Concerning common rules for the internal market in electricity," of 19 December 1996. [Online]. Available: <http://www.europa.eu.int>

- [2] A. Collinson, G. K. Earp, D. Howson, R. D. Owen, and A. J. Wright, "The effect of increasing levels of embedded generation on the distribution network - ETSU K/EL/00184/REP," Available: www.dti.gov.uk, 1999.
- [3] Commission for Energy Regulation, "CER annual report 2004," 2004. [Online]. Available: <http://www.cer.ie/>
- [4] P. N. Vovos, G. Harrison, A. Wallace, and J. Bialek, "Optimal power flow as a tool for fault level-constrained network capacity analysis," *IEEE Trans. Power Syst.*, vol. 20, no. 2, pp. 734–741, May 2005.
- [5] A. Keane and M. O'Malley, "Optimal allocation of embedded generation on distribution networks," *IEEE Trans. Power Syst.*, vol. 20, no. 3, pp. 1640–1646, Aug. 2005.
- [6] A. Keane and M. O'Malley, "Impact of distributed generation capacity on losses," in *IEEE PES General Meeting*, Montreal, June 2006.
- [7] Commission for Energy Regulation, "Treatment of transmission and distribution losses," 2000. [Online]. Available: <http://www.cer.ie/cerdocs/cer0010.pdf>
- [8] J. R. Saenz, P. Eguia, J. L. Berastegui, J. Marin, and J. Arceluz, "Allocating distribution losses to customers using distribution loss factors," in *IEEE Powertech Conference*, Porto, Sept. 2001.
- [9] H. L. Willis, *Power Distribution Planning Reference Book*, 2nd ed. Marcel Dekker, New York, U.S.A., 2004.
- [10] (2005) ESB Networks infrastructure. [Online]. Available: <http://www.esb.ie/esbnetworks/>
- [11] (2005) ESB National Grid system information. [Online]. Available: <http://www.eirgrid.com/>
- [12] (2005) British Wind Energy Association. [Online]. Available: <http://www.bwea.com/energy/>
- [13] A. G. Bryans, P. Crossley, B. Fox, and M. O'Malley, "Impact of tidal generation on power system operation in Ireland," *IEEE Trans. Power Syst.*, vol. 20, no. 4, pp. 2034–2040, Nov. 2005.
- [14] (2005) ILOG CPLEX. [Online]. Available: <http://www.cplex.com>



Andrew Keane (S'04) received a B.E. degree in electrical engineering from University College Dublin in 2003. He is currently conducting research for a Ph. D. degree in the Electricity Research Centre, University College Dublin with research interests in power systems planning, distributed generation and distribution networks.



Mark O'Malley (S'86-M'87-SM'96) received B.E. and Ph. D. degrees from University College Dublin in 1983 and 1987, respectively. He is currently the Professor of Electrical Engineering at University College Dublin and director of the Electricity Research Centre with research interests in power systems, control theory and biomedical engineering.