



Title	Capability Chart for Distributed Reactive Power Resources
Authors(s)	Cuffe, Paul, Smith, Paul, Keane, Andrew
Publication date	2013-09-11
Publication information	Cuffe, Paul, Paul Smith, and Andrew Keane. "Capability Chart for Distributed Reactive Power Resources." Institute of Electrical and Electronics Engineers, September 11, 2013. https://doi.org/10.1109/TPWRS.2013.2279478 .
Publisher	Institute of Electrical and Electronics Engineers
Item record/more information	http://hdl.handle.net/10197/4729
Publisher's statement	© 2012 IEEE.
Publisher's version (DOI)	10.1109/TPWRS.2013.2279478

Downloaded 2026-05-02 00:30:15

The UCD community has made this article openly available. Please share how this access benefits you. Your story matters! (@ucd_oa)



© Some rights reserved. For more information

Capability Chart for Distributed Reactive Power Resources

Paul Cuffe, *Student Member IEEE*, Paul Smith *Member IEEE*, Andrew Keane, *Member IEEE*

Abstract—The ubiquity of synchronous generation should not be assumed in highly renewable power systems. Various problems may consequently arise: not least, the difficulties entailed in maintaining regional reactive power balance. Offering a potential solution to such problems, modern renewable generator technologies offer controllable reactive power resources. As many of these generators will be embedded in distribution networks, their incorporation into transmission system operational and planning activities appears challenging. An extension of the capability chart concept offers insight here: for a given active power exchange between the transmission system and a distribution network section, the range of controllable reactive power typically available is of interest. This aggregate capability depends on the innate machine capabilities of the distributed generators and on the prevailing conditions within the distribution network. Novel optimisation techniques are useful in addressing the latter point, offering a means to identify the combination of power flow profiles within the distribution system most restrictive to reactive power provision. The capability chart thus derived gives the dependable range of reactive power available, under the assumption that each generator is operated to locally maximise its own reactive power contribution. Such a description can be applied in transmission system planning, or to quantify the effects of modifications to the distribution system.

Index Terms-- distributed generation, voltage control, transmission planning, distribution planning, optimisation

I. INTRODUCTION

The increase of renewable generation on many power systems, and the corresponding displacement of synchronous plant, may lead at times to a paucity of ancillary service providers [1]. A number of challenges may thus be encountered, such as ensuring adequate synchronous inertia [2], ramping services [3], and maintaining regional reactive power balance [4]. This work speaks to this latter topic, taking distributed generators as a focus. By contrast with much of the extant literature on reactive power planning, which focuses on the siting and sizing of new dedicated resources [5], this work is aimed at an enhanced utilisation of the reactive power capabilities inherent in modern renewable generator technologies such as wind turbines [6].

The challenge of harnessing reactive power from distributed resources has been approached from a number of different perspectives. In [7], passive and active approaches for operating distributed generation are contrasted, with the minimisation of reactive power absorption from the

transmission system taken as the objective in either case. Other work, such as [8], has pointed out the value of decentralised control schemes, showing how autonomous voltage control for distributed generators may avoid local over-voltage constraints. Research such as [9] confirms the value of voltage-controlling renewable generators in maintaining system voltage stability. This value is reflected by the many grid codes internationally which demand voltage-controlling capabilities for large renewable generators [10].

A consensus emerges from the literature: utilisation of reactive power from renewable generators may be indispensable in lightly-synchronous power system regions. In consequence, transmission system planners will need to take proper account of all available reactive power sources, although techniques for assessing distribution-connected resources are not readily available in the literature. To address this, the present work will set out a novel methodology that gives a reactive power capability description for a generation-bearing distribution network. This description is given as a generalised capability chart [11], which shows the range of controllable reactive power available at the transmission node for any level of active power exchange with the distribution network.

Previous work [12] has used time-series techniques to provide a proxy to this capability chart. Novel optimisation techniques are proposed here as a more rigorous characterisation method. Typically, optimisation techniques for distribution networks have had such goals as to minimise network losses [13], or optimise generator siting [14]: the review in [15] shows the full range of problems that can be addressed. Beyond these applications, the use of optimisation techniques to determine resource *characterisations* rather than *optimised network settings* is suggested by [16], which used non-linear programming to delineate graphically the envelope of complex power loads a network section could serve. The key insight, that non-linear programming can operate as a *search technique* to find points of interest that are not necessarily optimal in the conventional sense of *desirability*, underpins the present work. The characterising role of optimisation techniques is further developed in [17], which also emphasises the value of capability charts in assessing a power system's ability to maintain reactive power balance. Drawing on these, and related sources [18-20], this work will show how optimisation techniques may be used to move beyond a description of *permissible* complex power flows, to the domain of *controllable* reactive power ranges. Using this innovative methodology, distributed reactive power resources can be given proper consideration in transmission system planning and operation activities.

In Section II the characterisation methodology is presented, being applied to a sample network described in Section III, for which results are provided in Section IV. The work concludes with Section V.

This work was conducted in the Electricity Research Centre, University College Dublin, Ireland, which is supported by the Commission for Energy Regulation, Bord Gáis Energy, Bord na Móna Energy, Cylon Controls, EirGrid, Electric Ireland, EPRI, ESB International, ESB Networks, Gaelectric, Intel, SSE Renewables, UTRC and Viridian Power & Energy.

P. Cuffe (paul.cuffe@ucd.ie) is funded through the SFI Research Frontiers Programme under grant number 09/RFP/ECE2394. P. Smith and A. Keane are funded through the Science Foundation Ireland (SFI) Charles Parsons Energy Research Awards.

II. METHODOLOGY FORMULATION

A. Characterisation Approach

The *dependable* reactive power capability of a network section is the range of reactive power control that will be available under even the worst network conditions. This capability is found by explicitly dispatching network variables that are naturally subject to uncontrolled variation, so the worst conditions that may arise are directly identified. This is performed iteratively: at each invocation, the AC Optimal Power Flow (OPF) tool serves a defined active power exchange between the distribution and transmission system. For each of these active power exchange levels, the AC OPF finds the combination of load and generator operating points that could maximally hinder reactive power import or export. This unusual form of optimal dispatch is the central component of the characterisation methodology.

Previous work in [12, 21] offers deeper discussion of how generators and loads interact to affect the aggregate level of reactive power support available: a key result is that the prevailing voltage profile within the distribution network is of central importance.

This work does not consider centralised management techniques that control distributed generators in real-time to achieve maximum reactive power support at the transmission level. Rather, a more modest, readily-implementable control scheme is assumed, where each voltage-controlling generator maximises its own reactive power contribution, under local machine and voltage limits.

The aggregate reactive power capability of a network operated in this simpler manner is the subject of the characterisation methodology. The implementation of this control scheme is not given explicit consideration here, and it is assumed that the voltage-controlling generators do not exhibit undesirable interaction. Modulating the reactive power behaviour of the network will require a reissuing of voltage set-points to each generator: the potential effect of this on active power losses is a cost that is not considered in the present work.

B. Optimal Power Flow Framework

This work draws on the custom AC OPF tool more fully described in [22]: at the heart of the model are the archetypal power flow equations for π -equivalent medium length lines. This formulation gives explicit representation to voltage magnitudes and angles, and is thus appropriate for modelling distribution systems, where line resistances are non-negligible. The AC OPF tool's suitability for the present role has been initially validated in [21], which compared capability characterisations from time-series simulations with those derived through the optimisation methodology.

C. Objective Function

Each invocation of the tool defines a key constraint parameter: p_{net} , the level of active power exchange with the transmission system. Individual generator and load levels, p_g and p_l , are the decision variables controlled to satisfy this constraint. Note that generator reactive power regimes, q_g , are not subject to free dispatch within the optimisation, but instead are constrained to model voltage-controlling behaviour at each

generator bus. The minimisation of reactive power exchange, q_{net} , is the objective function.

$$\min(\pm q_{net}) \quad (1)$$

This technique may be described as a *worst-best* search: with each generator doing its local *best* to provide reactive power, the dependable level of aggregate support is determined by the most onerous (*worst*) combination of network power flows that may arise.

A full reactive power resource description will delineate anticipated levels of injecting and absorbing reactive power support, to give both portions of the capability chart. Dependable reactive power export from the distribution network is characterised by setting each generator to regulate to its upper voltage limit, and optimising to minimise the reactive power injection to the external grid by selecting $+q_{net}$ in (1). Each generator's reactive power contribution is maximised under this voltage-controller assumption, where all available voltage headroom is utilised for the export of reactive power. Conversely, the dependable levels of reactive power absorption are found by setting each generator to regulate to its lower voltage limit, and minimising reactive power absorption from the external grid using $-q_{net}$ in (1).

Beyond a description of the network's dependable capability, the objective function can be selected to maximise reactive power export or import, to show the peak reactive power capability. This *contingent* capability is the range of reactive power which is only available under the most favourable of network conditions.

D. Generator Voltage Control

An essential addition to the AC OPF tool is the implementation of voltage-controlling functionality for distributed generators. This is realised by imposing a constraint on the reactive power regime, q , of each generator g , to control the voltage at bus b :

$$q_g \propto (V_{bg} - V_{setg}) \quad (2)$$

An appropriately large constant of proportionality in (2) will invoke a reactive power regime that brings the generator's voltage error signal close to zero, ensuring the voltage magnitude at the generator's controlled bus, V_b , is at the specified setting of V_{set} . This formulation finds the equilibrium point which will be achieved by an idealised voltage controller with 0% droop.

As each generator operates subject to machine limits, the reactive power regime is bounded by:

$$q_g^- \leq q_g \leq q_g^+ \quad (3)$$

where the prevailing reactive power limits, q_g^- and q_g^+ , depend on each generator's machine characteristics and active power operating point. Attenuation of available reactive power at low active power outputs can be anticipated for wind farms based on doubly fed induction generator technology [6]. Such a machine capability is modelled with the appropriate portion of a sigmoid function which relates active power output, p_g , to the prevailing q_g limits. For example, the export limit is given by:

$$q_g^+ \propto \left(\frac{1}{1 + e^{-a_g p_g}} - 0.5 \right) \quad (4)$$

where the constant of proportionality and the a_g coefficient are selected appropriately to model the generator's reactive power capability, as shown in Fig. 1.

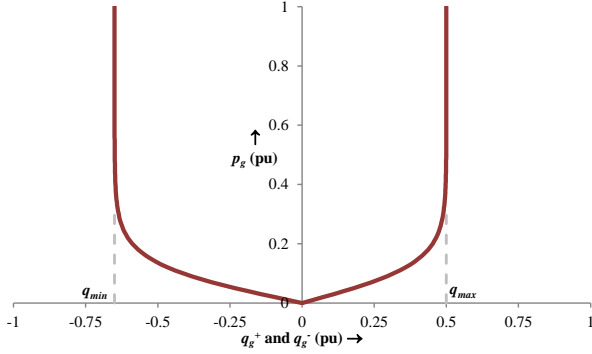

Fig. 1 Sigmoidal relationship between a generator's reactive power machine limits, q_g^+ and q_g^- , and active power output, p_g .

E. Transformer Voltage Control

To consider the effect of transformer voltage control, the AC OPF tool was augmented with a tap-changer model. To avoid mixed-integer programming, the transformer voltage ratio was taken as a continuous variable, bounded by upper and lower tap limits. The transformer also includes a line drop compensation (LDC) model [23], where the voltage set-point, V_{set} , for each transformer, t , is modified by the power flow through the transformer, P and Q , and the prevailing low-side voltage, V_{lo} :

$$V_{set_t} = V_{nom_t} + \frac{(R_{LDC_t}P_t) + (X_{LDC_t}Q_t)}{V_{lo_t}} \quad (5)$$

Where R_{LDC} and X_{LDC} are the line drop compensator's internal resistance and reactance: setting these to 0 Ω disables line drop compensation. V_{nom} is the nominal voltage setting.

F. Load and Generator Variance Constraint

Due to meteorological considerations, it is intuitive to assume that adjacent wind or photovoltaic generators will display some correspondence between their active power outputs. Equally, neighbouring loads will exhibit correlation. As such, widely unequal load and generation power flow regimes across the distribution system are not to be anticipated in practice. Their exclusion from the optimisation search space is therefore appropriate.

A number of statistical formulations may be used to quantify the correspondence between adjacent generators and loads. Multivariate autoregressive techniques have been used in [24] to probe the relationships between wind power outputs in different power system zones, while load has often been considered in terms of diversity factors [25]. In contrast to these techniques, previous work by the authors [21] has shown that load and generator variance can be restrained in a realistic way by adding a standard deviation constraint to the deterministic AC OPF framework:

$$\sigma(p_g) \leq \sigma_g^+ \quad (6)$$

$$\sigma(p_l) \leq \sigma_l^+ \quad (7)$$

The imposition of a maximum bound on the standard deviations of the two populations, p_g and p_l , being normalised generator outputs and load levels, respectively, enforces a

degree of uniformity on network power flow profiles. This constraint excludes the widely disparate power flow profiles which are often most restrictive of reactive power provision. Additionally, the restriction of the feasible region enforced by this constraint aids the tractability of the optimisation problem.

Note that the normalised load standard deviation, $\sigma(p_l)$, is calculated such that 0 corresponds to the load's minimum level. The constraining parameters, σ_g^+ and σ_l^+ , are selected based on anticipated network behaviour.

G. Generator Connection Point Voltage Bounds

Each generator must control its terminal voltage to a value that maintains downstream voltages within acceptable limits. Appropriate voltage bounds can be determined from two snapshot load flow analyses of the network. Maximum load levels and minimum generation outputs gives the worst voltage drop to be anticipated for each radial line. Conversely, maximum generator output and minimum load captures the highest voltage rise expected. A generator's upper voltage limit, V_g^+ , will be the legal upper limit minus the worst downstream voltage rise, while the lower limit, V_g^- , must be the lower legal limit plus the downstream voltage drop. With each generator operating within these bounds, acceptable downstream voltages are assured even without supervisory systems. Recall that this voltage controller framework means that each generator will provide its own maximal contribution to reactive power support, until it is restricted by a voltage limit or its own machine limits.

H. Iterative Resource Characterisation

The optimisation problem is solved repeatedly to give the capability description. Each invocation of the AC OPF tool will have a different active power exchange, p_{net} , imposed at the defined export bus: the corresponding minimised reactive power support is recorded on successfully achieving an optimal solution. This iterative process, presented diagrammatically in Fig. 2, gives the aggregated capability description to an arbitrary granularity. A fine-grained capability description is helpful if the solver fails to achieve a satisfactory solution, as a data point can be excluded and the capability description interpolated from adjacent points.

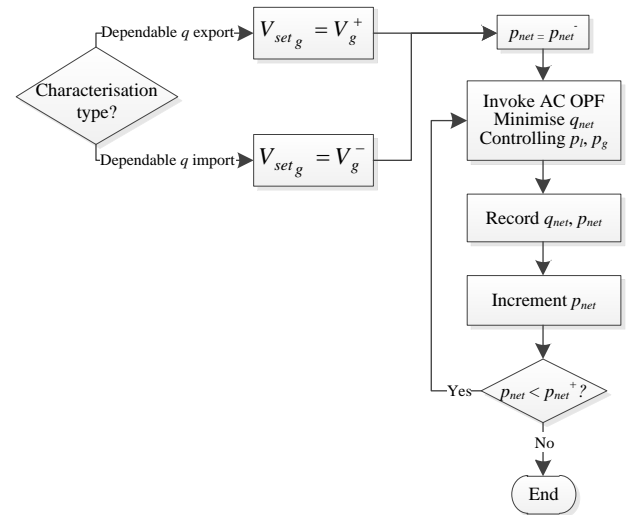

Fig. 2 Process description of the iterative characterisation methodology.

The process description in Fig. 2 shows how both sides of the capability chart are derived; recall that if generators are set to regulate to their maximum permissible voltage, the network's dependable level of reactive power export is characterised, and *vice versa*. With generator voltage set-points fixed, the iterative process commences, starting at the lowest level of active power exchange that is feasible for the network, p_{net}^- , being the maximum load and minimum generation condition. Iteration continues until the maximum feasible export, p_{net}^+ , is reached.

III. TEST PLATFORM

A. Test Network

The UK Generic Distribution System EHV 1 [26], shown in Fig. 3, was selected as a test platform to demonstrate the characterisation methodology. This system is a 33 kV rural network with a maximum loading of 22.8 MW, making it representative of the class of network often used to connect wind generation.

A number of modifications were made to the system: most significantly, four wind farm generators, of realistically diverse capacities and reactive power capabilities (per Table IV), were added, totalling 51.5 MW of export capacity. This substantial level of generation capacity means the network operates over a wide range of active power exchange levels with the transmission system, with a maximum import of ~ 23 MW and a maximum export of ~ 30 MW. The reactive power performance of the network under widely differing active power regimes can thus be examined. To accommodate the desired penetration levels of distributed generation, line impedances are reduced by 40% (per Table III) to mimic a more compact network, and the thermal rating of the bulk supply transformer is relaxed. Wind farm connection points in the network were selected to represent various electrical distances between the export bus and the generator; as such, the location-dependant effects of voltage headroom limits are made manifest. Other minor consolidations were also made to the network; full details of the modified system are given in the Appendix. Generator voltage bounds are given in Table I, calculated using worst-case downstream voltage rise and drop for each generator.

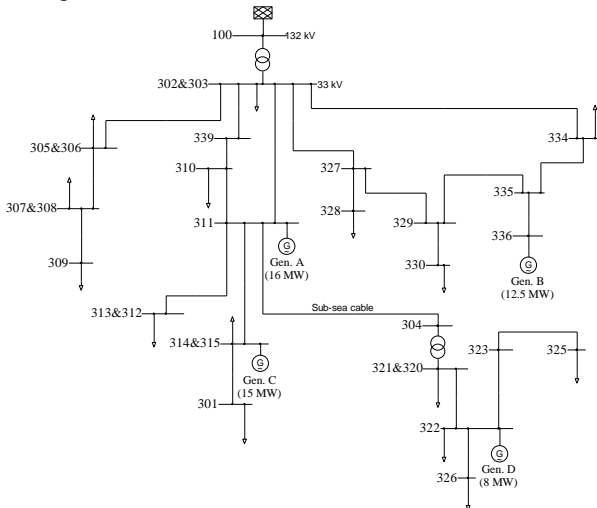

Fig. 3 Modified UK generic distribution system EHV1.

Loads in the system operate with a fixed power factor and a constant-power ZIP model. Load profile data provided with the test system allows minimum and maximum load levels to be inferred (see Table II) The system is coupled to the 132 kV transmission system through a tap-changing transformer, which maintains the *sending voltage* at the nominal 1 pu value of 33 kV. A modification to this regime is imposed in Section IV. B. , where line drop compensation is enabled.

The transmission system bus, labelled 100, is taken as the export bus, where p_{net} is imposed and q_{net} recorded. Voltage limits on the system are tight, between 0.97 pu and 1.03 pu, and a booster transformer at the remote end of the sub-sea cable is necessary to avoid downstream under-voltage breaches.

TABLE I
GENERATOR VOLTAGE LIMITS

	V_g^- (pu)	V_g^+ (pu)
Gen. A	0.984	1.030
Gen. B	0.970	1.030
Gen. C	0.973	1.030
Gen. D	0.975	1.030

The test system is described as a small rural network, so a close correspondence between adjacent generators and loads can be anticipated. Drawing on analysis of similar networks in [21], a maximum standard deviation level of 0.15 was selected as a reasonable value for σ_g^+ and σ_l^+ . Other network configurations, and generation technologies, may call for quite different figures for σ_g^+ and σ_l^+ : the present value is given only to demonstrate the characterisation methodology.

B. Optimisation Environment

The AC OPF tool was formulated within the AIMMS [27] environment, and CONOPT 3.14V was selected as the most suitable solver after trialling various alternatives. A granularity of 0.5 MW was selected to produce the characterisations: the active power exchange at the transmission bus was incremented by this value each time the solver was invoked.

IV. RESULTS & DISCUSSION

The iterative characterisation methodology was applied to the test network, to give a graphical description of the aggregate reactive power capability of this network section. Four runs of the characterisation methodology were executed. With generators regulating to V_g^+ , not only was the minimisation of reactive power export performed to give the '*dependable*' description, but the maximisation case was also recorded, giving the '*contingent*' capability. Corresponding characterisations were performed with generators regulating to V_g^- , giving both sides of the capability chart.

A. Network Characterisation

The results of the characterisation are provided in Fig. 4, which gives a graphical description of the network's anticipated reactive power performance. Here, the focus of the chart is the inner lines, being the '*dependable*' reactive power capability of the network. Additionally, the outer lines show the '*contingent*' level of reactive power support that would be

available under the most favourable conditions. The axes in Fig. 4, and elsewhere, are such that positive figures represent a power export to the transmission system.

Note that successful invocations of the AC OPF tool were not achieved universally: this would be anticipated given the scale of the problem and the nature of non-linear programming. Over the four runs of the characterisation methodology, 432 separate optimisations were invoked, of which 46 were discarded as outliers from the curve described by adjacent optimal points.

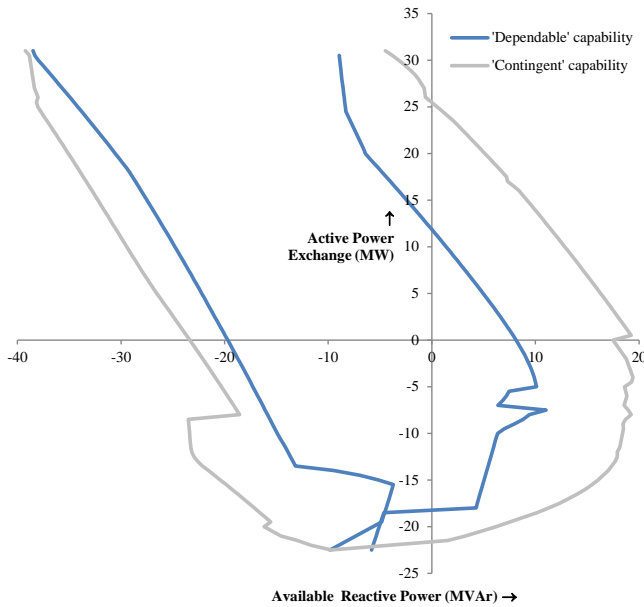

Fig. 4 Reactive power capability of the test network.

Two key ideas are evident in Fig. 4: reactive power support available at the transmission node is determined by both the active power exchange level, and by the internal state of the distribution system. The variation of each trace along the vertical axis supports the first assertion. The second claim is supported by comparing the traces for the *'dependable'* and *'contingent'* capabilities: on the export side of the graph, they diverge by up to 10 MVar.

To better understand the importance of the network's active power exchange level, consider the shape of the *'dependable'* capability chart. The most noticeable feature is the sloping of the traces: as active power exports from the networks rise, less reactive power can be exported, and more can be absorbed. This is a direct consequence of the electrical distance between the generators and the transmission node. Two related factors are at play: generator active power exports raise connection point voltages, leaving less voltage headroom available for reactive power export, while also increasing I^2X losses.

Other features are evident in the shape of the *'dependable'* capability. There is a narrowing of the controllable reactive power range for active power inflows beneath the -7 MW level. This is a consequence of each generator's sigmoidal machine capability (recall Fig. 1); generator outputs are necessarily minimal in this region of the chart, so machine limits become restrictive. Further to this, the inner traces converge around the -16 MW level. These active power exchange levels can be realised with all generator outputs at 0 MW: as such, no voltage controllers are in effect, and the

reactive power behaviour reflects the fixed power factor operation of the network's loads.

The converse of these effects is seen in the upper portion of the chart: note the *'dependable'* reactive power export trace flattening toward the vertical above the 20 MW level. These high levels of active power export can only be encountered at times of low loading. As such, consumption of reactive power by the inductive loads is reduced, benefiting the net export of reactive power.

1) Underlying Generator Behaviour

It emerges from Fig. 4, and subsequent discussion, that the characterisation methodology produces an intricate capability description which displays numerous complex features. To probe the interplay of factors underlying the derived capability, Fig. 5 examines the controlled dispatch of the distributed generators which gave the *'dependable'* export trace in Fig. 4.

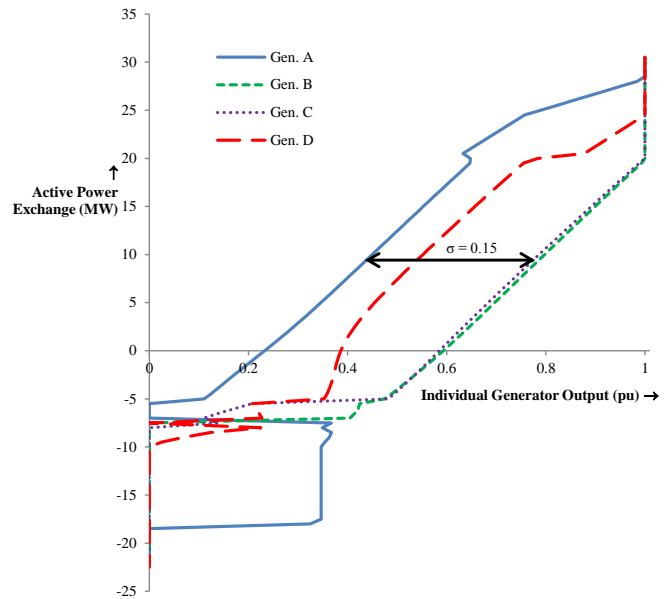

Fig. 5 Individual generator outputs, as controlled to minimise reactive power export.

The complexity of the characterisation problem is well illustrated by Fig. 5, which is plotted against the same vertical axis as Fig. 4. It shows the normalised power output for each generator that was found to be most restrictive of total reactive power export, with each generator regulating its voltage to V_g^+ . It is evident that the generator output combinations which align to hinder reactive power export do not follow clear patterns. This emphasises the characterisation problem's intractability to directly analytic approaches.

One portion of Fig. 5 is reasonably linear: between the -5 MW and 20 MW active power exchange levels. Here, the tendency to source the greatest proportion of the total generation requirement from *Gens. B & C* is made clear: their traces overlay each other at the right of the graph. This tendency corresponds with intuition: both generators are electrically distant from the sending bus, so their active power export will cause maximal voltage rise, leaving less headroom available for reactive power export. Indeed, recalling Fig. 4, above 14 MW reactive power imports are needed to maintain

generator voltages at V_g^+ .

The effect of the standard deviation constraint is suggested by the arrow in Fig. 5. Without this constraint, *Gens. B & C* could be controlled to their full active power output while leaving *Gens. A & D* at zero output. This unrealistic search methodology would give an overly pessimistic view of the network's reactive power capability.

To explore localised generator effects, Fig. 6 unbundles each trace in Fig. 5, showing the underlying active and reactive power behaviour of each generator across each iteration of the characterisation methodology.

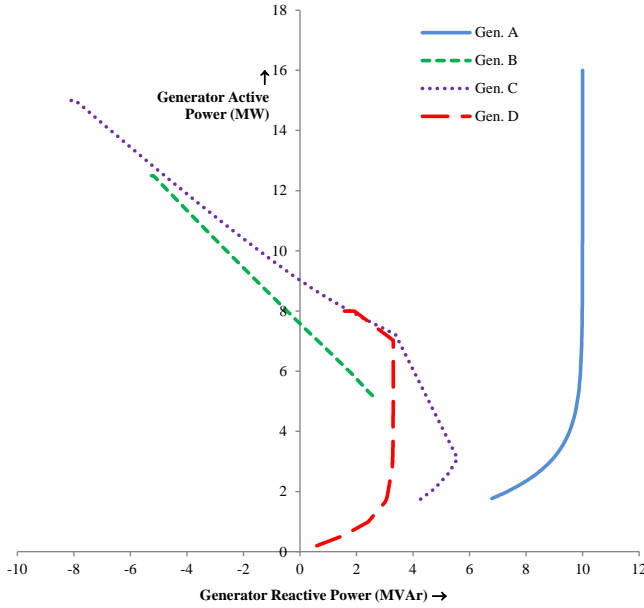

Fig. 6 Generator active and reactive power relationships underlying the dependable reactive power export characterisation.

It is apparent from Fig. 6 that *Gen. A* does not encounter voltage constraints even under the worst network conditions found; the voltage-control regime follows its sigmoidal machine export limits. This is permitted by its position in the network, which is electrically close to the export node.

Conversely, local voltage effects on *Gens. B & C* preclude them from exporting the full reactive power available from their innate machine capabilities, with reactive power import required to maintain their V_g^+ voltage at times of high active power output. Finally, *Gen. D* generally operates along its full machine capability, though the voltage rise attending higher active output levels demands a curtailed reactive power regime to maintain its voltage at the V_g^+ value.

The complement of Fig. 6 is provided in Fig. 7, showing the effect of voltage and machine limits underlying the dependable reactive power absorption characterisation, where each generator regulates to its V_g^- value.

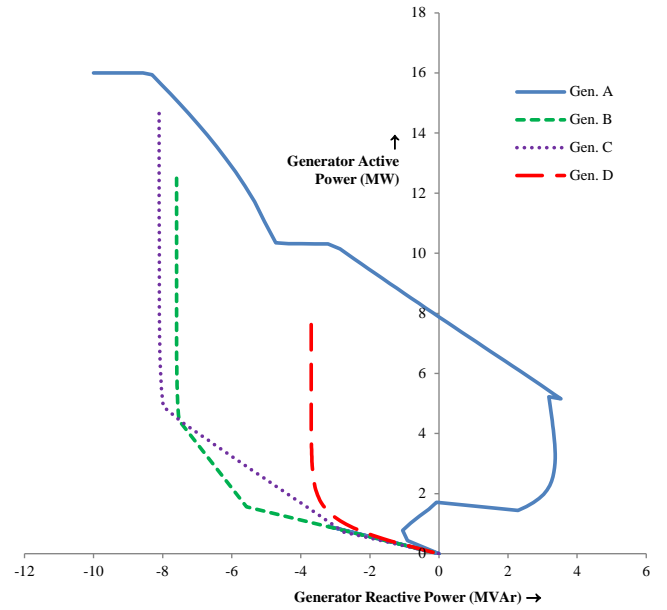

Fig. 7 Generator active and reactive power relationships underlying the dependable reactive power import characterisation.

It is apparent in Fig. 7 that *Gen. A* is the most constrained generator. Recalling Table I, *Gen. A*'s location in the centre of the network, with substantial downstream loads, means that its minimum permissible voltage is the highest of the generators, at 32.46 kV. This voltage setting does not invoke as great an import of reactive power, and so *Gen. A* operates over a range of reactive power regimes. The remaining generators, with lower V_g^- settings, generally absorb the maximum reactive power permitted by their machine capabilities.

B. Modified Network Operation

1) Proposed Network Modification

The principal determinant of the voltage profile within the distribution system is the tap setting of the bulk supply point transformer. The literature illustrates how dynamic control of distribution system sending voltage can be of benefit in integrating distribution generation [28], and novel use of line drop compensation (LDC) has been proposed in this regard [29]. An appropriate LDC resistance value will lower the sending voltage when active power is being exported, and will raise it under import conditions. This increases voltage headroom, which can be viewed as an increase in network hosting capacity or as a boost in export capacity for reactive power. The characterisation methodology can be utilised to quantify this latter benefit, giving a tangible metric of the improved reactive power capability achieved.

2) Modified Network Characterisation

For the purpose of exposition, the test system was modified by enabling line drop compensation of the nominal 1 pu sending voltage. A value of 0.022Ω for R_{LDC} was selected by trial-and-error as suitable to gain some improvement in voltage headroom; the rigorous derivation of such a figure is beyond the scope of the present demonstration. The sending voltage ranged between 0.979 pu for maximum active power exports, and 1.015 pu for maximum loading conditions.

The effects of this modification are presented in Fig. 8.

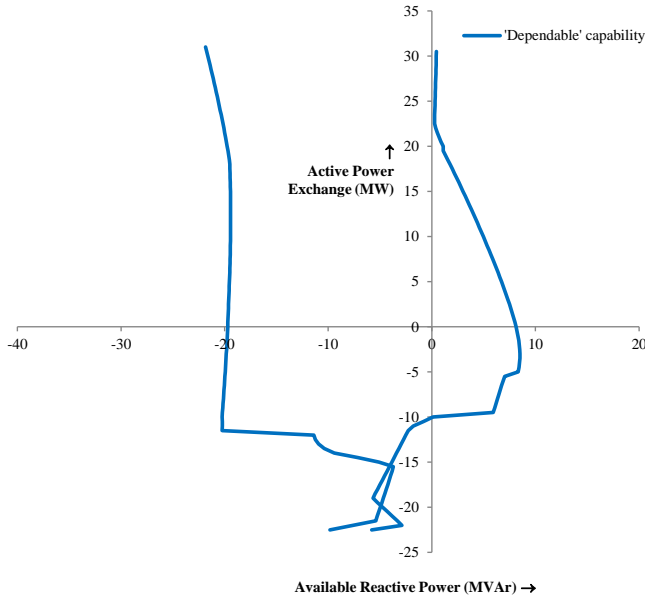

Fig. 8 Reactive power capability of the test network, where LDC is enabled

The effect of even conservative LDC settings is keenly illustrated by comparing Fig. 8 with Fig. 4. As expected, the generally lower distribution system voltages serve to ease the over-voltage limits illustrated previously in Fig. 6, which permits greater dependable reactive power export. This scheme permits operation of the network at a unity power factor under all network conditions: without LDC, high active power exports necessitated import of reactive power to satisfy internal voltage limits. Conversely, the modified sending voltage regime makes under-voltage limits more onerous to reactive power absorption at high active power outputs. For this reason, the dependable importing support of the network plateaus at a level of 20 MVar absorbed. Such phenomena are given explicit representation by the characterisation methodology, and thus the full effects of a modified network operational regime can be quantified.

V. CONCLUSIONS

It has been demonstrated that non-linear programming can be used as an effective search technique to give resource descriptions of distributed reactive power resources in the form of an aggregated capability chart. Two novel additions to the typical AC OPF implementation permit this: a voltage-control mode for generators, and an objective function which minimises aggregate reactive power support.

Reactive power capability descriptions can offer useful insight when planning for voltage security in power system regions dominated by distributed generation. Future work may consider improved unit commitment and dispatch regimes: many power systems adopt operational policies that constrain on a certain number of synchronous units in each power system region to ensure maintenance of reactive power balance. Regional reactive power margins, taking the summation of available transmission and distributed resources, may be a better indicator of voltage security in unit commitment formulations, and may improve the optimality of commitment schedules by obviating must-run constraints.

The characterisation methodology provides a general purpose technique for assessing the contribution diverse distributed resources may make to voltage support at the transmission level. Emerging sources of reactive power can thus be quantified from the transmission system perspective in terms comparable to that of a synchronous machine.

APPENDIX MODIFIED UK GDS EHV 1 TEST SYSTEM PARAMETERS

TABLE II: LOAD PARAMETERS

Bus	p_{max} (MW)	p_{min} (MW)	pf (ind)
301	1.14	0.76	0.980
302&303	0.9	0.6	0.981
305&306	0.168	0.112	0.978
307&308	0.192	0.128	0.983
309	1.986	1.324	0.980
310	1.158	0.772	0.980
313&312	11.04	7.36	0.980
314&315	1.14	0.76	0.980
321&320	0.33	0.22	0.981
325	0.462	0.308	0.982
322	1.62	1.08	0.980
326	1.71	1.14	0.980
328	0.48	0.32	0.981
330	0.126	0.084	0.982
334	0.348	0.232	0.979

TABLE III: LINE PARAMETERS

Start bus	End bus	R_l (Ω)	X_l (Ω)
314&315	301	2.57	2.27
311	302&303	1.20	1.94
302&303	327	1.39	1.86
334	302&303	3.31	2.69
302&303	339	0.65	1.47
305&306	302&303	0.84	0.61
305&306	307&308	0.37	0.27
309	307&308	3.31	2.44
311	304	2.88	2.56
311	310	1.41	1.88
311	313&312	0.10	0.09
311	314&315	3.38	2.46
322	321&320	3.52	4.79
322	326	6.17	4.29
323	322	7.36	5.70
325	323	3.03	2.20
327	328	0.35	0.15
327	329	0.61	0.72
329	330	0.25	0.25
329	335	1.12	1.12
335	334	2.61	1.90
335	336	2.62	1.91
339	310	0.64	1.44

TABLE IV: GENERATOR PARAMETERS

Generator	p_{max} (MW)	q_{min} (MVar)	q_{max} (MVar)	Sigmoid α
Gen. A	16	-10.0	10.0	-15
Gen. B	12.5	-7.6	6.7	-15
Gen. C	15	-8.1	6.1	-15
Gen. D	8	-3.7	3.3	-15

REFERENCES

- [1] "Facilitation of Renewables WP3 Final Report," EirGrid Plc. June 2010.
- [2] L. Rutledge and D. Flynn, "System-wide inertial response from fixed speed and variable speed wind turbines," in *Power and Energy Society General Meeting, 2011 IEEE*, 2011, pp. 1-7.
- [3] E. Lannoye, D. Flynn, and M. O'Malley, "Evaluation of Power System Flexibility," *Power Systems, IEEE Transactions on*, vol. 27, pp. 922-931, 2012.
- [4] V. Akhmatov and P. B. Eriksen, "A Large Wind Power System in Almost Island Operation - A Danish Case Study," *Power Systems, IEEE Transactions on*, vol. 22, pp. 937-943, 2007.
- [5] Z. Wenjuan, L. Fangxing, and L. M. Tolbert, "Review of Reactive Power Planning: Objectives, Constraints, and Algorithms," *Power Systems, IEEE Transactions on*, vol. 22, pp. 2177-2186, 2007.
- [6] S. Engelhardt, I. Erlich, C. Feltes, J. Kretschmann, and F. Shewarega, "Reactive Power Capability of Wind Turbines Based on Doubly Fed Induction Generators," *Energy Conversion, IEEE Transactions on*, vol. 26, pp. 364-372, 2011.
- [7] L. F. Ochoa, A. Keane, and G. P. Harrison, "Minimizing the Reactive Support for Distributed Generation: Enhanced Passive Operation and Smart Distribution Networks," *Power Systems, IEEE Transactions on*, vol. 26, pp. 2134-2142, 2011.
- [8] T. Sansawatt, L. F. Ochoa, and G. P. Harrison, "Integrating distributed generation using decentralised voltage regulation," in *Power and Energy Society General Meeting, 2010 IEEE*, 2010, pp. 1-6.
- [9] E. Vittal, M. O'Malley, and A. Keane, "A Steady-State Voltage Stability Analysis of Power Systems With High Penetrations of Wind," *Power Systems, IEEE Transactions on*, vol. 25, pp. 433-442, 2010.
- [10] M. Tsili and S. Papathanassiou, "A review of grid code technical requirements for wind farms," *Renewable Power Generation, IET*, vol. 3, pp. 308-332, 2009.
- [11] S. M. Abdelkader and D. Flynn, "Graphical determination of network limits for wind power integration," *Generation, Transmission & Distribution, IET*, vol. 3, pp. 841-849, 2009.
- [12] P. Cuffe, P. Smith, and A. Keane, "Transmission System Impact of Wind Energy Harvesting Networks," *Sustainable Energy, IEEE Transactions on* 2012 doi: 10.1109/tste.2012.2199342.
- [13] L. F. Ochoa and G. P. Harrison, "Minimizing Energy Losses: Optimal Accommodation and Smart Operation of Renewable Distributed Generation," *Power Systems, IEEE Transactions on*, vol. 26, pp. 198-205, 2011.
- [14] G. Celli, E. Ghiani, S. Mocci, and F. Pilo, "A multiobjective evolutionary algorithm for the sizing and siting of distributed generation," *Power Systems, IEEE Transactions on*, vol. 20, pp. 750-757, 2005.
- [15] L. F. Ochoa and G. P. Harrison, "Using AC Optimal Power Flow for DG planning and optimisation," in *Power and Energy Society General Meeting, 2010 IEEE*, 2010, pp. 1-7.
- [16] E. Chiodo, A. Losi, R. Mongelluzzo, and F. Rossi, "Capability chart for electrical power systems," *Generation, Transmission and Distribution, IEE Proceedings C*, vol. 139, pp. 71-75, 1992.
- [17] A. Losi, F. Rossi, M. Russo, and P. Verde, "New tool for reactive power planning," *Generation, Transmission and Distribution, IEE Proceedings C*, vol. 140, pp. 256-262, 1993.
- [18] A. Losi, V. Mangoni, and M. Russo, "Optimal exploitation of generator-transformer units," *Energy Conversion, IEEE Transactions on*, vol. 13, pp. 90-95, 1998.
- [19] A. Losi, F. Rossi, M. Russo, and P. Verde, "Capability chart for the planning of reactive power sources," in *Electrotechnical Conference, 1996. MELECON '96., 8th Mediterranean*, 1996, pp. 845-849 vol.2.
- [20] A. Losi, M. Russo, P. Verde, and D. Menniti, "Capability chart for generator-transformer units," in *Electrotechnical Conference, 1996. MELECON '96., 8th Mediterranean*, 1996, pp. 1580-1583 vol.3.
- [21] P. Cuffe, P. Smith, and A. Keane, "Characterisation of the Reactive Power Capability of Diverse Distributed Generators: Toward an Optimisation Approach," in *IEEE Power and Energy Society General Meeting*, San Diego, CA, USA, 2012.
- [22] M. Džamarija, M. Bakhtvar, and A. Keane, "Operational Characteristics of Non-firm Wind Generation in Distribution Networks," in *IEEE Power and Energy Society General Meeting*, San Diego, CA, USA, 2012.
- [23] M. H. J. H. Bollen, F. *Integration of Distributed Generation in the Power System*. Hoboken, New Jersey: IEEE, 2011.
- [24] M. S. Miranda and R. W. Dunn, "Spatially Correlated Wind Speed Modelling for Generation Adequacy Studies in the UK," in *Power Engineering Society General Meeting, 2007. IEEE*, 2007, pp. 1-6.
- [25] V. P. Chatlani, D. J. Tylavsky, D. C. Montgomery, and M. Dyer, "Statistical Properties of Diversity Factors for Probabilistic Loading of Distribution Transformers," in *Power Symposium, 2007. NAPS '07. 39th North American*, 2007, pp. 555-561.
- [26] SEDG. *United Kingdom Generic Distribution System EHV 1*. Available: <http://www.sedg.ac.uk/>
- [27] M. Roelofs and J. Bisschop, *AIMMS - The User's Guide.*: Paragon Decision Technology, 2011.
- [28] M. Jacxsens, B. Meersman, T. L. Vandoorn, J. D. M. De Kooning, and L. Vandeveldel, "Overview of voltage control strategies in medium voltage networks with implementation of distributed generation," in *Renewable Power Generation (RPG 2011), IET Conference on*, 2011, pp. 1-6.
- [29] F. A. Viawan, A. Sannino, and J. Daalder, "Voltage control with on-load tap changers in medium voltage feeders in presence of distributed generation," *Electric Power Systems Research*, vol. 77, pp. 1314-1322, 2007.



Paul Cuffe received the BE (Electrical) in 2009. He is currently pursuing a PhD in the Electricity Research Centre, University College Dublin (UCD), Ireland. His research interests are voltage control techniques for distributed networks with significant renewable penetration.



Paul Smith is a SFI Charles Parsons Award Researcher in the Electricity Research Centre, UCD, Ireland. He graduated with BE and MIE degrees from UCD and spent over 35 years in the electricity industry dealing with system planning and operations issues. He is a Distinguished Member of CIGRÉ and an invited expert member of the CIGRÉ Study Committee on System Development and Economics.



Andrew Keane received B.E. and Ph.D. degrees in Electrical Engineering from University College Dublin in 2003 and 2007 respectively. He is a lecturer with the School of Electrical, Electronic and Communications Engineering, UCD, Ireland, with research interests in power systems planning and operation, distributed energy resources and distribution networks.