



Title	Resiliency oriented integration of Distributed Series Reactors in transmission networks
Authors(s)	Soroudi, Alireza, Maghouli, Pourya, Keane, Andrew
Publication date	2017
Publication information	Soroudi, Alireza, Pourya Maghouli, and Andrew Keane. "Resiliency Oriented Integration of Distributed Series Reactors in Transmission Networks." IET, 2017. https://doi.org/10.1049/iet-gtd.2016.1536 .
Publisher	IET
Item record/more information	http://hdl.handle.net/10197/8519
Publisher's statement	This paper is a postprint of a paper submitted to and accepted for publication in IET Generation, Transmission and Distribution and is subject to Institution of Engineering and Technology Copyright. The copy of record is available at the IET Digital Library.
Publisher's version (DOI)	10.1049/iet-gtd.2016.1536

Downloaded 2026-05-02 01:12:22

The UCD community has made this article openly available. Please share how this access benefits you. Your story matters! (@ucd_oa)



© Some rights reserved. For more information

Resiliency oriented integration of Distributed Series Reactors in transmission networks

Alireza Soroudi, Pouria Maghouli*, Andrew Keane

Abstract

Secure and reliable operation of power system in normal and contingency conditions is of great importance for system operator. Natural disasters can seriously threaten power systems normal operation with catastrophic consequences. While hardening approaches may be considered for resiliency improvement, an application of a new and cost effective technology is proposed in this paper. This work proposes a planning procedure for integrating Distributed Series Reactors (DSR) into transmission grids for improving the resiliency against these disasters. DSRs are able to control power flows through meshed transmission grids and thus improve the power transfer capability. This can improve the penetration level of renewable generation as well which is addressed in this paper. The problem of integrating DSRs into transmission grids is formulated as a mixed integer linear programming problem. Different load and wind profiles and a predefined number of disaster scenarios are considered in evaluating the impacts of DSR deployment on system's operational costs, wind curtailment and load shedding during disasters and normal condition. The uncertainty of wind generation can affect economic viability of DSRs deployment thus; an information gap decision theory based method is proposed for uncertainty handling. The proposed methodology is implemented on the IEEE-RTS 24 bus test system and results show the functionality of DSRs in converting the conventional transmission grid into a flexible and dispatchable asset.

Index Terms

Power system resiliency, distributed series reactors, wind curtailment, information gap decision theory, uncertainty.

NOMENCLATURE

For quick reference, the main notation used throughout the paper is stated in this section.

A. Sets and Indices

i Index for network buses.

Alireza Soroudi and Andrew Keane are with the School of Electrical, Electronic and Communications Engineering, University College Dublin, (e-mail: alireza.soroudi@ucd.ie)

*P. Maghouli is with Department of Electrical Engineering, Shahed University, Tehran, Iran, (e-mail: p.maghouli@shahed.ac.ir)

ℓ	Index for network feeders.
t	Index for operation intervals.
g	Index for thermal generating units.
k	Index for blocks considered for piecewise linear fuel cost function
Ω_B	Set of all network buses
Ω_k	Set of blocks used for linearizing the fuel cost function
Ω_{G_b}	Set of generating units connected to bus b
Ω_S	Set of disaster scenarios
Ω_L	Set of lines in distribution network
Ω_T	Set of time periods

B. Parameters

$\tau_{t/s}$	Duration of time period t or scenario s (hours)
d_t	Demand coefficient indicating the ratio of demand to peak load in time t (normal condition)
n	Equipment life time (years)
a_g, b_g, c_g	Fuel cost coefficients for unit g
\bar{P}_{bi}^ℓ	Flow limit of line ℓ in normal condition (MW)
$\bar{P}_{bi,s}^\ell$	Flow limit of line ℓ in scenario s (MW)
λ_{DSR}	Investment cost for DSR (\$)
r	Interest rate
B_{bi}^0	Initial susceptance of line ℓ (Ohm)
$P_{g,ini/fin}^k$	Initial and final values of power in block k of linearized cost of thermal unit g (MW).
$C_{g,ini/fin}^k$	Initial and final values of cost in block k of linearized cost of thermal unit g (\$/h).
ΔP_g^k	Length of block k of linearized cost of thermal unit g (MW).
λ_D	Load shedding cost (\$/MWh)
Δ_{bi}^{min}	Min possible deviation from initial susceptance of line ℓ
N_{DSR}^{max}	Maximum number of lines allowed to have DSR
$P_g^{min/max}$	Min/max operating range of thermal unit g (MW)
$P_{g,s}^{min/max}$	Min/max operating condition of generating unit g in scenario s (MW)
$\delta_b^{min/max}$	Min/max operating condition of voltage angle in bus b (Rad)
$P_{b,t/s}^L$	Power demand at bus b and time t (MW)
η_n	Probability of normal condition
\bar{P}_b^L	Peak Peak load in bus b (MW)
$\beta_{c/o}$	Percentage of critical/opportunistic increase/decrease in objective function

π_s	Probability of scenario s
s_g^k	Slope of cost in block k of linearized cost of thermal unit g (\$/MW).
λ_W	Wind curtailment cost (\$/MWh)
w_t	Wind coefficient indicating the availability of wind resource in time t (normal condition)
γ_s	Wind coefficient indicating the availability of wind resource in scenario s (contingency condition)
Λ_b^W	Wind capacity at bus b (MW)

C. Variables

I_{bi}	Binary variable indicating if DSR exists (1) in line ℓ or not (0)
$C_{f/lsh/wc}$	Fuel, load shedding and wind curtailment costs (\$)
$C_{g,t}$	Fuel cost of thermal unit g at time t (\$)
$P_{g,t/s}^G$	Generated power of thermal unit g at time t or scenario s (MW)
$P_{b,t/s}^{SH}$	Load shedding at bus b and time t / scenario s (MW)
$OF_{n/d}$	Objective function in normal/disaster condition
$p_{g,t}^k$	Operating schedule of thermal unit g in block k at time t (MW).
$P_{bi,t/s}^\ell$	Power flow in line ℓ at time t or scenario s (MW)
$B_{bi,t/s}$	Susceptance of line ℓ at time t or scenario s
$\mu_{b,t}$	Shadow price at bus b and time period t (\$/MWh)
$\delta_{b,t/s}$	Voltage angle of bus b at time t or scenario s
$P_{b,t/s}^C$	Wind power curtailment at bus b and time t /scenario s (MW)
$P_{b,t/s}^W$	Wind power generation at bus b and time t /scenario s (MW)

I. INTRODUCTION

The two main challenges for developing more sustainable energy systems are the resiliency improvement against high impact events and variable renewable resources. A class of risks, called High-Impact, Low-Frequency (HILF) events, has recently become a renewed focus of risk managers and policy makers [1]. These events include a variety range from deliberate attacks to weather related risks while severe weather conditions caused approximately 80% of the large-scale outages in recent years [2]. Besides, any transmission constraints or bottlenecks in transmission system could prevent perfect utilization of renewable resources [3]. Thus enhancing the transmission grid resilience to HILF events and renewable resources is becoming of increasing interest. In fact, the most obvious measure for improving transmission system resilience is to improve its transfer capacity by building new transmission lines. However due to necessity of public acceptance, huge investment costs and long lead construction time, other measures attained more attention

in recent years.

Improving the observability and operational flexibility of the grid could be considered as a smart measure for improving the transmission grid resiliency [4]. Different measures are proposed for improving the transmission capacity of existing infrastructure by deploying FACTS or Distributed FACTS devices or line switching [5]. All these measures are studied for proposing a smarter and dispatchable transmission grid, extracting more value from existing network, manage congestion and improve transfer capability of the network by controlling the power flow pattern in the grid. While high capital costs and low reliability restricted the widespread use of FACTS devices, Distributed Series Reactors (DSR) could be considered as a low cost, reliable and smart devices for power flow control in transmission grids [6]. They have short lead times and do not require substation modifications or special insulation design. DSRs can shift the power from overloaded or congested lines to underutilized transmission lines, enhancing system overall loadability. They can also monitor line temperature and work as a sensor for dynamic rating of overhead lines. Previous research has shown the ability of similar devices in improving the system loadability and reducing load shedding due to transmission outages [6]. However, decision makers need a comprehensive cost-benefit analysis framework for deployment of DSRs. Evolutionary algorithms have been proposed for the problem of optimal locating of FACTS devices [7], with some specific advantages and disadvantages. Sensitivity methods were also applied for determining the most influential locations of series FACTS devices [8].

Previous research on transmission grid resiliency improvement were mainly focused on system hardening [9] while in [10] e.g. line switching is proposed as a flexible measure for improving the transmission resiliency against deliberate outages.

The main focus of this paper is to propose a planning algorithm for optimal allocation of DSRs for improving system resilience to HILFs (or disasters) and renewable resources variability. Variability and uncertainty of renewable resources [11] should be addressed in economic viability of DSRs deployment, thus the Information Gap Decision Theory (IGDT) method [12] is applied for estimating a robust level of benefits of DSR deployment. The IGDT method can assess performance of different planning alternatives under both dire and opportune future conditions. Under the robust approach, this technique seeks to maximize robustness of the final decision given minimum performance requirement. Besides above ability to explore risks and opportunities simultaneously, this method requires very low computational burden which is crucial in planning studies for composing a tractable formulation. It is a computationally powerful tool for dealing with uncertainties especially when robust decision making is preferred. In this regard, the main goal is to maximize optimal solution immunity to the effects of deviation of wind generation from what is estimated (as main source of uncertainty); or to maximizing info-gap robustness. Disasters are incorporated in the model through a set of predefined outage scenarios. It is shown that the optimal deployment of DSRs can increase renewable generation penetration and improve system functionality under severe disasters. The fundamental

contributions of the paper are threefold as follows:

- To provide a framework for optimal allocation of DSR units to increase the resiliency of transmission network.
- To develop a risk-averse strategy which considers the uncertainties of wind turbine power generation and contingencies.
- Computationally efficient uncertainty modeling is developed which is suitable for severe uncertainty cases.

II. PROBLEM DEFINITION

A. Resiliency measures

Different definitions have been proposed for resiliency in the literature. Generally, it can be defined as an index measuring the capacity to sustain a level of functionality or performance for a given infrastructure over a given period of time [13]. Different performance measures are also proposed in the context of infrastructure resilience such as: connectivity loss, power loss, and impact on the population [14]. However, in the context of power systems, Ref. [15] presents a comprehensive definition: resilience is defined as the ability of a power system to withstand extraordinary and high impact-low probability events such as extreme weather, rapidly recover from such disruptive events and learn lessons for adapting its operation and structure to prevent or mitigate the impact of similar events in the future. Thus resiliency has a multi-dimensional aspect and differs substantially from classical reliability concepts.

It should be noted here that it is even impossible for addressing all resiliency aspects in power system planning studies and here we consider the main impact of disasters on power system functionality as its main function is to deliver electrical energy to end users. Any disaster can be assessed by its impact on power outages and the duration of these outages. In fact, by calculating the amount of load shedding originated by outages in the grid and its duration, different performance measures could be addressed. Thus in this study, the overall load shedding and the duration due to network outages are considered as the resiliency metric. It is considered that network outage scenarios are known in advance and the durations are also predictable. Outage scenarios could be identified based on operator experience, climate analysis and previous behavior of the network under extreme events or even by optimization techniques specially developed in the context of deliberate outage studies [10]. Furthermore outage duration is a function of network operational flexibility, adaptability and operator situational awareness and restoration procedures and also the disaster nature and behavior which is out of the scope of this paper.

The resiliency of power system to renewable generation integration is also studied under normal and contingency operation of the power grid. By increasing the share of uncontrolled and variable renewable

generation in power grids, the resiliency of power systems against renewable generation have attracted more attentions for maximizing variable renewable penetration [16].

B. Distributed Series Reactors (DSRs)

Grid resiliency could be improved through redundancy or through flexibility. DSRs can provide flexibility to the grid by turning the classical transmission grid to a dispatch-able one which could be controlled by the operator just like conventional power plants. DSRs are clamped to phase conductors and powered by induction from line current. A magnetic link allows the device to inject inductive reactance to increase line impedance [6]. Also, embedded sensors could be equipped with communication medium for dynamic rating of transmission lines. In contrast to inverter based D-FACTS technology, DSRs proposed a reliable solution for power flow control in meshed grids. These devices could be added incrementally to transmission lines as it is needed which provide more flexibility for their investment decisions. By increasing the line impedance of a particular transmission line which is vulnerable to overload, the power flow will be shifted to other parallel paths in the grid. Thus DSRs could be used for increasing system loadability, altering the power flow pattern in the grid and more utilizing the existing infrastructure. In fact, DSRs could be used for achieving controlled degradation of the grid during and after extreme events [17]. In contrast to system hardening measures such as system reinforcing by building new transmission lines, DSRs could present a more economic, faster and smarter solution for improving system resiliency. Any outages in transmission grid will redistribute power flows and may trigger post disturbance overloads in some corridors which consequently may cause additional cascading outages. However, successful implementation of DSRs can manage these outages by coordinated control with other system wide measures such as generation redispatch [4]. In a conventional non-dispatchable grid, the first line which reaches its capacity limit will dictate the system transfer capability. By re-routing the flow from overloaded or congested lines to more lightly loaded lines, DSRs can be used for managing system constraints and minimizing load shedding under line outages [6].

C. Optimization model and uncertainty handling

Indeed any decision making in power system planning should address various uncertainties or at least major ones in input parameters to the decision making process. These uncertainties may adversely influence the objective and/or constraints and consequently the final optimal solution. With increasing the wind penetration level in power systems, all operational and planning decision makings will encounter a severe uncertainty due to intermittent and variable nature of wind generation. In this study, based on IGDT concept, a robust estimation of DSRs implementation benefits will be calculated with regard to wind generation uncertainty as the main source of uncertainty. Like other transmission planning studies, the problem of DSR implementation should be addressed in two phases. In the first phase, decision on DSRs deployment will be made based

on an overall optimization process considering simplified DC lossless model of the transmission grid while ac feasibility, transient stability and other criteria should be checked in the second phase. The benefits of DSRs deployment is estimated by hourly optimizing grid operation under normal and outage conditions. The operator has different measures for grid management i.e. generation dispatch, wind curtailment, DSR dispatch and load shedding. All these measures are incorporated for minimizing the sum of system investment and operational costs and maximizing robustness against wind uncertainty under normal and disaster conditions which will be detailed in the next section.

III. PROBLEM FORMULATION

This section of the paper provides the proposed formulation with the underlying assumptions.

A. Power system operation in normal condition

Objective function of the proposed algorithm includes operational costs in normal operation, load shedding costs in normal and contingency condition, wind curtailment cost in normal operation and annualized investment costs of DSRs. The costs in normal condition (OF_n) which are defined as the total operating costs should be minimized:

$$OF_n = C_f + C_{lsh} + C_{wc} \quad (1)$$

The different costs in (1) are defined as follows:

$$C_f = \sum_{g,t} \tau_t C_{g,t} \quad (2)$$

$$C_{lsh} = \sum_{b,t} \tau_t \lambda_D P_{b,t}^{SH} \quad (3)$$

$$C_{wc} = \sum_{b,t} \tau_t \lambda_W P_{b,t}^C \quad (4)$$

where $C_{g,t}$ is the fuel cost function (in \$/h), which is modeled by a quadratic function as follows.

$$C_{g,t} = a_g P_{g,t}^{G^2} + b_g P_{g,t}^G + c_g \quad (5)$$

The fuel cost function described in (5) has a quadratic form and can be linearized in order to improve the computational performance of the proposed model. The procedure for obtaining the piece-wise linear fuel cost function is depicted in Fig. 1. In this way, non-linear fuel cost function in (5) will be replaced by set of

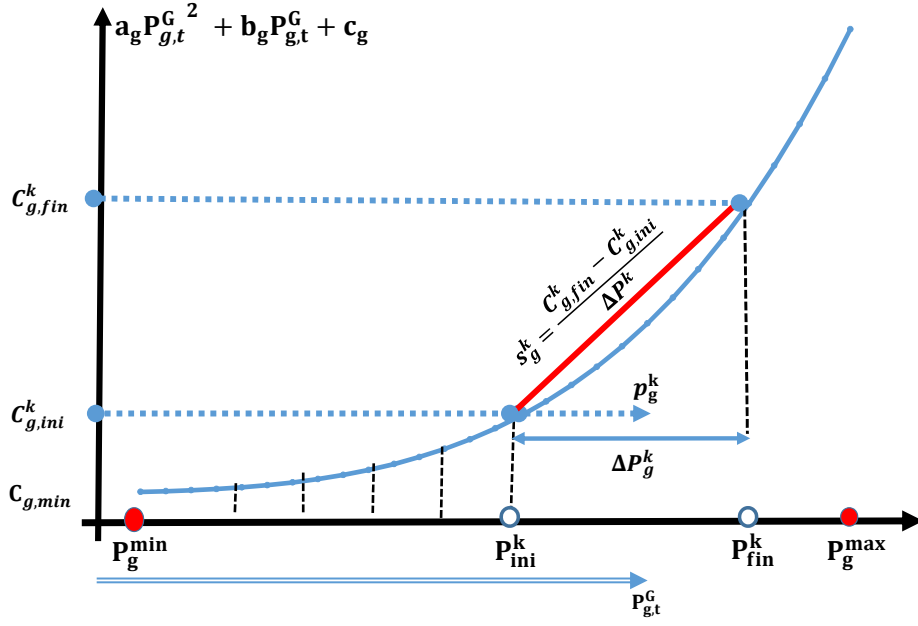

Fig. 1. Piece-wise linear fuel cost function

equations described in (6):

$$C_f = \sum_{g,t} C_{g,t} \quad (6a)$$

$$C_{g,t} = a_g (P_g^{min})^2 + b_g P_g^{min} + c_g + \sum_k s_g^k P_{g,t}^k \quad (6b)$$

$$s_g^k = \frac{C_{g,fin}^k - C_{g,ini}^k}{\Delta P_g^k} \quad (6c)$$

$$C_{g,ini}^k = a_g (P_{g,ini}^k)^2 + b_g P_{g,ini}^k + c_g \quad (6d)$$

$$C_{g,fin}^k = a_g (P_{g,fin}^k)^2 + b_g P_{g,fin}^k + c_g \quad (6e)$$

$$0 \leq p_{g,t}^k \leq \Delta P_g^k, \forall k \in \Omega_k \quad (6f)$$

$$\Delta P_g^k = \frac{P_g^{max} - P_g^{min}}{|\Omega_k|} \quad (6g)$$

$$P_{g,ini}^k = (k - 1)\Delta P_g^k + P_g^{min} \quad (6h)$$

$$P_{g,fin}^k = \Delta P_g^k + P_{g,ini}^k \quad (6i)$$

$$P_{g,t}^G = P_g^{min} + \sum_k P_{g,t}^k \quad (6j)$$

The DC power flow equations and constraints of the system are as follows ($\forall t \in \Omega_T, \forall b, i \in \Omega_B$) :

$$\sum_{g=1}^{\Omega_{G_b}} P_{g,t}^G + P_{b,t}^W - P_{b,t}^L + P_{b,t}^{SH} = \sum_{i=1}^{\Omega_B} P_{bi,t}^\ell : \mu_{b,t} \quad (7)$$

$$P_{bi,t}^\ell = B_{bi,t}(\delta_{b,t} - \delta_{i,t}) \quad (8)$$

The $B_{bi,t}$ in (8) is the dynamic susceptance of line connecting bus b to bus i . It is dynamic only if it is equipped with DSR. The DSR setting ($\zeta_{bi,t}$) is formulated in (9).

$$B_{bi,t} = B_{bi}^0 \zeta_{bi,t} \quad (9a)$$

$$1 - \Delta_{bi}^{min} \leq \zeta_{bi,t} \leq 1 \quad (9b)$$

However, if (8) is substituted by (9) it will cause non-linearity of the formulation. A linear formulation [18] is used which can be used for modeling the DSR as follows:

$$B_{bi}^0 - \Delta_{bi}^{min} \times I_{bi} \leq B_{bi,t} \leq B_{bi}^0 \quad (10)$$

where the following limits are considered $\forall t \in \Omega_T$.

$$P_g^{min} \leq P_{g,t}^G \leq P_g^{max} \quad \forall g \in \Omega_G \quad (11)$$

$$\delta_b^{min} \leq \delta_{b,t} \leq \delta_b^{max} \quad \forall b \in \Omega_B \quad (12)$$

$$-\bar{P}_{bi}^\ell \leq P_{bi,t}^\ell \leq \bar{P}_{bi}^\ell \quad \forall \ell \in \Omega_L \quad (13)$$

$$0 \leq P_{b,t}^W \leq w_t \Lambda_b^W \quad \forall b \in \Omega_B \quad (14)$$

$$P_{b,t}^L = d_t \bar{P}_b^L \quad \forall b \in \Omega_B \quad (15)$$

$$0 \leq P_{b,t}^C \leq w_t \Lambda_b^W - P_{b,t}^W \quad \forall b \in \Omega_B \quad (16)$$

The maximum number of lines than can be equipped with DSR is specified as follows:

$$\sum_{b,i} I_{bi} \leq N_{DSR}^{max} \quad (17)$$

B. Power system operation under contingency condition

Disasters are defined by a set of predefined outages or contingencies and system resiliency is measured by calculating amount of load shedding in each outage scenario. Spatial and temporal dynamics of disasters can be captured though these predefined outage scenarios with different time schedules. Objective function in contingency condition (OF_d) is defined as the total load shedding costs which is needed to be minimized:

$$OF_d = C_{lsh}^d \quad (18)$$

The overall cost of load shedding in case of disasters is calculated as follows:

$$C_{lsh}^d = \sum_{b,s} \pi_s \tau_s \lambda_D P_{b,s}^{SH} \quad (19)$$

The DC power flow equations of the system are as follows ($\forall s \in \Omega_S, \forall b \in \Omega_B$) :

$$\sum_{g=1}^{\Omega_{G_b}} P_{g,s}^G + P_{b,s}^W - P_{b,s}^L + P_{b,s}^{SH} = \sum_{i=1}^{\Omega_B} P_{bi,s}^\ell \quad (20)$$

$$P_{bi,s}^\ell = B_{bi,s}(\delta_{b,s} - \delta_{i,s}) \quad (21)$$

$$B_{bi}^0 - \Delta_{bi}^{min} \times I_{bi} \leq B_{bi,s} \leq B_{bi}^0 \quad (22)$$

where the following limits are considered, $\forall s \in \Omega_S$:

$$P_{g,s}^{min} \leq P_{g,s}^G \leq P_{g,s}^{max} \quad \forall g \in \Omega_G, \quad (23)$$

$$\delta_b^{min} \leq \delta_{b,s} \leq \delta_b^{max} \quad \forall b \in \Omega_B \quad (24)$$

$$-\bar{P}_{bi,s}^\ell \leq P_{bi,s}^\ell \leq \bar{P}_{bi,s}^\ell \quad \forall \ell \in \Omega_L \quad (25)$$

$$0 \leq P_{b,s}^W \leq \gamma_s \Lambda_b^W \quad \forall b \in \Omega_B \quad (26)$$

$$0 \leq P_{b,s}^{SH} \leq P_{b,s}^L \quad \forall b \in \Omega_B \quad (27)$$

The operating limits indicated in (23) and (25) may be different with those provided in (11) and (13). The disaster may reduce the thermal rating of transmission lines [19] or cause the total outage of the component.

The combination of (21) and (22) implies that:

$$P_{bi,s}^\ell \geq (B_{bi}^0 - \Delta_{bi}^{min} \times I_{bi})(\delta_{b,s} - \delta_{i,s}) \quad (28a)$$

$$P_{bi,s}^\ell \leq B_{bi}^0(\delta_{b,s} - \delta_{i,s}) \quad (28b)$$

In (28a), the multiplication of I_{bi} and $(\delta_{b,s} - \delta_{i,s})$ makes the formulation non-linear. The linearisation procedure is explained in Appendix A.

C. Overall objective function

The overall objective function to be minimized includes system operational costs in normal operation, load shedding costs during outages and annualized investment costs of DSRs which is defined as follows :

$$OF = \eta_n OF_n + (1 - \eta_n) OF_d + C_{inv} \quad (29)$$

where,

$$C_{inv} = \frac{r(1+r)^n}{(1+r)^n + 1} \sum_{b,i} \lambda_{DSR} I_{bi} \quad (30)$$

In (30), n is the equipment life time. All operational costs in above objective are subjected to wind generation uncertainty which is handled by the IGDT method.

IV. UNCERTAINTY MODELING VIA IGDT

The decision making is defined as the procedure for finding the optimal set of actions (decision variables) in order to minimize or maximize a given set of objectives. Every decision making tool requires some input parameters. For example in DSR allocation problem, the technical characteristic of thermal/wind power generating units as well as the connection points to the grid and network topology constitute the input parameters. Some input parameters such as wind generation pattern (which depends on natural resources) are subject to uncertainty. The uncertainty of input parameter makes the decision making procedure a more difficult task for the decision maker. The wind generation uncertainty can highly influence the decision variables as well as the objective function. There are some techniques to model these uncertainties such as stochastic modeling [20], fuzzy modeling [21] and robust optimization (RO) [22]. Selecting the appropriate tool for modeling the uncertainty highly depends on the level of available information about the uncertain parameters. Stochastic methods need probability density function (PDF), fuzzy models need membership function and robust optimization requires the detailed and precise uncertainty sets. The stochastic models are usually solved using Monte Carlo simulations [23] or Scenario based approach [24]. The Monte Carlo requires multiple number of iterations in order to provide some level of confidence for decision maker. On the other hand, the scenarios in scenario based approach should be carefully defined. This is because of the fact that the obtained results are highly dependent and sensitive to these scenarios and can't provide a guaranteed cost/benefit for the decision maker. The fuzzy modeling approach, requires running multiple simulations for different levels of membership degrees [25] (two simulations for every objective function in each membership degree). The robust optimization is usually a multi-level optimization problem (the same as IGDT) but needs more info regarding the uncertainty set. This technique is not applicable in severe uncertainty cases. Almost all of these techniques are computationally expensive. This would justify the need for a powerful tool that would be able to overcome these shortcomings.

The idea of Information Gap Decision Theory (IGDT) was first introduced in [26]. The aim is finding the optimal set of decision variables in a way that increases the robustness against uncertainties or maximizing

the chance of success. The DSR allocation problem can be expressed as a minimization problem as in (31):

$$\begin{aligned} & \min_{\xi} OF & (31) \\ & \text{Subject to} \\ & (1) \text{ to } (30) \end{aligned}$$

The objective function in (31) is the total cost defined in (29) which should be minimized. The decision variables (ξ) and the input uncertain parameter ($P_{b,t}^W$) should satisfy the specified constraints (1) to (30). The decision variables include the thermal generation schedules, wind power curtailment, DSR location and settings in normal/contingency conditions as follows:

$$\xi = \{P_{g,t/s}^G, P_{b,t/s}^C, P_{b,t/s}^{SH}, I_{bi}, B_{bi,t/s}\} \quad (32)$$

In IGDT literature, the most common way of describing the uncertainties in IGDT framework is uniform bound model as given in (33):

$$U(\alpha, \bar{P}_{b,t}^W) = \{P_{b,t}^W : |P_{b,t}^W - \bar{P}_{b,t}^W| \leq \alpha \bar{P}_{b,t}^W\} \quad (33)$$

The forecasted value of wind power generation ($\bar{P}_{b,t}^W$) is assumed to be known. This is the only information available regarding the uncertain parameter ($P_{b,t}^W$). The variable (α) is “radius of uncertainty” which is also unknown. It shows the distance between the predicted value ($\bar{P}_{b,t}^W$) and what may actually happen in reality ($P_{b,t}^W$). The IGDT modeling has two forms as follows:

- Risk Averse (RA) [27]
- Opportunity Seeker (OS) [28]

In both strategies, the base case cost (f_b) is calculated which is the value of OF when there is no difference between the prediction and actual value of wind availability. The formulated problem is solved assuming that $P_{b,t}^W = \bar{P}_{b,t}^W$.

$$f_b = \min_{\xi} OF \quad (34)$$

Subject to

$$\alpha = 0 \quad (35)$$

(1) to (30)

A. Risk Averse (RA) strategy

The Risk Averse (RA) strategy tries to find the optimal decision variables to maximize the tolerance against the uncertainty. This maximization is performed while constraining the objective function to a predefined level of acceptable deterioration. This strategy answers the question: “what is the maximum information gap ($\hat{\alpha}$) that the objective function can tolerate?”. i.e., remains below a critical level Δ_c .

$$\hat{\alpha}(\xi, \bar{P}_{b,t}^W) = \max_{\alpha} \alpha \quad (36a)$$

$$\max_{P_{b,t}^W} OF \leq \Delta_c \quad (36b)$$

$$P_{b,t}^W \in U(\alpha, \bar{P}_{b,t}^W) \quad (36c)$$

(1)to(30)

It should be noted that the optimization in (36a) is performed for a given value of (ξ) and decision variable is α . In the lower level (36a), the optimization is done assuming the values of α, ξ are known.

The critical level Δ_c in (36b) is usually specified by the planner as a percentage of increase (β_c) in base case cost (f_b) like : $\Delta_c = (1 + \beta_c)f_b$.

The final step is to maximize the $\hat{\alpha}(\xi, \bar{P}_{b,t}^W)$ using the decision variables (ξ).

$$R_c = \max_{\xi} \hat{\alpha} \quad (37a)$$

$$\hat{\alpha}(\xi, \bar{P}_{b,t}^W) = \max_{\alpha} \alpha \quad (37b)$$

$$\max_{P_{b,t}^W} OF \leq \Delta_c \quad (37c)$$

$$P_{b,t}^W \in U(\alpha, \bar{P}_{b,t}^W) \quad (37d)$$

(1)to(30)

The problem described in (37) is a tri-level optimization problem. At the lowest level, $P_{b,t}^W \in U(\alpha, \bar{P}_{b,t}^W)$. This means that $(1 - \alpha)\bar{P}_{b,t}^W \leq P_{b,t}^W \leq (1 + \alpha)\bar{P}_{b,t}^W$. The solution for (37c) and (37d) is $(1 - \alpha)\bar{P}_{b,t}^W = P_{b,t}^W$ since the reduction in wind power would increase the fuel cost of thermal units. The solution for the second

level (37b) is trivial $\alpha = \frac{\bar{P}_{b,t}^W - P_{b,t}^W}{\bar{P}_{b,t}^W}$. The tri-level optimization (37c) would become single level as follows:

$$R_c = \max_{\xi} \alpha \quad (38a)$$

$$P_{b,t}^W = (1 - \alpha) \bar{P}_{b,t}^W \quad (38b)$$

$$OF \leq (1 + \beta_c) f_b \quad (38c)$$

(1)to(30)

B. Opportunity Seeker (OS) strategy

Due to the nature of the problem under study (which is risk averse), the opportunity seeker strategy is not applicable. However, it is described here to provide a better understanding. In opportunity seeker (OS) strategy, the decision maker tries to find the best set of decision variables to increase the chance of reduction in objective function (compared to f_b) if the uncertain parameter behaves in favor of cost reduction. The first step (the same as RA) is calculating the base case value (f_b) by solving (34). The second step is finding the minimum radius of **desired** uncertainty ($\tilde{\alpha}$) that the objective function can reach an opportunity level $\Delta_o \leq f_b$.

$$\tilde{\alpha}(\xi, \bar{P}_{b,t}^W) = \min_{\alpha} \alpha \quad (39a)$$

$$\min_{P_{b,t}^W} OF \leq \Delta_o \quad (39b)$$

$$P_{b,t}^W \in U(\alpha, \bar{P}_{b,t}^W) \quad (39c)$$

(1)to(30)

The minimum required uncertainty level is found in (39) as $\tilde{\alpha}(\xi, \bar{P}_{b,t}^W)$. The final step is to minimize the $\tilde{\alpha}(\xi, \bar{P}_{b,t}^W)$ using the decision variables (ξ) as follows:

$$R_o = \min_{\xi} \min_{\alpha} \min_{P_{b,t}^W} \alpha \quad (40a)$$

$$OF \leq \Delta_o = (1 - \beta_o) f_b \quad (40b)$$

$$P_{b,t}^W \in U(\alpha, \bar{P}_{b,t}^W) \quad (40c)$$

(1)to(30)

The opportunity level Δ_o in (40) is usually specified by the planner as a percentage of decrease (β_o) in base case cost (f_b) like : $\Delta_o = (1 - \beta_o) f_b$. More detail can be found in [26].

V. SIMULATION RESULTS

A. Data

The proposed IGDT-based model for integration of DSRs in transmission systems is implemented on the IEEE-RTS 24 bus reliability test system (Fig. 1). The data of this system is adopted from [29] with some modifications. The overall loading of the system is given in Table I. Interest rate (r) is assumed to be 3%. All transmission lines except transformers are considered as the candidate lines for installing DSRs. The mathematical model of proposed framework is implemented in General Algebraic Modeling System (GAMS) [30] environment and solved by CPLEX solver [31] running on an Intel $\text{\textcircled{R}}$ XeonTMCPU E5-1620 3.6 GHz PC with 8 GB RAM. The DSR flexibility is assumed that $\Delta_{bi}^{min} = 0.2B_{bi}^0$.

TABLE I
PEAK DEMAND VALUES IN DIFFERENT BUSES

Bus	Peak Demand (MW)	Bus	Peak Demand (MW)
1	108	10	170
3	100	13	265
4	74	14	100
5	50	15	317
6	136	16	100
7	125	18	333
8	137	19	181
9	155	20	128

A period of one year operation of the system is analyzed for evaluating the objective function proposed in (38). Wind-demand condition and duration are obtained based on the method introduced in [32] for addressing correlations between wind and demand. In this analysis, three different outage scenarios are defined as in Table II which are also depicted in Fig. 2. These outage scenarios could be defined based on historic data or by running optimization procedures for finding most severe outage conditions by methods presented in works on deliberate outages [10]. These scenarios define the duration (τ_s) and severity of the contingency in terms of affected components and the probability of occurrence.

TABLE II
THE CONTINGENCY SCENARIOS

τ_s (h)	Scenarios	Affected components (Case-I)	Scenarios	Affected components (Case-II)
8	S_1	ℓ_{10-12}	S_4	$\ell_{11-13}, \ell_{12-13}$
10	S_2	$\ell_{10-12}, \ell_{9-12}$	S_5	ℓ_{1-5} and $\forall g P_{g,b=1}$
6	S_3	$\ell_{10-12}, \ell_{13-11}$	S_6	$\forall g P_{g,b=2}$

It should be noted that the sum of contingency probabilities (π_s) is 2% and they are all assumed to be equal. This means that the system is $\eta_n = 98\%$ in normal condition and $1 - \eta_n = 2\%$ in disaster (contingency) operation. It is assumed that four wind power generators are connected to the grid on different buses as indicated in Table III.

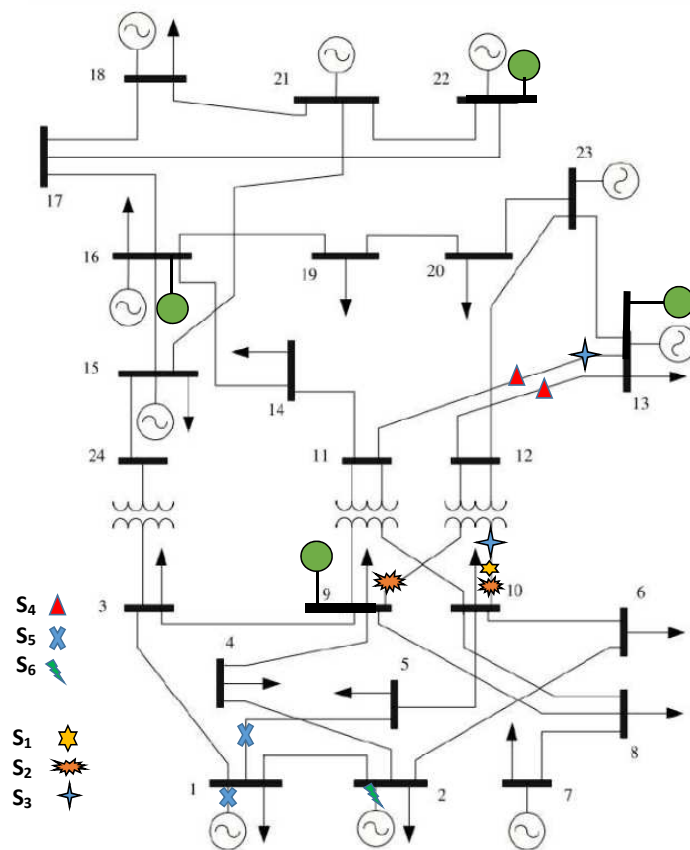

Fig. 2. IEEE reliability 24 bus test system and the considered contingencies

TABLE III
WIND CAPACITIES AND THE CONNECTION POINTS

Number	Λ_b^W (MW)	Connection bus
w1	120	22
w2	120	16
w3	240	13
w4	120	9

The cost of each set of DSRs (three phases) (λ_{DSR}) is assumed to be \$4500. The DSR life time is assumed to be 20 years in this study.

B. Uncertainty analysis

In order to investigate the performance of the proposed framework, the β_c parameter is changed from 0 to 15%. The contingency case I described in Table II, is used to model the contingencies in this section. The risk averse strategies has been implemented in this work. The variations of tolerable uncertainty vs cost target is plotted in Fig. 3. It is observed from Fig. 3 that the tolerable uncertainty increases from 0 ($\beta_c = 0$) to 0.4244 ($\beta_c = 15\%$). This means that the cost target has increased from 168.2220 M\$ (base case) to 193.4553 M\$ ($\beta_c = 15\%$). It is expected to have more tolerance toward the uncertainty when the cost target is increased.

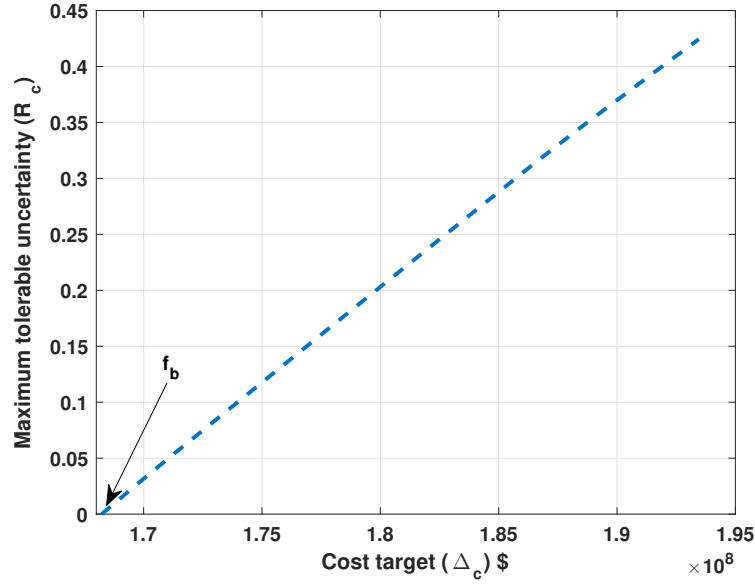

Fig. 3. Tolerable uncertainty vs cost target (RA)

The average computation time of IGDT method is 3.31 seconds as shown for different β_c values in Table IV.

TABLE IV
THE MAXIMUM TOLERANCE LEVEL AGAINST WIND UNCERTAINTY AND COMPUTATION TIME FOR EACH (SECOND) β_c LEVEL

β_c	α	Computation time (seconds)
0.00	0.00001	3.703
0.01	0.02995	4.750
0.02	0.05920	3.094
0.03	0.08803	3.235
0.04	0.11683	3.500
0.05	0.14560	3.187
0.06	0.17435	2.922
0.07	0.20300	3.375
0.08	0.23162	2.750
0.09	0.26016	3.219
0.10	0.28864	3.125
0.11	0.31706	3.344
0.12	0.34463	3.234
0.13	0.37135	3.016
0.14	0.39793	3.265
0.15	0.42441	3.297

Fig. 3 shows the relation between the tolerable uncertainty and cost target.

The optimal allocation of DSRs in the network is shown in Fig. 4 for $\beta_c = 5\%$. Choosing the value of β_c depends on the choice of decision maker. In this work, β_c is assumed to be 5% which covers up to 14.5% of wind power generation uncertainty as depicted in Fig.3. It is observed that 10 lines are chosen to have DSR in this case.

The DSR units will react to the loading condition and availability of wind turbines as well as the other

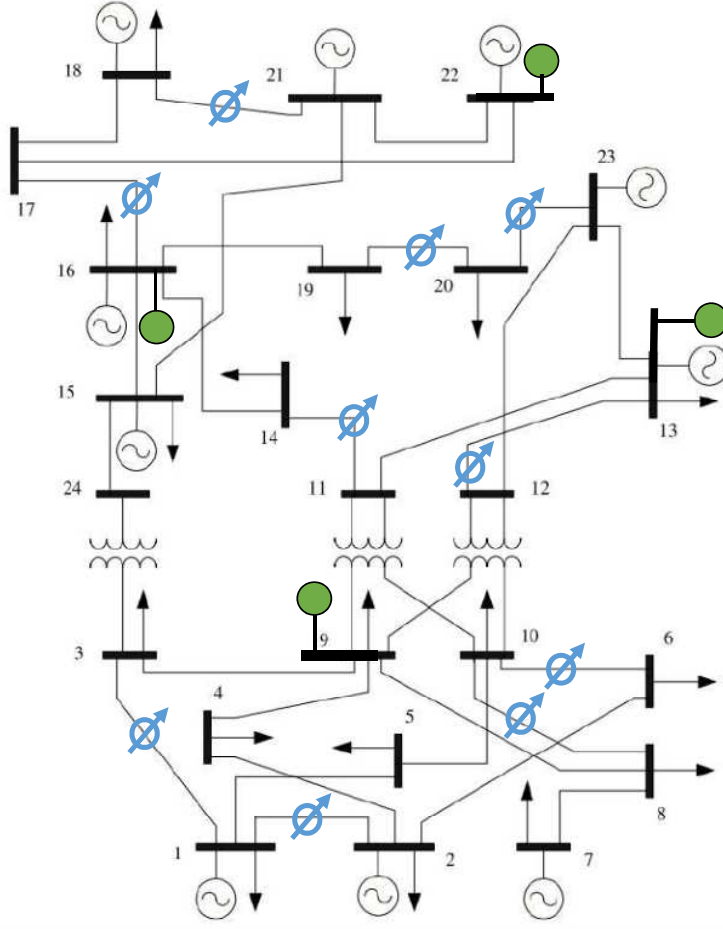

Fig. 4. Optimal allocation of DSR in the network in RA strategy ($\beta_c = 5\%$)

technical characteristics of the network to reduce the overall costs. The optimal DSR settings in different lines and time periods are shown in Fig. 5 for three sample location-periods .

In $\beta_c = 0$ (base case), the share of thermal units and wind units is 84.65 % and 15.34 % in supplying the demand, respectively. In RA strategy, the share of wind decreases to 8.83 % and thermal units to 91.16% ($\beta_c = 15\%$).

C. Sensitivity analysis

In this section, the incremental effect of deploying DSRs in the system is analyzed. The optimal locations of DSRs are obtained by the proposed method sequentially with a constraint on the maximum number of lines that can host DSRs ($N_{DSR}^{max}=0$ to 10). Two case studies have been investigated :

- Case-I (Scenarios $S_{1,2,3}$ in Table II) tries to find out the line only contingencies.
- Case-II (Scenarios $S_{4,5,6}$ in Table II) investigates the simultaneous outages of transmission lines and generating units.

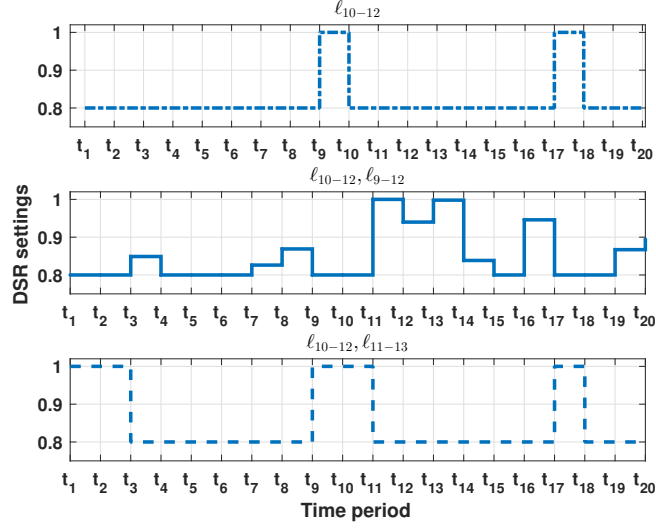

Fig. 5. DSR setting in different lines and time periods (normal condition) ($\beta_c = 5\%$)

1) *Contingency case-I*: The line outage scenarios ($S_{1,2,3}$) are taken from Table II. The optimal DSR connection branches are provided in Fig. 4. The total load shedding costs (\$) in case of disaster (i.e. outage scenarios) vs number of lines equipped with DSR are shown in Fig. 6. The total costs and operating costs (\$) vs the number of lines equipped with DSR are shown in Fig. 7. The total costs in Fig. 7 are calculated in (29). As it can be seen in Fig. 6, the load shedding cost is monotonically decreasing by increasing the lines equipped by DSRs but with different rates showing the capability of a flexible transmission network to manage disaster consequences. Please note that the amount of load shedding presents the most important measures of resiliency i.e. connectivity loss, power loss and impact on end users. The graph shown in Fig.

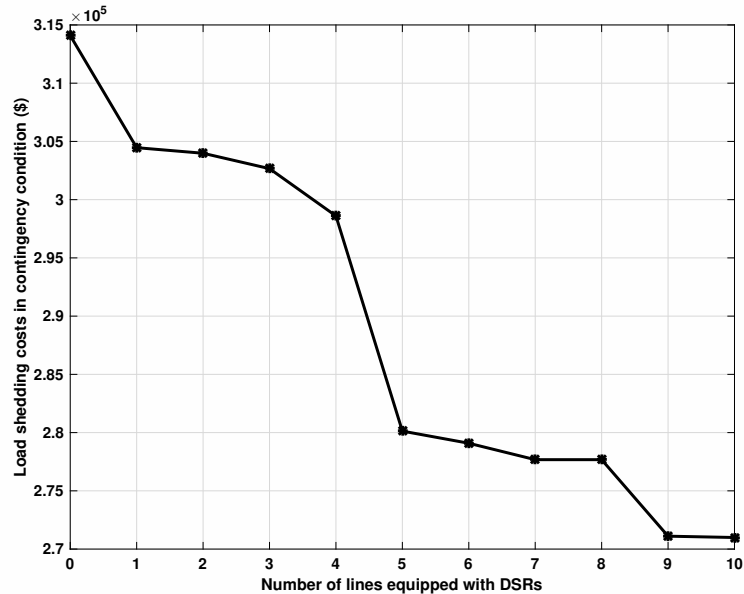

Fig. 6. Total load shedding costs (OF_d) in case of disaster vs number of lines equipped with DSR (Case-I)

6, shows the impact of no DSR (zero lines equipped with DSR) and 10 DSR units installed on the system. \$314090.61 (no DSR)- \$270993.64 (10 DSRs)=\$43096.97. In other words, 13% reductions in total load shedding costs can be achieved by equipping 10 branches with DSRs. The DSR settings in contingency case-I are given in Table V.

TABLE V
DSR SETTINGS ($\frac{B_{bi,t}}{B_{bi}^0}$) IN CONTINGENCY CASE-I

DSR location	S_1	S_2	S_3
l_{2-1}	1	1	0.8
l_{3-1}	0.8	0.8	0.8
l_{10-6}	0.8	0.8	0.8
l_{10-8}	1	1	1
l_{13-12}	0.8	1	1
l_{14-11}	0.8	0.8	0.8
l_{17-16}	0.8	0.8	0.8
l_{20-19}	0.8	1	0.8
l_{21-18}	0.8	0.8	0.8
l_{23-20}	0.8	1	0.8

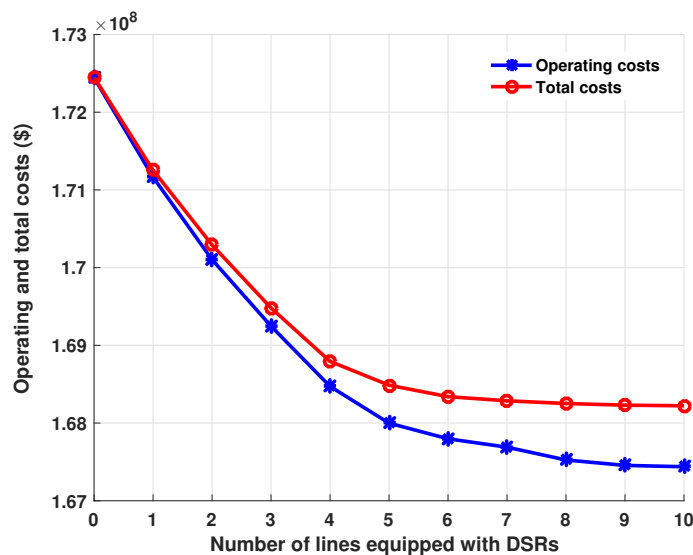

Fig. 7. Total cost and operating costs (\$) vs number of lines equipped with DSR

DSRs can shift the power flow from over-loaded lines to the lightly loaded ones and improve transmission system overall performance. This capability can influence the operational flexibility of the system in hosting wind generation. The total wind curtailment cost (\$) vs number of lines equipped with DSR for different percentages of increase in wind capacity is depicted in Fig. 8. It is clear that the DSRs are more beneficial with higher wind penetrations. These sensitivity studies depicted in Figs. 6 to 8 show the acceptable performance of DSRs for improving system operational efficiency and resiliency.

2) *Contingency case-II*: The line-generation outage scenarios ($S_{4,5,6}$) are taken from Table II. The optimal DSR allocation is provided in Fig. 4 which is the same as the contingency case-I. The total load shedding

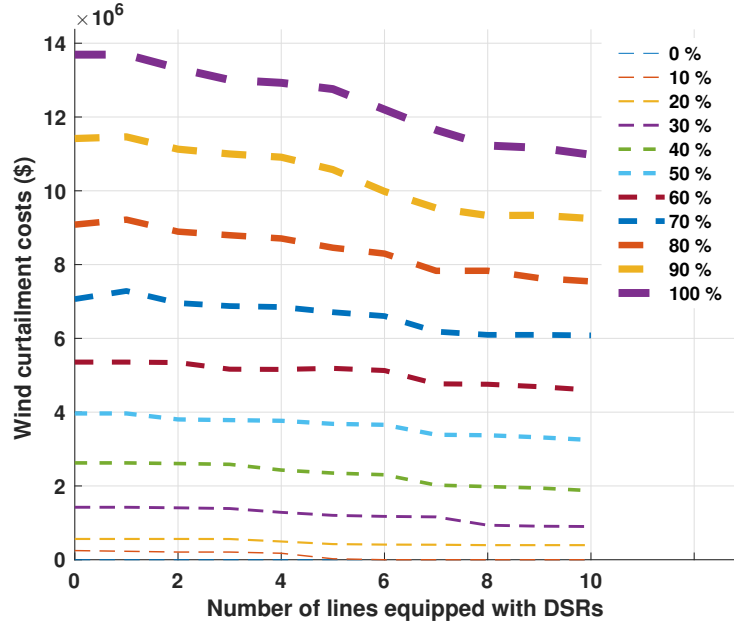

Fig. 8. Total wind curtailment cost (\$) vs number of lines equipped with DSR for different percentages of increase in wind capacity

costs (\$) in case of disaster (i.e. outage scenarios) vs number of lines equipped with DSR are shown in Fig. 9. The graph shown in Fig. 9, indicates that the use of DSR (in 10 lines) can reduce the total load shedding

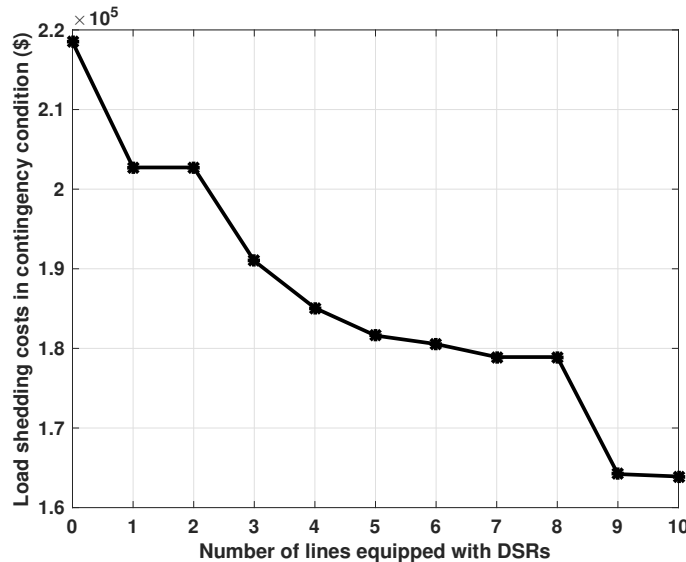

Fig. 9. Total load shedding costs (OF_d) in case of disaster vs number of lines equipped with DSR (Case-II)

costs by \$54565.12 in contingency case-II. This is approximately equal to 25% reduction of load shedding costs compared to no DSR units case. The DSR locations in case-II is the same as those in case-I. However, in contingency condition the operating setting would be different since the network topology changes. The DSR settings in contingency case-II are given in Table VI. Comparing Table VI and Table V reveals the fact that the DSR setting can adaptively change in case of different contingencies to reduce the total load

shedding costs. In scenario S_4 of Table VI, the branch ℓ_{13-12} is out of service, thus its corresponding DSR

TABLE VI
THE DSR SETTINGS ($\frac{B_{bi,t}}{B_{bi}^0}$) IN CONTINGENCY CASE-II

DSR location	S_4	S_5	S_6
ℓ_{2-1}	0.8	0.9913	0.8
ℓ_{3-1}	0.8	1	1
ℓ_{10-6}	0.8	0.8	0.8
ℓ_{10-8}	1	1	1
ℓ_{13-12}	[REDACTED]	1	1
ℓ_{14-11}	0.8	1	1
ℓ_{17-16}	0.8	0.8	0.8
ℓ_{20-19}	0.8	0.8	0.8
ℓ_{21-18}	0.8	0.8	0.8
ℓ_{23-20}	0.8	0.8	0.8

setting is not reported. The average computation time of IGDT method for case-II is 3.18 seconds.

VI. CONCLUSION

The proliferation of renewable energy resources and recent natural disasters have amplified the need for an agile power system capable of handling future uncertainties. A key step to develop a sustainable energy system is to improve its resiliency by physical reinforcement or by smarter solutions such as flexibility measures. DSRs are a newly introduced technology for altering static conventional transmission grid to a smarter flexible and dispatchable asset for controlling power flows and to more utilizing existing infrastructure. DSRs are used for improving system operational efficiency and resiliency in presence of wind power generation uncertainty and disaster outages in this paper. The problem of deploying these devices in transmission system is formulated as a MILP optimization problem and wind generation uncertainty is handled by the IGDT method. The main aspects of resiliency i.e. connectivity loss, power loss and impact on the end user is assessed by obtaining load shedding through DC optimal power flow. Also decreasing wind curtailment costs is incorporated in the objective function and results shows the performance of optimally allocated DSRs in controlling load shedding, wind curtailment and operational costs. Increasing transmission lines reactances by DSRs may adversely affect the system voltage and dynamic behavior which is considered for future work by the authors.

APPENDIX A

LINEARIZED PRODUCT OF A BINARY AND A REAL VARIABLE

Suppose it is needed to linearize the product of two variables (one binary and one real variable ($\delta \geq 0$)).

$$Z = I \times \delta \tag{41}$$

I is binary variable and δ is a real one. The following equations are the linear representation of (41):

$$Z \leq \bar{\delta} \times I \quad (42a)$$

$$Z \leq \delta \quad (42b)$$

$$Z \geq \delta - (1 - I)\bar{\delta} \quad (42c)$$

$$Z \geq 0 \quad (42d)$$

where $\bar{\delta}$ is the maximum limit of real variable δ .

ACKNOWLEDGMENT

This publication has emanated from research conducted with the financial support of Science Foundation Ireland (SFI) under Grant Number 16/IFA/4324.

REFERENCES

- [1] NERC, "High-impact, low-frequency event risk to the north american bulk power system," *Jointly-Commissioned Summary Report of the North American Electric Reliability Corporation and the US Department of Energy*, 2009.
- [2] M. Barnacle, S. Galloway, I. Elders, and G. Ault, "Multi-objective transmission reinforcement planning approach for analysing future energy scenarios in the great britain network," *IET Generation, Transmission Distribution*, vol. 9, no. 14, pp. 2060–2068, 2015.
- [3] P. Du, H. Hui, and N. Lu, "Procurement of regulation services for a grid with high-penetration wind generation resources: A case study of ertcot," *IET Generation, Transmission & Distribution*, 2016.
- [4] M. Amin, "Energy infrastructure defense systems," *Proceedings of the IEEE*, vol. 93, no. 5, pp. 861–875, May 2005.
- [5] A. Delgado, J. Arroyo, and N. Alguacil, "Analysis of electric grid interdiction with line switching," *IEEE Transactions on Power Systems*, vol. 25, no. 2, pp. 633–641, May 2010.
- [6] P. Joslin, "Control applications and economic evaluations of distributed series reactors in unbalanced electrical transmission systems," Ph.D. dissertation, Electrical Engineering Department, Virginia Tech, 2015.
- [7] S. Gerbex, R. Cherkaoui, and A. Germond, "Optimal location of multi-type facts devices in a power system by means of genetic algorithms," *IEEE Transactions on Power Systems*, vol. 16, no. 3, pp. 537–544, Aug 2001.
- [8] T. Orfanogianni and R. Bacher, "Steady-state optimization in power systems with series facts devices," *IEEE Transactions on Power Systems*, vol. 18, no. 1, pp. 19–26, Feb 2003.
- [9] N. Romero, N. Xu, L. Nozick, I. Dobson, and D. Jones, "Investment planning for electric power systems under terrorist threat," *IEEE Transactions on Power Systems*, vol. 27, no. 1, pp. 108–116, Feb 2012.
- [10] L. Zhao and B. Zeng, "Vulnerability analysis of power grids with line switching," *IEEE Transactions on Power Systems*, vol. 28, no. 3, pp. 2727–2736, Aug 2013.
- [11] C. Murphy, A. Soroudi, and A. Keane, "Information gap decision theory-based congestion and voltage management in the presence of uncertain wind power," *IEEE Transactions on Sustainable Energy*, vol. 7, no. 2, pp. 841–849, April 2016.
- [12] S. Sarhadi and T. Amraee, "Robust dynamic network expansion planning considering load uncertainty," *International Journal of Electrical Power & Energy Systems*, vol. 71, pp. 140–150, 2015.
- [13] G. P. Cimellaro, O. Villa, and M. Bruneau, "Resilience-based design of natural gas distribution networks," *Journal of Infrastructure Systems*, vol. 21, no. 1, p. 05014005, 2014.
- [14] K. Poljanšek, F. Bono, and E. Gutiérrez, "Seismic risk assessment of interdependent critical infrastructure systems: the case of european gas and electricity networks," *Earthquake Engineering & Structural Dynamics*, vol. 41, no. 1, pp. 61–79, 2012.

- [15] M. Panteli and P. Mancarella, "Influence of extreme weather and climate change on the resilience of power systems: Impacts and possible mitigation strategies," *Electric Power Systems Research*, vol. 127, pp. 259–270, 2015.
- [16] E. Zio and G. Sansavini, "Vulnerability of smart grids with variable generation and consumption: A system of systems perspective," *IEEE Transactions on Systems, Man, and Cybernetics: Systems*, vol. 43, no. 3, pp. 477–487, May 2013.
- [17] M. Panteli and P. Mancarella, "The grid: Stronger, bigger, smarter?: Presenting a conceptual framework of power system resilience," *Power and Energy Magazine, IEEE*, vol. 13, no. 3, pp. 58–66, May 2015.
- [18] M. Sahraei-Ardakani and K. W. Hedman, "A fast Ip approach for enhanced utilization of variable impedance based facts devices," *IEEE Transactions on Power Systems*, vol. 31, no. 3, pp. 2204–2213, May 2016.
- [19] B. Ansari and S. Mohagheghi, "Optimal energy dispatch of the power distribution network during the course of a progressing wildfire," *International Transactions on Electrical Energy Systems*, vol. 25, no. 12, pp. 3422–3438, 2015.
- [20] A. Soroudi and T. Amraee, "Decision making under uncertainty in energy systems: State of the art," *Renewable and Sustainable Energy Reviews*, vol. 28, pp. 376–384, 2013.
- [21] A. Soroudi, "Possibilistic-scenario model for dg impact assessment on distribution networks in an uncertain environment," *IEEE Transactions on Power Systems*, vol. 27, no. 3, pp. 1283–1293, 2012.
- [22] P. Maghouli, A. Soroudi, and A. Keane, "Robust computational framework for mid-term techno-economical assessment of energy storage," *IET Generation, Transmission Distribution*, vol. 10, no. 3, pp. 822–831, 2016.
- [23] C. Li, Z. Dong, G. Chen, F. Luo, and J. Liu, "Flexible transmission expansion planning associated with large-scale wind farms integration considering demand response," *IET Generation, Transmission Distribution*, vol. 9, no. 15, pp. 2276–2283, 2015.
- [24] L. Zhi-gang, Z. Hao, X. Hai-feng, Z. Jiang-feng, L. Xue-ping, and S. Xiao-feng, "Robust ded based on bad scenario set considering wind, ev and battery switching station," *IET Generation, Transmission Distribution*, vol. 11, no. 2, pp. 354–362, 2017.
- [25] A. Soroudi, "Taxonomy of uncertainty modeling techniques in renewable energy system studies," in *Large Scale Renewable Power Generation*. Springer Singapore, 2014, pp. 1–17.
- [26] Y. Ben-Haim, *Info-gap decision theory: decisions under severe uncertainty*. Academic Press, 2006.
- [27] S. Nojavan, H. Ghesmati, and K. Zare, "Robust optimal offering strategy of large consumer using igdt considering demand response programs," *Electric Power Systems Research*, vol. 130, pp. 46–58, 2016.
- [28] M. Alipour, K. Zare, and B. Mohammadi-Ivatloo, "Optimal risk-constrained participation of industrial cogeneration systems in the day-ahead energy markets," *Renewable and Sustainable Energy Reviews*, vol. 60, pp. 421–432, 2016.
- [29] C. G. et al., "The ieee reliability test system-1996. a report prepared by the reliability test system task force of the application of probability methods subcommittee," *IEEE Transactions on Power Systems*, vol. 14, no. 3, pp. 1010–1020, Aug 1999.
- [30] A. Brooke, D. Kendrick, A. Meeraus, R. Raman, and R. Rasenthal, "A users guide, gams software," *GAMS Development corporation*, 1998.
- [31] I. Cplex, "11.0 users manual," *ILOG SA, Gentilly, France*, p. 32, 2007.
- [32] L. Baringo and A. J. Conejo, "Risk-constrained multi-stage wind power investment," *IEEE Transactions on Power Systems*, vol. 28, no. 1, pp. 401–411, Feb 2013.