



<b>Title</b>	Transmission System Impact of Wind Energy Harvesting Networks
<b>Authors(s)</b>	Cuffe, Paul, Smith, Paul, Keane, Andrew
<b>Publication date</b>	2012-10
<b>Publication information</b>	Cuffe, Paul, Paul Smith, and Andrew Keane. "Transmission System Impact of Wind Energy Harvesting Networks." Institute of Electrical and Electronics Engineers, October 2012. <a href="https://doi.org/10.1109/TSTE.2012.2199342">https://doi.org/10.1109/TSTE.2012.2199342</a> .
<b>Publisher</b>	Institute of Electrical and Electronics Engineers
<b>Item record/more information</b>	<a href="http://hdl.handle.net/10197/4730">http://hdl.handle.net/10197/4730</a>
<b>Publisher's statement</b>	© 2012 IEEE.
<b>Publisher's version (DOI)</b>	10.1109/TSTE.2012.2199342

Downloaded 2026-05-02 00:27:53

The UCD community has made this article openly available. Please share how this access benefits you. Your story matters! (@ucd\_oa)



© Some rights reserved. For more information

# Transmission System Impact of Wind Energy Harvesting Networks

Paul Cuffe, *Student Member IEEE*, Paul Smith, Andrew Keane, *Member IEEE*

**Abstract**— The increasing emphasis placed upon renewable sources of energy requires that power systems accommodate a roll out of variable, asynchronous generators throughout transmission and distribution networks. High penetrations levels of such generation will displace synchronous plant and may cause a challenging scarcity of ancillary service providers, notably in the area of reactive power provision. Consequently, the onus must increasingly be laid upon renewable generators to provide the ancillary services necessary to operate the power system. An emerging practice is to connect adjacent distributed generators in a clustered fashion to a dedicated transmission node, an arrangement that offers rich possibilities for participation in transmission-level control. Performance characterisations of such networks will be helpful in planning transmission system development for reduced synchronous plant availability. This work will examine the effect of increasing penetration of wind generators on transmission system voltage levels and voltage security.

**Index Terms**-- distributed generation, voltage control, transmission planning, distribution planning

## I. INTRODUCTION

As penetration levels rise, renewable generators must increasingly be relied upon to provide more than just clean energy to the power system. Amongst systems operators, there are growing concerns [1] that the increasing displacement of conventional generators attending this rise may lead to insecure power systems. While issues such as frequency and dynamic stability may also be problematic, this work will focus on the area of voltage security and reactive power control. As reactive power is not amenable to long-distance transmission, each power system zone must be largely self-sufficient in reactive power reserves. As such, this work is of relevance to those power systems which include renewables-dominated regions. It is anticipated that the problems of reactive power balance under rising renewables penetration will be encountered initially in smaller power systems.

Notably, renewable generators are often connected at distribution voltages, where system operators routinely stipulate inductive operation to counteract voltage-rise. This maximises reactive power absorption at times of peak distributed generation penetration, when synchronous plant is displaced and the transmission system may be ill-equipped to furnish the reactive power demanded. Crucially, modern wind turbines, whether of direct-drive or doubly fed induction generator type, permit control of reactive power operation that

is largely decoupled from active power output e.g [2], and thus may be an apt surrogate for synchronous plant in the ambit of voltage control.

The literature is replete with active control schemes for utilisation of reactive power resources spread throughout a distribution system, such as [3] [4] & [5], though implementation of such schemes has been minimal. Much of the available literature treats the distribution system in isolation, using controllable reactive power sources to optimise local operation, typically in the area of loss minimisation.

The use of transmission-connected wind farms as voltage controllers is an established practice with clear benefits, whose value is reflected in the many grid codes which mandate voltage control abilities for large wind farms [6]. Work such as [7] clearly demonstrates that distributed reactive power resources can also be harnessed to the benefit of the transmission system, although distribution system voltage and current limits can constrain the permissible level of reactive power provision. The emerging weakly-synchronous power system will need to draw on all available sources of reactive power to ensure secure voltage regimes during periods of high renewables penetration.

If such distributed resources are to become operationally important, it is essential that power system planning activities take proper account of the available capability. The extant literature on reactive power planning focuses on the siting, sizing and operation of new dedicated reactive power sources to be added to the transmission system (e.g the corpus of work reviewed in [8])

By contrast, this paper speaks to two broad questions - what level of reactive support is available from distributed resources, and can this capability substitute for the synchronous plant displaced by rising renewable penetrations?

Speaking first to the former question, this work will set out in Section II-A how the Energy Harvesting Network (EHN) concept, here understood as a dedicated section of distribution network used to connect a cluster of adjacent generators (as in [9]), can offer some insight into how disparate distributed resources can be functionally described from the transmission system perspective. An aggregated power plant concept is developed, seeking to give an encapsulated description of an EHN's collective reactive power capability as seen from the connecting transmission node. Complementing this, in Section II-C a transmission planning methodology to assess node-specific voltage control needs under conventional plant displacement is developed. The synthesis of these two planning methodologies will delineate the available reactive resource and will graphically indicate if this resource is sufficient. This should permit anticipation of future voltage control problems. This hypothesis is tested via a full time series load flow analysis in Section VI.

---

This work was conducted in the Electricity Research Centre, University College Dublin, Ireland, which is supported by the Commission for Energy Regulation, Bord Gáis Energy, Bord na Móna Energy, Cylon Controls, EirGrid, Electric Ireland, EPRI, ESB International, ESB Networks, Gaelectric, Intel, SSE Renewables, UTRC and Viridian Power & Energy.

P. Cuffe (paul.cuffe@ucd.ie) is funded through the SFI Research Frontiers Programme under grant number 09/RFP/ECE2394. P. Smith and A. Keane are funded through the Science Foundation Ireland (SFI) Charles Parsons Energy Research Awards.

## II. METHODOLOGY

### A. EHN Characterisation Method

The characterisation process employs two sets of time series simulations, which maximise both injection and absorption of reactive power to the transmission system, thus delineating the available capability envelope [10]. Considering the case where maximum export of reactive power is desired, each constituent Distributed Generator (DG) is set to regulate its terminal voltage to the highest level permitted on the distribution system. As such, each generator will maximise its own reactive power export, unless constrained by a machine or voltage limit.

This simple approach means that the overall reactive output of the cluster can be controlled by periodically issuing new voltage set points to each farm. This work is not concerned with the specifics of how such control may be implemented, but rather with establishing the boundaries of reactive capability given the output profiles of the constituent generators and the prevailing circuit topology used to connect them.

With each generator set to the appropriate mode, a time series load flow simulation is performed over a suitable time period. The active and reactive power flow at the transmission node is recorded at each time step. This large dataset can then be plotted in the (P, Q) plane, to give an indicative facsimile of available reactive power capability.

A more rigorous characterisation of dependable EHN capability can be derived from this dataset, towards achieving an analogue to the capability chart of a synchronous machine ([11] provides some insight here). A statistical characterisation is here proposed to reduce the set, D, of (P, Q) points to a more tractable form.

With the dataset binned on P values, the level of Q that  $n\%$  of operating points within that band exceed is determined. Intuitively, this delineates the range of controllable reactive power available under a given active power output, that may be achieved in  $n\%$  of cases.

This Q threshold value, and the level of the power band, is recorded in the set L, indexed by  $l$  where:

$$\left\{ \begin{array}{l} P_l \\ Q_l \end{array} \right\} \forall l \in L \quad (1)$$

This set L provides the reduced performance characterisation, and is populated by considering the power-band subsets given by binning on P. These subset bins are labelled as B, numbered by b. Membership is given by:

$$B^b = \left\{ \begin{array}{l} P \\ Q \end{array} \middle| bg < P < g(b+1) \right\}, \quad (2)$$

where  $g$  is the arbitrary bin size. From these bins L is populated using the percentile function  $\rho$  to give

$$Ll = \left\{ \begin{array}{l} P_l \\ Q_l \end{array} \middle| Q_l = \rho_n(\{Q \in B^L\}) \right\} \quad (3)$$

The  $(P_l, Q_l)$  description can be smoothed by a regression, to remove noise artefacts stemming from the binning process.

### B. Unit Commitment

As this work is concerned with effects arising from displacement of conventional plant, a realistic unit

commitment and dispatch approach is vital. The unit commitment tool is used in the voltage control adequacy planning methodology, and also provides dispatch schedules for the validating time series simulations.

The tool described in [12] is employed, which formulates the problem as a non-linear mixed integer program that may be solved in a generic solver. The generator model is parametrised by linearised heat rate cost curves, no load costs, start up costs, and generator active power limits. Inter-temporal effects, such as plant minimum up and down times are neglected.

### C. Voltage Control Adequacy Planning Method

In most electricity markets, renewable generators, such as those composing EHNs, are operated as priority dispatch plant. As such, increasing penetration levels of such generators will inevitably displace existing generators, while also establishing altered reactive power requirement [13]. To date, reactive power planning for transmission systems has been focused on identifying appropriate siting and sizing for new VAR sources to be connected to the transmission system. By contrast, the methodology here presented delineates the reactive power requirements of a must-run generator connecting at a given node in the transmission system. The methodology assesses required reactive power support provision, to achieve a given voltage control set-point under a specified droop.

A test generator, of known capacity, is connected to its intended node in the power system, and is operated as a voltage controller. The test generator's output is iteratively increased up to its maximum level. This alters power flows in the system, and existing plant may be displaced as the nett load declines. These factors must be properly understood to assess the test generator's adequacy as a voltage controller.

The unit commitment tool provides a dispatch schedule for the entire system for each incremental test generator output increase up to its maximum rated output. The displacing effect of the test generator's rising output is thus implicitly captured.

At each test generator output level, a load flow calculation is performed, with and without test generator reactive power limits. The former indicates the voltage performance to be anticipated; the latter indicates what level of reactive power capability would be required for fully compliant voltage performance, such that any deficiencies may be identified. This links the (P, Q) capability description of EHN plant with a description of required performance in an equivalent domain. At each test output level, the remaining reactive power reserves in the system are recorded: this gives a global insight into the test generator's effect on system-wide voltage performance.

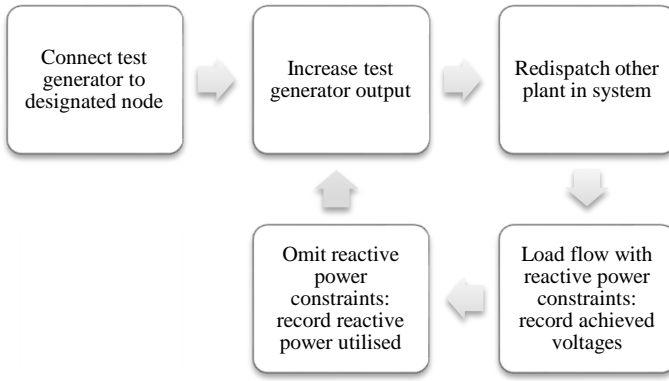

Fig. 1 A process description of voltage control adequacy planning methodology.

#### D. Time Series Simulation

The synthesis of the two preceding methodologies should give prescient insight on an EHN generator's adequacy as a surrogate for conventional plant. The voltage control adequacy planning technique should identify potentially problematic reactive power deficiencies. To validate this, a time series analysis will be performed.

By applying realistic unit commitment and dispatch to serve a varying load, the full effects of conventional plant displacement are captured. Overall transmission system voltage levels give an initial indication of voltage security. A more revealing insight is offered by steady-state power transfer analysis [14]. A paucity of reactive power sources will decrease the power transfer capacity of the system, and will move normal operating points closer to the "nose" of the power-voltage (PV) curve, which indicates the point at which voltage security is jeopardised.

### III. TEST SYSTEM

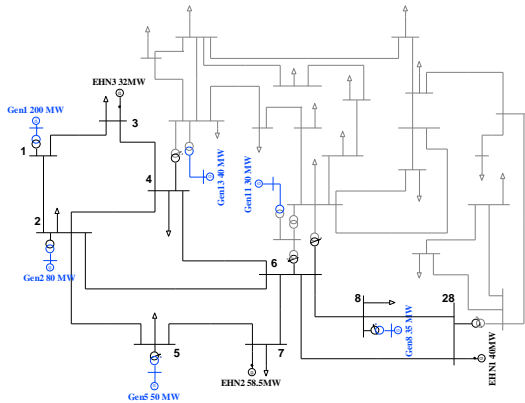

Fig. 2 Single line diagram for the test system. Transmission buses 3, 7 and 28 will accommodate EHN generation.

The IEEE 30 bus system, with voltage levels of 33 kV and 132 kV, recommends itself as a suitable test platform for the simulations in this study, based on its use for many similar studies (i.e [15]). The system characteristics are as given in [16], while [17] provides generator cost characteristics.

The six synchronous generators in the system are augmented in stages with three EHN generators to realise two wind energy penetration cases. These EHN generators inject

active power according to measured wind farm power output profiles, with the synchronous plant dispatched to serve the resulting nett load. This captures node specific effects of altered power flows caused by synchronous plant displacement. Fifteen minute granularity for load and generator time-series data will be used in this model, all taken from the year 2009 on the Irish power system [18]. Each conventional generator is modelled with an operating chart based on synchronous reactances of  $X_d = X_q = 1.75$  pu. (such as in [19]). Generator power factor is rated at 0.85. Inclusion of unit transformers accounts for the attenuation of reactive capability available at the transmission level.

This work proceeds under the assumption that two levels of future renewable energy penetration are to be planned for. In Case 1, 8.82% of load will be served by renewable generators: this is derived from EHN2, whose output is known from that of its constituent generators for the study year. For higher penetrations, Case 2 will also see the connection of EHN1 and EHN3, bringing total energy penetration to 20.04% for the year under study. The unit commitment tool will constrain on two units at all times, meaning that the minimum nett load that can be served is the sum of the lower stable power output limits of the two smallest units - in this case, 20 MW. A negligible amount of wind curtailment (0.01% by energy) is necessary in Case 2 to realise this.

### IV. EHN CHARACTERISATION RESULTS

The technique described in Section II-A is applied to the three EHNs to be used for this study, which are parameterised in Appendix A. Each EHN is based on an extant cluster of co-located wind farms for which historic output data is available. This implicitly captures the effect of output correlation among adjacent generators. Line impedances used within the model EHNs are consistent with the geographical disposition of the wind farms providing the source data.

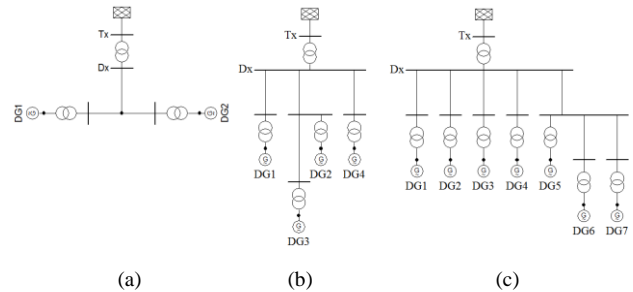

Fig. 3 Single line diagrams for EHN1 (a), located in the Southwest of Ireland, EHN2 (b) on the Northern seaboard and EHN3 (c) in the midlands.

The sending voltage and the permissible voltage limits on the network are of central importance in determining the voltage constraints on the system. This work assumed a maximum permissible voltage of 1.035 pu over the sending voltage of 1 pu. The maximum absorption case was constrained by machine limits (see Fig. 11) rather than voltage constraints. Of note is that distribution system operating standards directly affect the level of reactive support available to the transmission system, again emphasising that the

distribution system cannot be adequately studied in isolation.

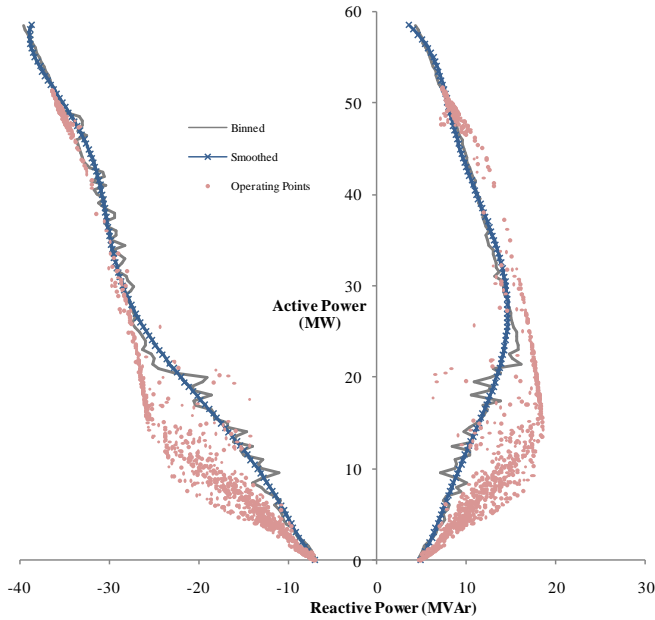

Fig. 4 Reactive power performance of EHN2, showing recorded (P, Q) points, the lines given by the percentile binning process, and the final characterisation as smoothed by a sixth order polynomial regression.

Note from Fig. 4 that for a given EHN aggregate active power output the range of reactive power operational points

recorded lies within reasonably tightly defined bands. This vindicates the EHN characterisation approach adopted. The statistical characterisation is performed with  $n$  set to 99%, and binning with  $g = 0.5$  MW.

The diversity in available reactive support for a given active power output arises from the myriad combination of individual generator outputs that may realise an aggregated EHN output, with each establishing its own set of voltage constraints and current loss profiles. Most notably, at higher active power outputs, voltage headroom is depleted and scope for export of reactive power is reduced. Furthermore, higher current loadings within the EHN increase reactive power losses, reducing the capability deliverable at the transmission node.

The capability characteristic in Fig. 4 gives a useful probabilistic description of the reactive capability expected from EHN2. As seen in Fig. 4, the raw results of the binned characterisation process are smoothed by a simple regression - in this case, a sixth order polynomial which achieved a  $R^2$  value of 0.95.

The work proceeds with equivalent descriptions of generators EHN1 and EHN3, presented, inter alia, in Section V.

## V. VOLTAGE CONTROL ADEQUACY PLANNING RESULTS

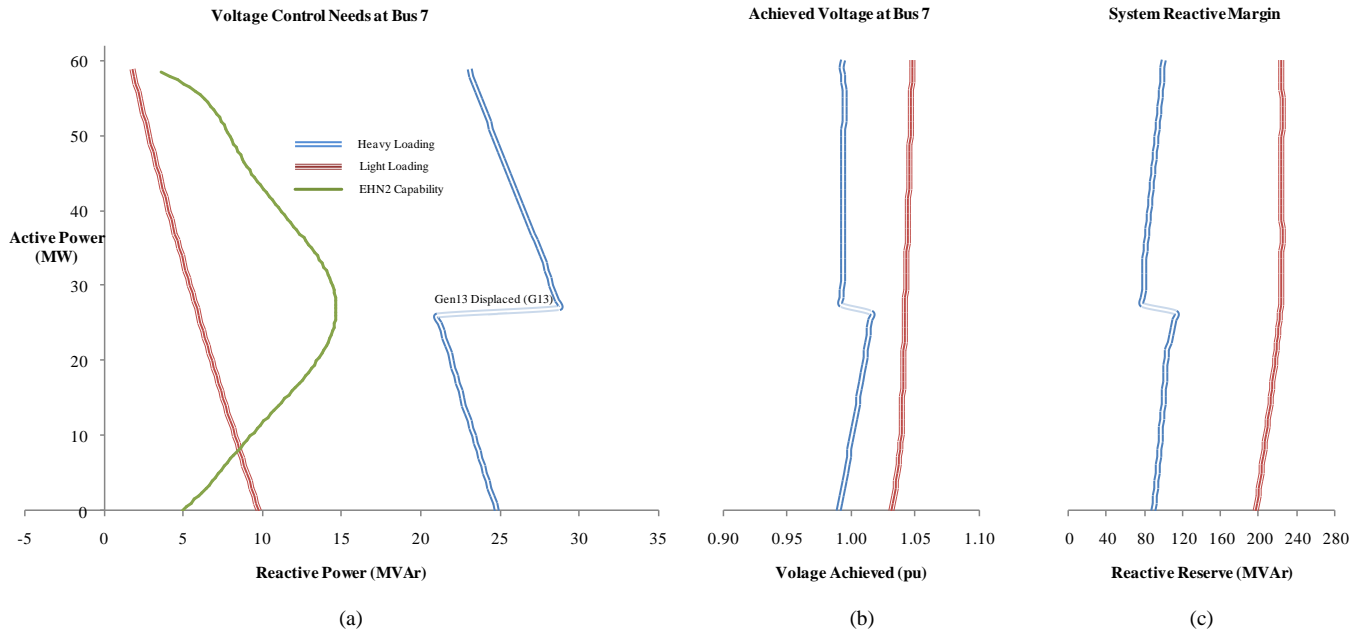

Fig. 5 Planning for Case 1: reactive power needs under various loading conditions for EHN2 operated as a must-run generator at bus 7

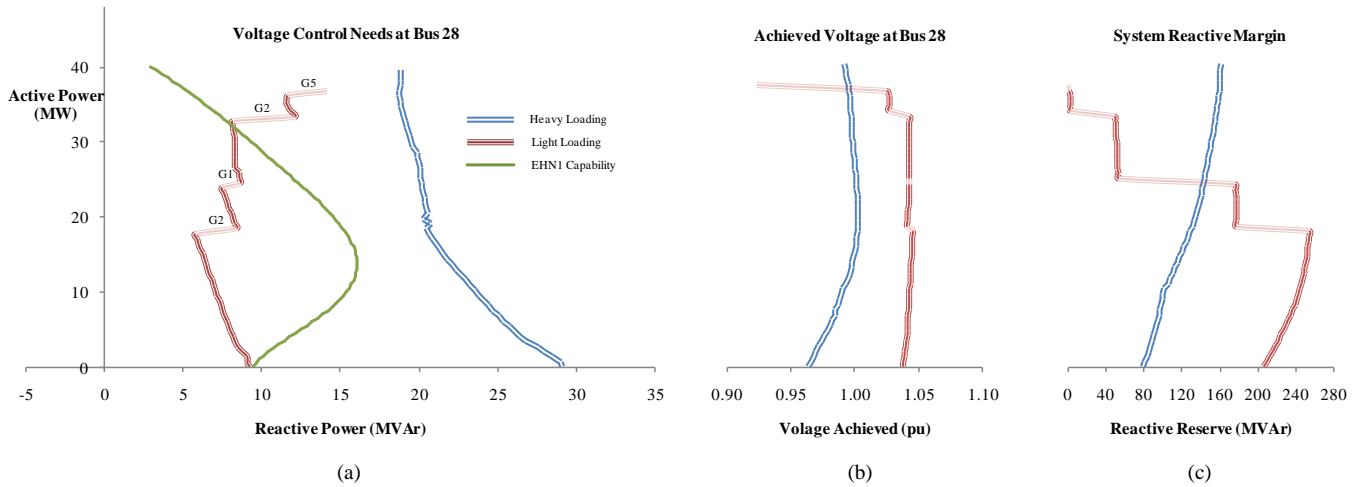

Fig. 6 Planning for Case 2: reactive power needs for various loading conditions for EHN1 at bus 28

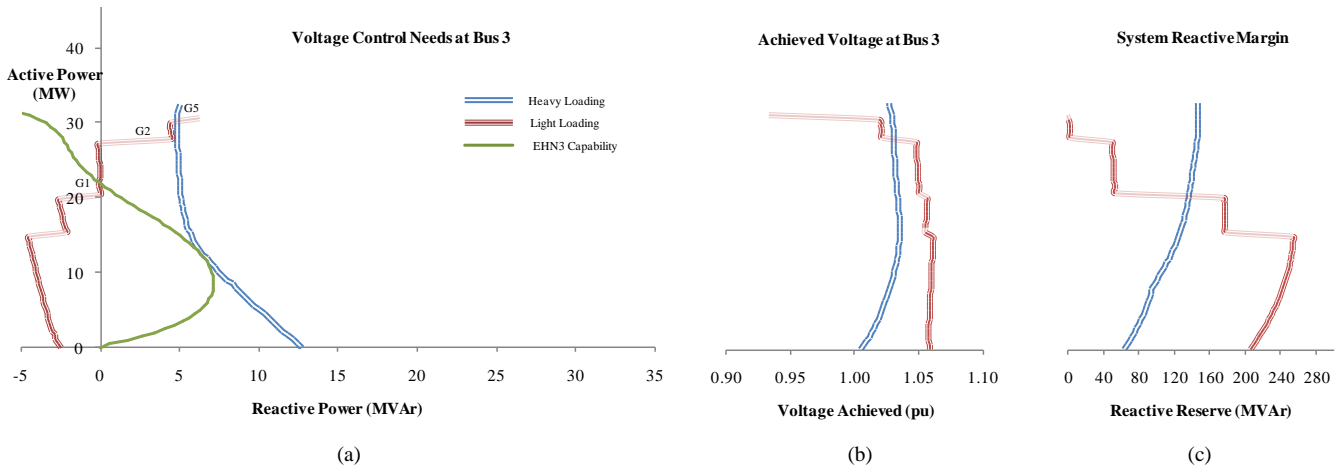

Fig. 7 Planning for Case 2: reactive power needs for various loading conditions for EHN3 at bus 3. The reactive capability of EHN3 is the most constrained, requiring import of reactive power at high output levels to satisfy distribution system voltage constraints

### A. Graph Structure

The results of the voltage control adequacy simulations are presented in Figs. 5, 6 & 7. Each graph shows application of the method applied under two representative system loading conditions. The "Heavy" loading corresponds to the 90th percentile level of system load for the study year, while "Light" conditions are the 10th percentile loading. For reference, each figure is overlaid with the reactive power capability used for the test generator: in Figs. 6 & 7 the characterisations of EHN1 and EHN3 are presented.

In producing these results, the test EHN generator is set to regulate voltage at the test bus to 1.05 pu, with 4% droop, on a rated  $Q$  of 50% of maximum active power output. The conventional plant in the system is modelled with equivalent droop settings but with a higher voltage set point of 1.1 pu. This acknowledges the fact that a transmission system operator will tolerate less stringent voltage control requirements from non-synchronous plant; an overly ambitious set point will result in continual operation at a machine limit, rather than linear control action. In each figure, pane (a) displays the reactive power required for the generator to enforce its voltage regulation slope, under the two loading conditions; the available capability plotted indicates if this is feasible. Pane (b) shows the voltage that would be achieved

using the available reactive power capability: this quantifies the effects of any reactive power shortfalls evident from pane (a). Finally, pane (c) displays the summation of spare reactive power available from units online on the system - this explicitly shows the reduction in reactive power margin resulting from conventional plant displacement.

### B. Predicted Case 1 Performance

Fig. 5 provides a variety of predictors of the system's voltage performance once it has been augmented with EHN2, to bring energy penetration to a level of 8.82%. The results are encouraging. In low loading conditions, EHN2 has a surfeit of reactive power capability, and the deficit in high loading conditions is minor - voltages achieved range between 0.99 and 1.05. The system reactive reserve metrics predict that at all times at least 90 MVar will be available on the system: EHN2's output will not displace enough synchronous plant to provoke voltage security concerns.

### C. Predicted Case 2 Performance

A more sophisticated scheme is required to plan the second stage of renewables expansion, seeing the connection of EHN1 and EHN3 shown in Fig. 6 & Fig. 7. For this voltage control adequacy assessment, a perfect proportional correlation between active power output of each wind EHN is assumed. With the existing renewable generator, EHN2,

operated as must-run plant, only the conventional plant is displaced as the output of each EHN rises. This provides voltage control adequacy charts for EHN1 at bus 28 and EHN3 at bus 3.

From Fig. 7 (a) it is readily apparent that for lower active power outputs of EHN3, there is sufficient reactive power capability to satisfy voltage control needs under typical loading conditions. The reactive power requirements are lessened by bus 3's electrical proximity to the large slack generator at bus 1. From Fig. 7 (c) it is also noteworthy that a large reactive power deficit may occur at high EHN active power output under low loading conditions, suggesting poor voltage performance. This is exacerbated by EHN3's requirement to import reactive power at times of high active power output to overcome its own internal distribution system voltage constraints.

Generally, the results of the planning assessment indicate that the integration of EHN2 in Case 1 will not be problematic, with achieved voltages and system reactive reserves remaining high. Under most conditions, Case 2 operation will be acceptable, though high EHN output levels under low loading conditions will erode available system reactive reserves, causing worryingly low achieved voltage levels.

## VI. TIME SERIES SIMULATION

### A. Initial Metrics

To simulate the performance of the test system with the EHN generation connected, a year of load flow calculations are performed, using the demand time series, the recorded EHN output and the generation unit commitment schedule to a resolution of fifteen minutes. In the simulations, each EHN is modelled as a P-V generator operating within the capability chart previously derived; the internal EHN network is not explicitly modelled.

An initial indication of transmission system voltage performance is gained by examination of recorded voltage maxima and minima for each penetration case.

TABLE I  
Transmission System Voltage Performance

	Max Volt.	Min. Volt	Avg. Volt
Base Case	1.0973	0.9041	1.0259
Case 1	1.0966	0.9176	1.0291
Case 2	1.0966	Infeasible/0.8872	1.0372

From Table I the metrics first suggest that the addition of EHN2 improves transmission system voltage profile in Case 1. This is consistent with Fig. 5 (a), showing a surfeit of reactive power capability under low loading conditions, and only a modest shortfall under heavy loading. This is vindicated by Fig. 5 (b), which predicts that EHN2 will typically be able to achieve a voltage between 1 and 1.05 pu. The presence of an additional, generally adequate voltage controller in the transmission system overcomes the negative effects of synchronous plant displacement, again emphasising the necessity of utilising reactive power from DG.

The results for Case 2 are more complex: most notably, in four periods no load flow convergence could be achieved, corresponding with times of maximum EHN penetration when reactive power loads could not be served. This fits with the circumstance predicted in Fig. 6 (c) and Fig. 7 (c) which show a near total depletion of system reactive reserve at times of low load and high EHN penetration.

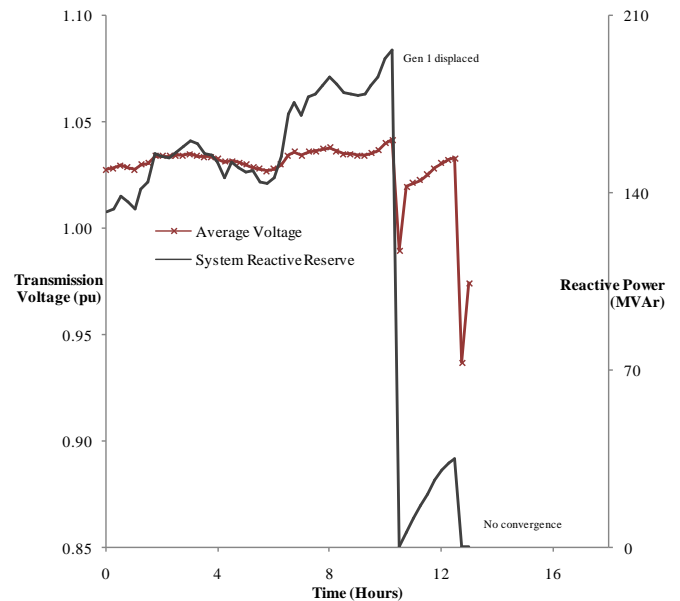

Fig. 8 A time series of the twelve hours leading up to the four period non-convergence event.

The proximate causes of the non-convergence event are depicted clearly in Fig. 8. It is immediately apparent that the displacement of the large Gen1 severely depleted system reactive power reserves, resulting initially in lowered voltage profiles and ultimately by four periods of non-convergence, corresponding to an insecure voltage operating regime. Other periods of minimal reactive power reserves for Case 2 resulted in voltages as low as 0.8872 pu.

While Table I clearly demonstrates that the very high instantaneous penetration levels (up to 90%) encountered in Case 2 jeopardise system voltage security, there is still an improvement in voltage performance for more typical operating states. The average voltage recorded at all transmission nodes over the entire year sees a reasonable improvement over that achieved for Case 1.

TABLE II  
Voltage Performance at Bus 28

	Max Volt.	Min. Volt	Avg. Volt
Base Case	1.0443	0.9103	0.9963
Case 1	1.0398	0.9236	0.9992
Case 2	1.0455	Infeasible/0.9174	1.0167

The specific voltage performance for bus 28 is provided in Table II, which permits direct comparison with Fig. 6. Considering Case 2, when EHN1 is first connected, the lowest recorded voltage is 0.9174 pu. This is consistent with the low loading, high power output case shown in Fig. 6 (b). The

maximum achieved voltage of 1.0455 pu corresponds well with the voltage achieved for low power outputs under these conditions.

### B. Voltage Security Analysis

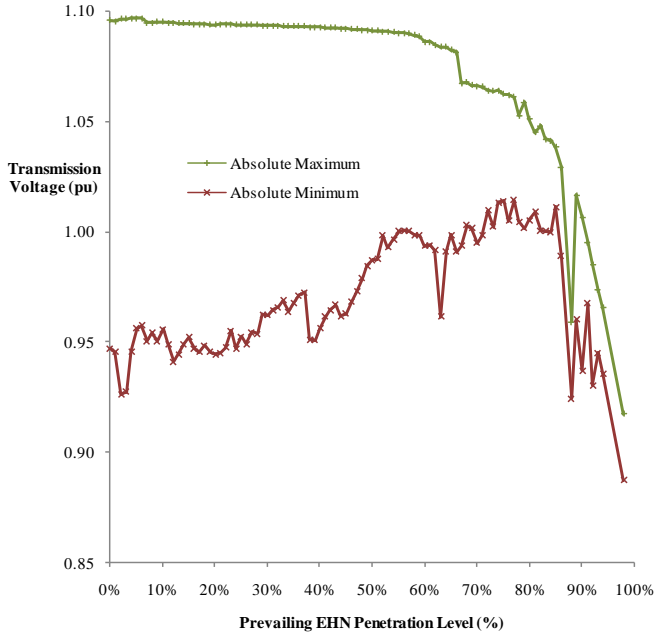

Fig. 9 Raising EHN penetration levels and resulting voltage performance for Case 2.

The relationship between instantaneous penetration levels of EHN generators and adequacy of voltage control performance is central to this work. Fig. 9 permits identification of the penetration level at which voltage performance may become operationally unacceptable. The figure is populated by a binning process with a granularity of 1%, and shows the maximum and minimum voltages recorded at any node for any period with the corresponding EHN penetration level. A decline of maximum recorded voltage is immediately apparent at the ~65% level, falling from the 1.1 pu value that corresponds to the regulated set-point of the conventional generators. From here to the closing 98% level, maximum voltages decline rapidly, with minimum achieved voltages joining the decline from the ~90% level. The operating regime which sees consistently low voltage extrema above 65% penetration strongly suggests an insecure power system, where voltage instability and collapse appears likely.

The rising trend in minimum achieved voltages up to the ~80% penetration level is a notable result. This mirrors the rise in average voltages seen for each case in Table I, and can also be predicted from Figs. 5, 6 & 7 (a), where there is generally adequate reactive power capability to control voltages under low loadings and penetrations. The substantial reductions in system reactive reserves seen in the (c) panes only occur under relatively rare low loadings and high EHN power output conditions, and it is this paucity of reserve that accounts for degraded voltage performance, as seen in Fig. 9. This substantial reduction in voltage performance above a certain penetration level again emphasises the need for transmission system planners to take full account of the effects of synchronous plant displacement.

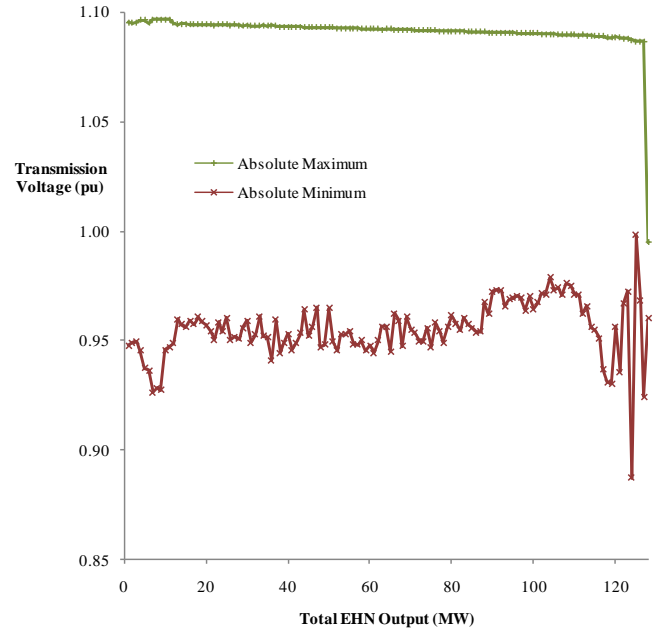

Fig. 10 Relationship between voltage performance and total EHN output power for Case 2.

To investigate if times of high EHN output are inherently problematic to the transmission system, in Fig. 10 the same data set used in Fig. 9 is presented, but binned instead on 1 MW increments of aggregate EHN output power. Of note from Fig. 10 is the comparative flatness of each trace, demonstrating no overt link between high EHN output levels and degraded voltage performance, save for the closing data points at the extreme right of the graph where corresponding high penetration levels are inevitable.

## VII. CONCLUSIONS

The planning methodology provided has been shown to offer useful insight into the anticipated voltage control contribution of suitably characterised distributed resources. The results of the validating time series simulations draw out the complex relationship between instantaneous penetration levels and transmission system voltage performance. Most notably, it has shown for the test power system that it is only at high penetration levels that the benefit of having additional voltage controllers in the transmission system is eroded by the effect of conventional plant displacement. This type of analysis can provide useful insight to power system operational practice, indicating the level of instantaneous renewable penetration that can be securely accommodated, and thus implying the point at which renewables curtailment becomes apposite.

Given the efficacy of the methodologies presented, there is scope for further work to extend the characterisation approach to a broader class of distributed resources, to cover generators embedded in load-serving networks. Equally, application of the planning methodology to a wider range of test transmission systems may offer additional insight. This work has provided an encapsulated description of the combined reactive power capabilities of disparate plant: similar characterising abstractions in areas such as fault current contribution and dynamic performance may facilitate

improved consideration of distributed resources in holistic power system planning.

## APPENDIX A

### A. EHN1

Gen.	Own Feeder				Rating	
Branch	Length (km)	R <sub>1</sub> (Ω)	X <sub>1</sub> (Ω)	B' (μS)	P <sub>rated</sub> (MW)	Q class
DG1	4.71	0.221	0.518	399.3	22.5	A
DG2	4.38	0.205	0.481	371.3	17.2	B
To Tee	19.54	0.918	2.149	1656	N/A	N/A

Trafo	S <sub>rated</sub> (MVA)	V <sub>Hi</sub> (kV)	V <sub>Lo</sub> (kV)	Shc Volt. (%)	X/R
Grid	63	110	41	19	42.21
DG1	25.00	38.5	20	10	16
DG2	20.00	38.5	20	9.82	20

### B. EHN2

Gen.	Own Feeder			Rating	
Branch	Length (km)	R <sub>1</sub> (Ω)	X <sub>1</sub> (Ω)	P <sub>rated</sub> (MW)	Q class
DG1	7.45	0.820	1.304	32	C
DG2	14	2.548	5.110	14	D
DG3	1.7	0.894	0.680	4.8	C
DG4	14	7.364	5.628	5	C

Trafo	S <sub>rated</sub> (MVA)	V <sub>Hi</sub> (kV)	V <sub>Lo</sub> (kV)	Shc Volt. (%)	X/R
Grid	63	110	41	15.86	38.11
DG1	41.00	41	20	8	20
DG2	15.00	41	20	8	20
DG3	5.50	41	20	8	20
DG4	6.00	41	20	8	20

### C. EHN3

Gen.	Own Feeder			Rating	
Branch	Length (km)	R <sub>1</sub> (Ω)	X <sub>1</sub> (Ω)	P <sub>rated</sub> (MW)	Q class
DG1	7.75	3.178	3.18	5	E
DG2	5.07	2.079	2.08	6.8	E
DG3	5.03	2.062	2.06	7.65	E
DG4	7.25	5.51	3.84	4.25	E
DG5	8.38	1.718	1.72	3.4	E
DG6	4.74	3.602	2.51	3.4	E
DG7	4.4	1.804	1.8	5.1	E

Trafo	S <sub>rated</sub> (MVA)	V <sub>Hi</sub> (kV)	V <sub>Lo</sub> (kV)	Shc Volt. (%)	X/R
Grid	20	110	21	9.3	25.12
DG1	5.56	21	10	5.5	14
DG2	7.56	21	10	5.5	15
DG3	8.50	21	10	5.5	16
DG4	4.72	21	10	5.5	14
DG5	3.78	21	10	5.5	14
DG6	3.78	21	10	5.5	14
DG7	5.67	21	10	5.5	14

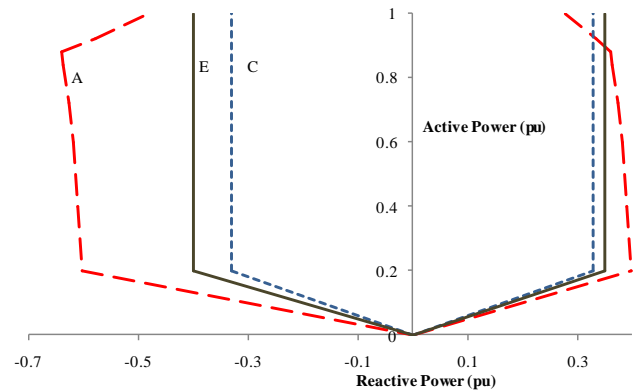

Fig. 11 Reactive power operating charts used for EHN constituent DGs. Class B can achieve between -0.49 and 0.33 pu reactive power regardless of active power; Class D between -0.45 and 0.35.

## ACKNOWLEDGEMENTS

The authors acknowledge the contribution of Aonghus Shortt to the unit commitment portion of this work. The cooperation of ESB Networks and Eirgrid is also acknowledged.

## REFERENCES

- [1] EirGrid Plc., *Facilitation of Renewables WP3 Final Report*, June 2010 available at [www.eirgrid.com](http://www.eirgrid.com)
- [2] Clark, K.; Miller, N.; "WindFREE reactive power control for wind-turbine generators", Nordic Wind Power Conference, Espoo, Finland May 2006
- [3] Keane, A.; Ochoa, L. F.; Vittal, E.; Dent, C. J.; Harrison, G. P.; , "Enhanced Utilization of Voltage Control Resources With Distributed Generation," *Power Systems, IEEE Transactions on*, January 2010
- [4] Senjyu, T.; Miyazato, Y.; Yona, A.; Urasaki, N.; Funabashi, T.; , "Optimal Distribution Voltage Control and Coordination With Distributed Generation," *Power Delivery, IEEE Transactions on*, vol.23, no.2 April 2008
- [5] Gubina, A. F.; Gubina, F.; Golob, R.; "Intelligent coordinative voltage and reactive power control" *International Journal of Electrical Power & Energy Systems*, May 2001
- [6] Tsili, M.; Papathanassiou, S.; , "A review of grid code technical requirements for wind farms," *Renewable Power Generation, IET*, vol.3, no.3, Sept. 2009
- [7] Vittal, E.; O'Malley, M.; Keane, A.; , "Impact of wind turbine control strategies on voltage performance," *Power & Energy Society General Meeting, 2009.IEEE PES '09*
- [8] Wenjuan Zhang; Fangxing Li; Tolbert, L.; , "Review of reactive power planning: objectives, constraints, and algorithms," *Transmission and Distribution Conference and Exposition, 2008. IEEE/PES, 21-24 April 2008*
- [9] Smith, P.; Cuffe, P.; Grimes, S.; Hearne, T.; , "Ireland's approach for the connection of large amounts of renewable generation," *Power and Energy Society General Meeting, 2010 IEEE*
- [10] Cuffe, P.; Smith, P.; Keane, A.; , "Analysis of the Voltage Control Capability of Energy Harvesting Networks", *9th International Workshop on*

*large Scale Wind Integration*, Quebec, Canada, October 2010

- [11] Losi, A.; Russo, M.; Verde, P.; Menniti, D.; "Capability chart for generator-transformer units," Electrotechnical Conference, 1996. MELECON '96., 8th Mediterranean
- [12] Shortt, Aonghus; Kiviluoma, Juha; O'Malley, Mark; "Commit: a general purpose mixed-integer unit-commitment & dispatch model", (Working paper), available: <http://erc.ucd.ie/files/perma/commit.pdf>
- [13] Yuanning Wang; Wilsun Xu;"An investigation on the reactive power support service needs of power producers," Power Systems, IEEE Transactions on , vol.19, no.1, Feb. 2004
- [14] C. Taylor *Power System Voltage Stability*, Dallas, TX:McGraw-Hill, 1993
- [15] Meegahapola, L.; Durairaj, S.; Flynn, D.; Fox, B.; " Coordinated utilisation of wind farm reactive power capability for system loss optimisation", *European Transactions on Electrical Power*, March 2010
- [16] Alsac, O.; Stott, B.; , "Optimal Load Flow with Steady-State Security," Power Apparatus and Systems, IEEE Transactions on , May 1974
- [17] Raglend, I.J.; Padhy, N.P.; , "Solutions to practical unit commitment problems with operational, power flow and environmental constraints," Power Engineering Society General Meeting, 2006. IEEE
- [18] EirGrid, "System Demand", [Online], available: <http://www.eirgrid.com/>
- [19] P. Kundur, *Power System Stability and Control*, London, UK, McGraw-Hill, 1994

**Paul Cuffe** received the BE (Electrical) in 2009. He is currently pursuing a PhD in the Electricity Research Centre, University College Dublin (UCD), Ireland. His research interests are voltage control techniques for distributed networks with significant renewable penetration.

**Paul Smith** is a SFI Charles Parsons Award Researcher in the Electricity Research Centre, UCD, Ireland. He graduated with BE and MIE degrees from UCD and spent over 35 years in the electricity industry dealing with system planning and operations issues. He is a Distinguished Member of CIGRÉ and an invited expert member of the CIGRÉ Study Committee on System Development and Economics.

**Andrew Keane** received B.E. and Ph.D. degrees in Electrical Engineering from University College Dublin in 2003 and 2007 respectively. He is currently a lecturer with the School of Electrical, Electronic and Communications Engineering, University College Dublin, Ireland, with research interests in power systems planning and operation, distributed energy resources and distribution networks.