



<b>Title</b>	A fully integrated 28nm Bluetooth low-energy transmitter with 36% system efficiency at 3dBm
<b>Authors(s)</b>	Kuo, Feng-Wei, Babaie, Masoud, Chen, Ron, Staszewski, Robert Bogdan, et al.
<b>Publication date</b>	2015-09-18
<b>Publication information</b>	Kuo, Feng-Wei, Masoud Babaie, Ron Chen, Robert Bogdan Staszewski, and et al. "A Fully Integrated 28nm Bluetooth Low-Energy Transmitter with 36% System Efficiency at 3dBm." IEEE September 18, 2015. <a href="https://doi.org/10.1109/ESSCIRC.2015.7313901">https://doi.org/10.1109/ESSCIRC.2015.7313901</a> .
<b>Conference details</b>	ESSCIRC 2015 - 41st European Solid-State Circuits Conference (ESSCIRC), Graz, Austria, 14 - 18 September 2015
<b>Publisher</b>	IEEE
<b>Item record/more information</b>	<a href="http://hdl.handle.net/10197/7334">http://hdl.handle.net/10197/7334</a>
<b>Publisher's statement</b>	© © 2015 IEEE. Personal use of this material is permitted. Permission from IEEE must be obtained for all other uses, in any current or future media, including reprinting/republishing this material for advertising or promotional purposes, creating new collective works, for resale or redistribution to servers or lists, or reuse of any copyrighted component of this work in other works.
<b>Publisher's version (DOI)</b>	10.1109/ESSCIRC.2015.7313901

Downloaded 2026-05-02 00:27:21

The UCD community has made this article openly available. Please share how this access benefits you. Your story matters! (@ucd\_oa)



© Some rights reserved. For more information



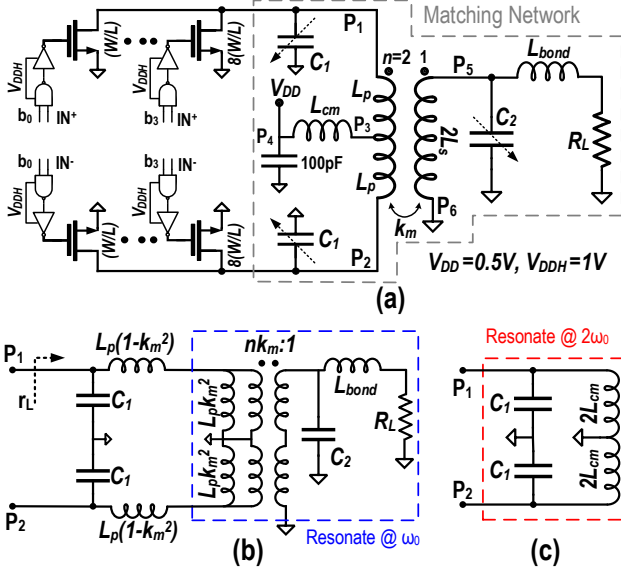

Fig. 2. (a) Class-E/F<sub>2</sub> switching PA. PA's matching network equivalent circuit for (b) differential, and (c) common-mode excitations.

TABLE I  
 $F_C \cdot F_I^2$  FOR DIFFERENT FLAVORS OF CLASS-E/F PA

	E	E/F <sub>2</sub>	E/F <sub>3</sub>	E/F <sub>2,3</sub>	E/F <sub>4</sub>	E/F <sub>2,4</sub>	E/F <sub>3,4</sub>	E/F <sub>5</sub>
$F_C \cdot F_I^2$	7.44	2.47	7.25	4.99	5.88	2.06	5.06	7.35

have the same DC gate voltage,  $M_{3,4}$  sub-threshold operation also provides enough  $V_{OD}$  overdrive for the switching current source devices  $M_{1,2}$  to operate in the saturation region at the DC operating point. Hence, unlike traditional oscillators, the dimension of  $M_{3,4}$  devices must be a few times (i.e.,  $8\times$ ) larger than current source devices to guarantee their weak-inversion operation. Furthermore, the oscillation swing cannot go further than  $V_{OD1,2}$  at DA/DB nodes, which is chosen  $\sim 150$  mV to satisfy the system's phase noise spec by a few dB margin. Consequently, as with cross-coupled NMOS oscillator, the proposed structure can operate at  $V_{DD}$  as low as 0.5 V.

The transformer voltage gain ( $A$ ) enhances the oscillation swing at  $M_{1-4}$  gates to even  $>V_{DD}$  and guarantees the start-up over PVT variations. Furthermore, the combination of  $A$  and the effective trans-conductance gain of  $M_{1-4}$  must compensate the tank losses. Hence, the contribution of  $M_{1-4}$  to the oscillator PN reduces by  $A$ , which compensates the effect of lower voltage efficiency ( $\alpha_V$ ) of this structure on the oscillator PN and FoM.

Larger tank input impedance,  $R_p$  is also beneficial to reduce the oscillator's power consumption.  $R_p$  reaches its maximum when  $L_s C_s / L_p C_p = 1$  for  $Q_p \approx Q_s$ . Hence, the PVT tuning capacitors are divided in the transformer's primary and secondary to roughly satisfy this criterion.

Switching the bias of  $M_{1-4}$  devices reduces both their  $1/f$  noise and also the DC component of their effective ISF function. Consequently, a much lower  $1/f^3$  PN corner is expected than in the traditional oscillators [1].

### III. CLASS-E/F<sub>2</sub> POWER AMPLIFIER

Designing a fully integrated PA optimized for low output power ( $P_{out} < 3$  dBm) with PAE  $> 40\%$  is very challenging, especially when differential structure is needed to satisfy

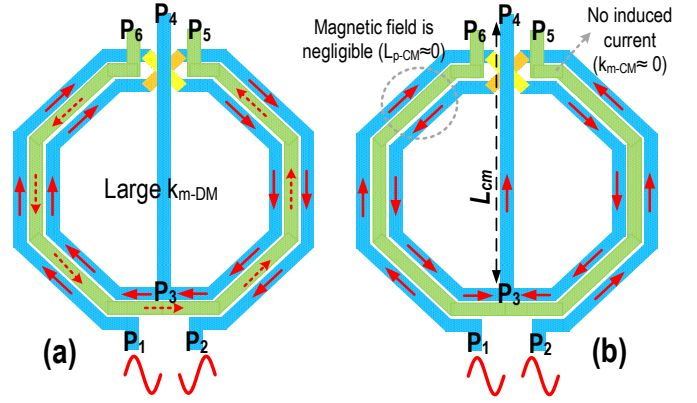

Fig. 3. Behavior of 2:1 step-down transformer in (a) differential-mode, and (b) common-mode excitations.

the stringent 2<sup>nd</sup> harmonic emissions. To realize such a low  $P_{out}$ , one needs to employ a matching network with a large impedance transformation ratio (ITR) to increase the load resistance,  $r_L$ , seen by the PA transistor drains of Fig. 2.

$$ITR = r_L / R_L = 0.5 \cdot n^2 \cdot k_m^2 \quad (2)$$

Unfortunately, the differential structure and imperfect magnetic coupling factor  $k_m$  of the matching network's transformer exhibit reverse effect of reducing  $r_L$  and thus ITR. Hence, the transformer turns ratio ( $n:1$ ) should be large  $n > 4$  to compensate for them. However, Q-factor of transformer windings, and thus its efficiency, drops dramatically with  $n > 2$ . Consequently, the PAE of published integrated PAs is relatively low ( $< 30\%$ ) or off-chip components are used in their matching networks [2]-[6].

The drain efficiency  $\eta_D$  of class-E/F switch-mode PA can be calculated by [7]

$$\eta_D = \frac{(C_{out}/C_1)}{(C_{out}/C_1) + F_C F_I^2 R_{on} C_{out} \omega_0} \quad (3)$$

where,  $C_1$  is PA's required shunt capacitance to satisfy class-E/F zero-voltage and zero-slope (ZVS) switching [8].  $R_{on}$  and  $C_{out}$  are, respectively, on-state channel resistance and output capacitance of  $M_1$  transistor. Note that  $R_{on} \times C_{out}$  is a constant at a given technology and invariant to changes of  $M_1$ 's width.  $F_I$  is defined as ratio of RMS over DC values of  $M_1$  drain current.  $F_C$  is the PA waveform factor. Both  $F_I$  and  $F_C$  are merely a function of matching network strategy and do not change over technology or PVT variations [8].

A smaller  $P_{out}$  can also be realized by using a lower  $V_{DD}$  for the PA's drains (e.g., 0.5 V) without any degradation of  $\eta_D$ , as gathered from (3). As a consequence, the required ITR will be smaller, which results in better efficiency of PA's switching network. Furthermore, the drain voltage of the switching transistor is also limited to  $\leq 1.5$  V, alleviating reliability issues due to gate-oxide breakdown [9]. Eq. (3) also indicates that the switching amplifiers with smaller  $F_C \cdot F_I^2$  (see Table I) inherently demonstrate higher efficiency. For example, class-E PA efficiency can be improved by realizing an additional open circuit as the PA switches' effective load at 2<sup>nd</sup> harmonic  $2\omega_0$  (i.e., class-E/F<sub>2</sub> operation). Furthermore, class-E/F<sub>2</sub> shows a better tolerance to  $C_{out}$  variations [7] due to the role of 2<sup>nd</sup> harmonic tuning in smoothing the drain voltage waveform [8]. These benefits come at the expense of

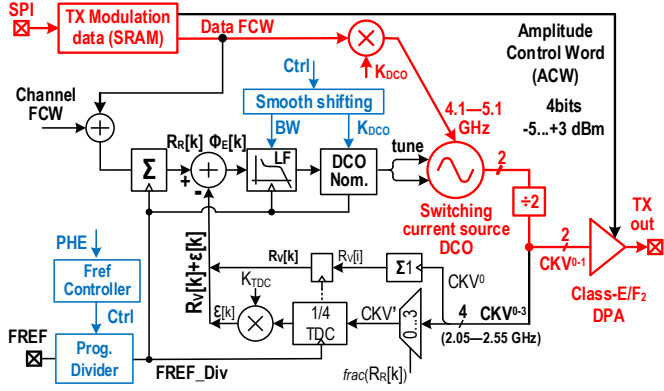

Fig. 4. Block diagram of the 2.4GHz ULP Bluetooth low-energy transmitter.

$\sim 3\times$  lower power gain for PA transistors compared to that in the conventional class-E setup. However, the power gain of 28nm NMOS devices is high enough at relatively low frequency of 2.4 GHz such that a 4.5 dB power gain penalty has a negligible effect on the total system efficiency.

Fig. 2(b) shows the equivalent circuit of the PA matching network in the differential mode. The transformer's secondary inductance  $2L_s$  and capacitor  $C_2$  resonate at  $\omega_0$  to optimize the matching network efficiency. Furthermore, the transformer's leakage inductance  $L_p(1 - k_m^2)$  and primary capacitor  $C_1$  respectively realize the required series inductance and shunt capacitance of a class-E/F PA to satisfy its ZVS switching criteria.

As illustrated in Fig. 3, the step-down 2:1 transformer acts differently to the common-mode (CM) and differential-mode (DM) input signals. When the transformer's primary is excited by a CM signal at  $2\omega_0$  [Fig. 3(b)], the magnetic flux excited within two turns of the primary winding cancels itself out. Consequently, the transformer's primary inductance is negligible and no current is induced at the transformer's secondary ( $k_{m-CM} \approx 0$ ). Hence,  $R_L$ ,  $L_s$  and  $C_2$  cannot be seen by the  $2\omega_0$  component of drain current. Furthermore, CM inductance seen by PA transistors is mainly determined by the dimension of the trace between the transformer center-tap and decoupling capacitors at the  $V_{DD}$  node, which roughly must resonate with  $C_1$  at  $2\omega_0$  to realize the class-E/F<sub>2</sub> operation (see Fig. 2 (c)).

#### IV. ALL-DIGITAL PHASE-LOCKED LOOP ARCHITECTURE

Fig. 4 shows a block diagram of the proposed ultra-low power (ULP) all-digital PLL (ADPLL) adapted from a high-performance cellular 4G ADPLL [10]. The  $\sim 2.45$  GHz  $\div 2$  divider output of 4 phases,  $CKV^{0-3}$ , oversamples the frequency reference (FREF: 1–50MHz) generating  $CKR^{0-3}$  vector clock to sample the variable DCO phase  $Rv[k]$  to calculate the phase error,  $\phi_E[k]$ . To avoid metastability in FREF retiming, FREF is simultaneously oversampled by different phases of CKV and an edge selection signal chooses the path farther away from metastability. The  $\phi_E[k]$  is fed to the type-II loop filter (LF) with 4th order IIR. The LF is dynamically switched during frequency acquisition to minimize the settling time while keeping the phase noise (PN) at optimum. The built-in DCO gain,  $K_{DCO}$ , and TDC gain,  $K_{TDC}$ , calibrations are autonomously performed to ensure the wideband FM response.

The long string of 417 ps/7 ps  $> 60$  inverters is shortened 4x by running the DCO at 2x the carrier frequency and dividing

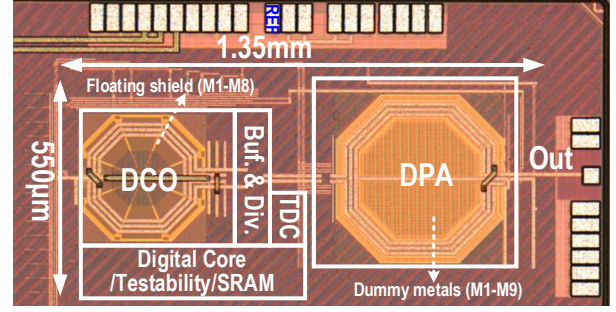

Fig. 5. Die micrograph of the proposed ULP transmitter.

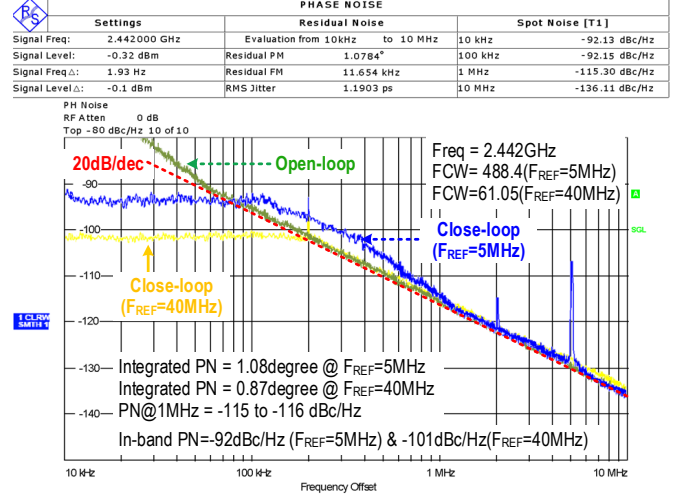

Fig. 6. Transmitter phase noise in open-loop and different close-loop configurations.

its output by 2 to create a CKV clock vector,  $CKV^{0-3}$ . A phase predictor ensures the TDC input  $CKV'$  is  $< T_V/4$  by selecting a CKV phase that is closest to FREF. The TDC output, after decoding, is normalized to  $T_V$  by the  $\Delta_{TDC}/T_V$  multiplier and the octal estimation, normalized to  $T_V/4$ , is added to produce the phase error  $\phi_E$ . The DCO tuning word is updated based on  $\phi_E$ .

The following architectural innovations allow the ADPLL to support ULP operation (highlighted in blue): The effective sampling rate of the phase detector and its related DCO update is dynamically controlled by scaling-down the frequency reference (FREF) clock and simultaneously adjusting the loop gain. During ADPLL settling, the full FREF rate is used, but afterwards its rate could get substantially reduced (e.g., 8x), thus saving power consumption of the digital circuitry. The resulting in-band PN degradation is tolerable due to low PN of the DCO. In fact, freezing FREF would incur sufficiently low frequency drift during Bluetooth 625 $\mu$ s packets, while keeping in operation the bare minimum of circuitry highlighted in red.

#### V. MEASUREMENT RESULTS

Fig. 5 shows the die photo of the 0.75mm<sup>2</sup> ULP TX in TSMC 1P9M 28nm CMOS. Both DCO and PA transformer's windings are realized with top ultra-thick metal. However, they include a lot of dummy metal pieces on all metal layers (M1–M9) to satisfy very strict minimum metal density manufacturing rule of advanced ( $\leq 28$  nm) technology nodes.

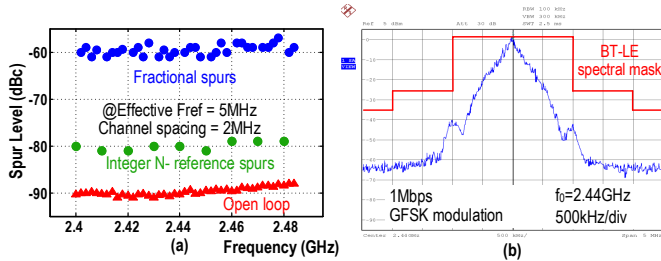

Fig. 7. (a) ADPLL fractional, reference and open-loop spurs; (b) Bluetooth GFSK modulation spectrum.

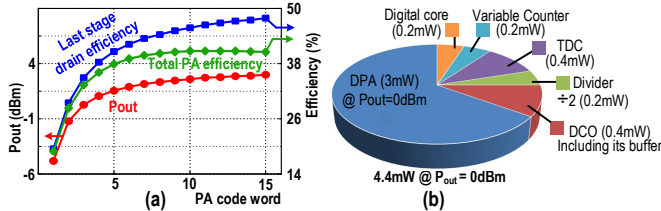

Fig. 8. (a) PA characteristics; (b) TX power breakdown at  $P_{out}=0$  dBm.

Fig. 6 displays the phase noise plot of the proposed transmitter at different configurations. The measured DCO PN is  $-116$  dBc/Hz at 1 MHz offset from 2.442 GHz carrier (green line in Fig. 6) while consuming 0.4 mW from 0.5 V power supply. Thanks to the switching current source technique,  $1/f^3$  PN corner of the oscillator is extremely low (i.e.  $\leq 100$  kHz) across the tuning range (TR). The oscillator has a 22% TR, from 4.1-to-5.1 GHz. its average FoM is 188 dBc and varies  $\sim 1$  dB across the TR. As expected, the DCO also shows very low supply frequency pushing of 10-12 MHz/V, thus making it suitable for direct connection to solar cells and integration with PA.

When used as LO at *undivided* 40 MHz FREF, the ADPLL consumes 1.4 mW. It settles in  $20 \mu\text{s}$ , and exhibits in-band PN of  $-101$  dBc/Hz with integrated PN of  $0.87^\circ$ , as shown by yellow line in Fig. 6. Thanks to the low wander of the DCO, digital power consumption of the rest of ADPLL can be saved by scaling the rate of sampling clock to 5 MHz. However, the in-band PN increases to  $-92$  dBc/Hz with integrated PN of  $1.08^\circ$  (blue line in Fig. 6). The reference spur is  $-80$  dBc and the worst-case fractional spur is  $-60$  dBc at BT-LE channels as shown in Fig. 7(a). Fig. 7(b) shows Bluetooth-LE 1 Mb/s GFSK modulation provided by the ADPLL, while fulfilling all spectrum mask requirements with sufficient margin.

PA output level is adjustable between  $-5$  to  $+3$  dBm and reaches excellent peak PAE of 41% (see Fig. 8(a)). The proposed TX consumes 3.6/5.5 mW during the open-loop 1 Mb/s GFSK BT-LE modulation at 0/3 dBm output, resulting in  $\eta_{TX}=28/36\%$  total TX efficiency. The power consumption would increase by 0.8 mW with TDC, variable counter and digital circuitry turned on when the ADPLL is clocked at 40 MHz FREF. Thus, even in closed loop, with  $\eta_{TX}=23/32\%$  at 0/3dBm it is still 1.5x better than the prior record. The TX power breakdown is also illustrated in Fig. 8 (b).

Table II summarizes the performance and compares it with leading ULP transmitters. The proposed ULP TX achieves the lowest power consumption and PN.

TABLE II  
PERFORMANCE SUMMARY AND COMPARISON WITH STATE-OF-THE-ART.

	This work	ISSCC'13 IMEC [2]	ISSCC'12 Toumaz[3]	ESSCIRC'14 Frontier[4]	ISSCC'15 Dialog[5]	ISSCC'15 Renesas[6]		
CMOS technology	28nm	90nm	130nm	65nm	55nm	40nm		
OSC PN @1MHz (dBc/Hz)	-116	-111	-107	-108.2	N/A	N/A		
OSC FoM (dB)	188	183	N/A	N/A	N/A	N/A		
PLL in-band PN (dBc/Hz)	-92 @ FREF=5MHz	-85	-87	-87.5	N/A	N/A		
	-101 @ FREF=40MHz							
Integrated PN (degree)	1.08 @ FREF=5MHz	2.3	N/A	N/A	N/A	N/A		
	0.87 @ FREF=40MHz							
Output power (dBm)	-5 to +3	-23 to -1	-30 to +5	-10 to -3	-20 to 0	0		
Maximum PA PAE	41%	25%	N/A	<25%	<25%	<25%		
On-chip matching network	Yes	No	No	No	Yes	Yes		
Supply voltage (V)	0.5 / 1	1.2	1	1.1	0.9-3.3	1.1		
	@ $P_{out}$	0dBm 3dBm	-1dBm 0dBm	-3dBm 0dBm	0dBm 0dBm	0dBm 0dBm		
Power consumption (mW)	open-loop	3.6	5.5	5.4	8.9	5.1	10.1	7.7
	close-loop	4.4	6.3					
TX efficiency ( $P_{out}/P_{dc}$ )	open-loop	28%	36%	15%	12%	10%	10%	13%
	close-loop	23%	32%					

## VI. CONCLUSION

We have proposed an ultra-low power Bluetooth LE transmitter that demonstrates the best ever reported power efficiency and phase purity, while abiding by the strict 28 nm CMOS technology manufacturing rules. A new switching current source oscillator combines advantages of low supply voltage of the conventional NMOS cross-coupled oscillator with high current efficiency of the complementary push-pull oscillator to reduce the oscillator supply voltage and dissipated power further than practically possible in the traditional oscillators. Furthermore, due to the low wander of DCO, digital power consumption of ADPLL was saved by scaling the rate of sampling clock to the point of its complete shut-down. A fully integrated differential class-E/F<sub>2</sub> switching PA is utilized to improve system efficiency at low output power of 0–3 dBm. Its required matching network was realized by exploiting different behaviors of a 2:1 step-down transformer in differential and common-mode excitations.

## REFERENCES

- [1] M. Babaie, *et al.*, "A 0.5 V 0.5 mW switching current source oscillator," *IEEE RFIC Symp.*, 18 May 2015. (accepted)
- [2] Y. H. Liu, *et al.*, "A 1.9nJ/b 2.4GHz multistandard (Bluetooth low energy/Zigbee/IEEE802.15.6) transceiver for personal/body-area networks," in *IEEE ISSCC*, Feb. 2013, pp. 446–447.
- [3] A. Wang, *et al.*, "A 1V 5mA multimode IEEE 802.15.6/Bluetooth low-energy WBAN transceiver for biotelemetry applications," in *IEEE Int. Solid-State Circuits Conf. Dig Tech. Papers*, Feb. 2012, pp. 300–301.
- [4] G. Devita, *et al.*, "A 5mW multi-standard Bluetooth LE/IEEE 802.15.6 SoC for WBAN applications" in *Proc. Eur. Solid State Circuits Conf.*, Sep. 2014, pp. 283–286.
- [5] J. Prummel, *et al.*, "A 10mW Bluetooth low-energy transceiver with on-chip matching" in *IEEE Int. Solid-State Circuits Conf. Dig Tech. Papers*, Feb. 2015, pp. 238–239.
- [6] T. Sano, *et al.*, "A 6.3mW BLE transceiver embedded RX image-rejection filter and TX harmonic-suppression filter reusing on-chip matching network" in *IEEE Int. Solid-State Circuits Conf. Dig Tech. Papers*, Feb. 2015, pp. 240–241.
- [7] M. Babaie, *et al.*, "A wideband 60 GHz class-E/F<sub>2</sub> power amplifier in 40nm CMOS," *IEEE RFIC Symp.*, 18 May 2015. (accepted)
- [8] S. Kee, *et al.*, "The class-E/F family of switching amplifiers," *IEEE Trans. Microwave Theory Tech.*, vol. 51, no. 6, pp. 1677–1690, June 2003.
- [9] M. Babaie and R. B. Staszewski, "A study of RF oscillator reliability in nanoscale CMOS," *Proc. of IEEE 21<sup>st</sup> European Conference on Circuit Theory and Design (ECCTD)*, Sept. 2013, pp. 243–246.
- [10] F. W. Kuo, *et al.*, "A 12mW all-digital PLL based on class-F DCO for 4G phones in 28nm CMOS," *IEEE VLSI Circ. Symp.*, 2014, pp. 1–2.