



Title	The influence of recycled asphalt pavement on the fatigue performance of asphalt concrete base courses
Authors(s)	Tabakovic, Amir, Gibney, Amanda, McNally, Ciaran, Gilchrist, M. D.
Publication date	2010-06
Publication information	Tabakovic, Amir, Amanda Gibney, Ciaran McNally, and M. D. Gilchrist. "The Influence of Recycled Asphalt Pavement on the Fatigue Performance of Asphalt Concrete Base Courses." American Society of Civil Engineers, June 2010. https://doi.org/10.1061/(ASCE)MT.1943-5533.0000093 .
Publisher	American Society of Civil Engineers
Item record/more information	http://hdl.handle.net/10197/3189
Publisher's version (DOI)	10.1061/(ASCE)MT.1943-5533.0000093

Downloaded 2026-05-02 00:24:34

The UCD community has made this article openly available. Please share how this access benefits you. Your story matters! (@ucd_oa)



© Some rights reserved. For more information

The Influence of Recycled Asphalt Pavement on the Fatigue Performance of Asphalt Concrete Base Courses

Amir Tabaković¹, Amanda Gibney^{1*}, Ciaran McNally¹, Michael D. Gilchrist²

* corresponding author; amanda.gibney@ucd.ie

¹ School of Architecture, Landscape and Civil Engineering University College Dublin, Ireland.

² School of Electrical, Electronic and Mechanical Engineering, University College Dublin, Ireland.

Abstract: This paper presents the physical properties of Recycled Asphalt Pavement (RAP) and its influence on the mechanical performance of a binder course asphalt pavement mix. A series of binder course mixes were designed containing varying percentages of RAP. A mix made from only virgin material was selected as the control mix for the investigation. The effect of introducing RAP into the binder course mix was evaluated through a series of laboratory tests including the Marshall test, the indirect tensile stiffness modulus Test, the indirect tensile fatigue test and the water sensitivity test. A Circular Wheel Track (CWT) was developed in order to study the dynamic effects of a rolling wheel travelling over an asphalt pavement. The CWT was commissioned within a temperature controlled room along with a customised data acquisition system. The system involves the testing of rectangular slabs and allows for the investigation of dynamic tensile strain. The laboratory tests have shown that the introduction of RAP to the binder course mix resulted in an improvement in all mechanical properties. In particular, it was found that the mix containing up to 30% RAP, displayed improved fatigue resistance relative to the control mix manufactured from virgin materials.

Keywords: Recycling; Asphalt Pavements; Performance characteristics.

Introduction

The last decade has seen a constant increase in asphalt production throughout Ireland and Europe (EAPA 2006), and this has been matched by increased consumption of virgin

aggregates. The need to preserve these valuable (non-renewable) natural aggregates and to reduce landfill deposition of construction and demolition (C&D) waste has encouraged the Irish road construction industry to look to C&D waste as an alternative source of aggregates (Rudden 2004). The most recent Environmental Protection Agency report (EPA 2006) revealed that RAP constituted 2% of Ireland's total C&D waste produced in 2006. RAP has the inherent potential to be reused in new hot asphalt mix production and, as such, represents an ideal alternative material for road construction. Another advantage of RAP is that if the recycling process is well managed it can be reused completely (Sherwood 2001; Gerardu & Hendriks 1985). Previous research (Karlsson and Isacsson 2006; Aravind and Das 2007), demonstrated that including RAP into bituminous mixtures is an intricate procedure, as a mixture containing RAP must perform as well as a conventional mixture. Internationally, both Europe and North American authorities have developed protocols to govern the recovery and use of RAP as a secondary aggregate (EN 13108 2005; NCHRP 2001).

European countries such as the Netherlands and the UK have developed their own RAP recycling practices (Jansen and Put 2004; Khalaf 2004; Sherwood 2001), and have introduced guidelines for the use of secondary aggregates in road construction (Collins et al 2004). In the Irish context, the National Roads Authority (NRA) noted in 2005 that RAP may be used in the production of bituminous base (NRA 2005). The maximum amount of RAP currently permitted by the NRA is 20% for a coated macadam base, which must also comply with the British Standard (BSI 2005).

Even though design standards have been developed to ensure the quality control of RAP, the Irish construction industry has failed to embrace the incorporation of RAP in new road construction projects. In 2004 only 0.2% of the total available RAP material was used in new hot mix asphalt production (EAPA 2004). It is speculated that this is due to the continued availability of high quality, low-cost virgin aggregates and a lingering perception that asphalt produced using recycled aggregate will be inferior to one using virgin material only. This research aims to challenge the perception of RAP as being inferior to natural aggregates and to demonstrate the potential role for RAP in road construction.

This paper examines the physical properties of RAP and the influence of RAP on the mechanical properties of a 20mm binder course mix. RAP was introduced into the bituminous mixtures at levels of 10%, 20% and 30%, replacing the virgin constituents in the mix (coarse and fine aggregate). Control samples (without RAP) were also manufactured.

Both the physical properties of the RAP aggregate and the mechanical material properties of the 20mm binder course mix with the inclusion of RAP were investigated using standard laboratory tests and a custom built Circular Wheel Track (CWT) test rig.

Materials

For this project the RAP material was sourced from a local stockpile intended for commercial use. The material was not analysed prior to extraction from the road and its specific origins are unknown.

The binder content of the RAP was determined following the procedure described in EN 12697: Part 39 (Irish Standards 1998). A set of four representative samples of RAP were used to determine the binder content which was found to be 1.83%.

The relative density of the RAP was also determined using the procedure described in BS 812: Part 2 (BSI 1995). Again four representative samples of RAP were used and the apparent relative density of the RAP calculated to be 2626 kg/m³.

Mix Design

The bituminous mixture investigated in this study was a 20mm binder course mix typically found in Irish practice. In order to investigate the influence of RAP on the fatigue performance of the 20mm binder course mix, varying percentages of RAP were incorporated into the mix design. RAP was introduced to the bituminous mixtures at levels of 10%, 20% and 30%. Control samples not containing RAP were also used throughout the testing.

Four representative samples were taken to determine the aggregate gradation, according to the British standard BS 812: Part 103.1 (BSI 1985). The grading results showed the RAP to be continuously graded and as such suitable to replace a proportion of each constituent in the mix.

Following BS 4987: Part 1 (BSI 2005) four mixes containing 0%, 10%, 20% and 30% RAP were designed; Fig.1 illustrates the effect of RAP on gradation, showing how the mix designs fit within the standard grading envelope specified in BS 4987: Part 1; the mix designs are given in Table 1.

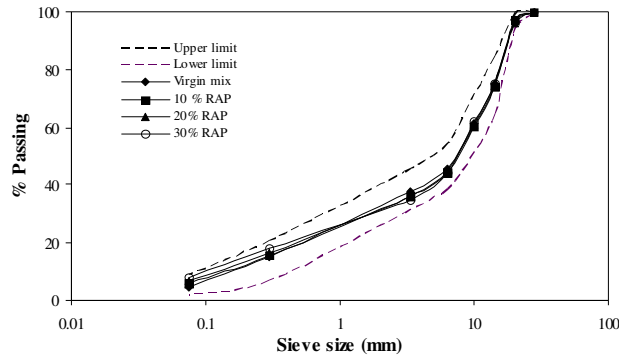

Fig. 1. Particle size distribution for mix design.

Table 1. Mix Designs

Mix No.	RAP (%)	20mm (%)	14mm (%)	10mm (%)	CRF (%)	Sand (%)
1	0	31	12	18	27	12
2	10	31	10	16	20	13
3	20	28	10	14	16	12
4	30	26	8	14	12	10

Mix Aggregate Surface Area

The mix aggregate surface area of the mixtures were calculated to establish the change in surface area resulting from the inclusion of different percentages of RAP into the mix and to identify whether any major adjustment was required to the amount of added binder content in the resulting mixes. The mix aggregate surface area of a mix aggregate was calculated via (Shell Bitumen 1991):

$$T = \frac{b}{100 - b} \times \frac{1}{D_b} \times \frac{1}{SAF} \quad (1)$$

where:

- T = bitumen film thickness (m),
- D_b = density of bitumen (kg/m^3),
- SAF = surface area factor (m^2/kg),
- b = bitumen content (%).

Table 2 summarises the mix aggregate surface area calculations. The total mix aggregate surface area of the binder course mix decreases with increased RAP content, implying a reduction in the required added binder content.

Table 2. Mix Surface Area Factor

	Mix Aggregate Surface Area (mm ² /kg)			
	0% RAP	10% RAP	20% RAP	30% RAP
Total:	6.315	6.202	6.101	5.849

Laboratory Testing

Marshall Test

In accordance with BS 598: Part 107 (BSI 2004) the Marshall test was employed in an attempt to determine the optimum binder content for the mix. A 70/100 pen bitumen was used in the mix. A series of test specimens was prepared for a range of different binder contents with the result that the test data curves show well-defined relationships. The test method was modified, in that the specimens were compacted in the gyratory compactor in accordance with test standard EN 12697-31 (Irish Standards 2007). Initially, a Marshall compaction hammer was used to compact the specimens, but preliminary results showed dispersion in the stability and flow values obtained. Subsequent, samples were compacted using the gyratory compactor: these samples demonstrated consistent stability and flow test results. Recent research also indicated less variation in sample void content and stiffness results when gyratory compaction was used, (Fitzsimons and Gibney 2004; Hartman et al 2001b). The dimensions of the test specimens were 100mm in diameter and 63.5mm in height with a void content of 6%. Four test specimens were compacted for each percentage of binder content, in total 104 specimens were tested. The Marshall test results are presented in Table 3. These results illustrate that the optimum level of added binder content for the mix decreases with each corresponding increase in the proportion of RAP. This is considered to be a function of the presence of pre-existing binder within the RAP and the calculated reduction in aggregate surface area of the mix with increased RAP content.

Table 3. Optimum Binder Content for Selected Mixes

RAP (%)	Optimum Binder Content (%)
1	4.70
10	4.20
20	4.16
30	4.00

As a result of the low binder content in the RAP (1.83%), the percentage of recovered binder within the mixtures was low; for example the mix containing 30% RAP added only 0.5% of recovered binder to the mix. The small content of aged binder in the RAP raised concerns that a reduction in the added binder content could compromise the durability of the mix. This was discussed with industrial partners who felt that the road construction industry would be reluctant to use a mix with an added binder content of below 4.5%. While the design binder content calculations presented in Table 3 suggested the feasibility of reducing the added binder content with the introduction of RAP into the mix, the decision was taken to accept the advice of the industrial partners and to use an added binder content of 4.5% for all mixtures tested.

Stiffness Modulus Test (ITSM)

Alongside the Marshall load test, a non-destructive ITSM test was conducted which complied with BS DD 213 (BSI 1993). Four test specimens were tested for each percentage of binder content. The results are illustrated in Fig. 2, which show increased stiffness values with increasing content of RAP in the mix; the peak stiffness was observed at a mix binder content of between 2.5 and 3.0%. The stiffness value of all the mixes are very close at the chosen mix binder content of 4.5% and range from 3.8 to 4.1GPa, as illustrated in Fig. 2.

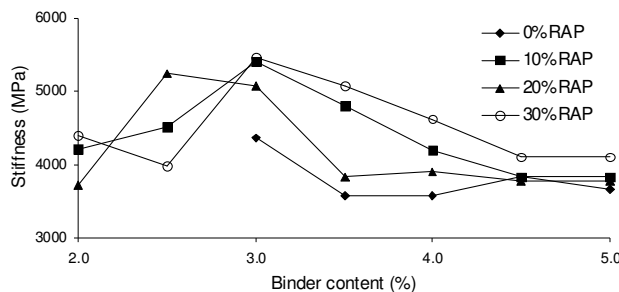

Fig. 2. Influence of binder content on stiffness modulus for varying RAP contents

Water Sensitivity Test

The moisture sensitivity test was performed in accordance with EN 12697-12 (2003). For each mix, six specimens, 100mm diameter and 70mm in height with a void content of 6%, were prepared using the gyratory compactor. An Instron servo-hydraulic system was

employed to determine the indirect tensile strength test (ITS) in accordance with EN 12697-23 (Irish Standards 1998); the results are presented in Table 4.

Guidance values given for the moisture sensitivity test suggest that ratios of wet to dry indirect tensile strengths of less than 80% indicate moisture damage, (Solaimanian and Harrigan 2002). From the results presented in Table 4 it is evident that moisture damage is not an issue for the mixes containing 0%, 10% and 20% RAP. With the inclusion of 30% of RAP in the mix, the ITS ratio decreases to below 90%, suggesting that further increases in RAP content could leave the mix vulnerable to moisture damage.

Table 4. Moisture Sensitivity Test Results

RAP (%)	ITS wet (MPa)	ITS dry (MPa)	ITS Ratio (%)
0	0.92	0.97	93
10	0.92	0.90	102
20	0.87	0.93	94
30	0.81	0.93	88

Indirect Tensile Fatigue Test

The indirect tensile fatigue test (ITFT) was carried out according to the procedure described by BS DD ABF (BSI 1997). Nine specimens were manufactured for each mix, each specimen being 100mm in diameter and 70mm in height with a void content of 6%. These were again prepared using a gyratory compactor. The specimens were subjected to a repeated constant load with 124ms ± 4ms loading time and pulse repetition time of 1.5 ± 0.1second at a temperature of 20°C. Prior to the ITFT test, the indirect tensile stiffness modulus parameter was obtained for the specimens at the fatigue test stress level.

The results of these tests are presented in Fig. 3. Ullidtz (1998) developed a relationship between maximum tensile strain and the fatigue life of the material, (2) below.

$$N = k_1 \varepsilon^{-k_2} \quad (2)$$

where:

- N = number of load cycles to failure,
- ε = maximum tensile strain,
- k₁, k₂ = material coefficients

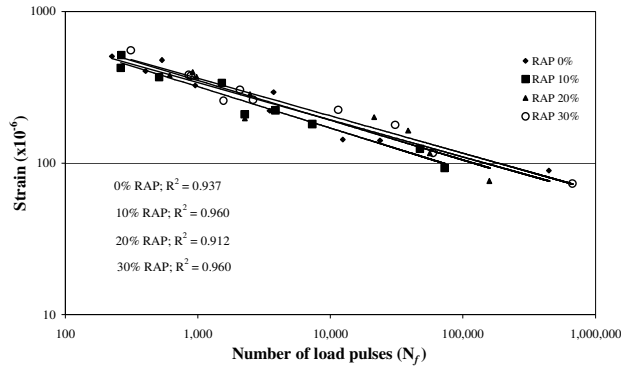

Fig. 3. Effect of RAP content on the tensile strain response under repetitive pulse loads.

This relation is applied to the results in Fig. 3 and a regression analysis is carried out, the results of which are presented in Table 5. It is apparent from this analysis that the mix with 10% RAP demonstrated the lowest resistance to fatigue, whereas that with 30% RAP performed significantly better than all other mixes. This is in good agreement with the findings of Shu et al (2008). Using beam fatigue tests they also found similar fatigue behaviour at RAP contents of up to 20%, but an improved performance when 30% RAP was used.

Table 5. Results of Fatigue Life Regression Analysis

RAP (%)	Coefficients		R^2	Cycles at 100
	k_1 ($\times 10^{-12}$)	k_2		
0	5.0	-3.82	0.94	112,750
10	0.7	-3.50	0.96	70,000
20	1.7	-3.60	0.91	109,800
30	100	-3.89	0.96	167,800

Circular Wheel Track

To study the dynamic effects of a rolling wheel travelling over an asphalt pavement and in order to better understand the initiation and growth of fatigue cracks, a Circular Wheel Track (CWT) test was developed, based on a study previously carried out by Hartman et al (2001a). A schematic diagram of the CWT is shown in Fig. 4.

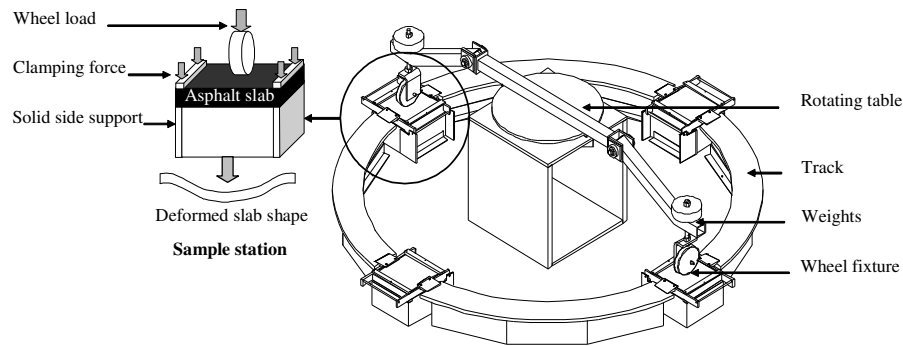

Fig. 4. Schematic diagram of the Circular Wheel Track (Hartman et al., 2001a).

The testing facility permitted large slab specimens (305x305x50mm) to be tested using dynamic wheel loading. The slab specimens were supported on a soft elastomeric foundation, which represented a weak foundation and also prevented gravitational bending of the slabs. The CWT was housed in a temperature controlled room and a data acquisition system was also developed to measure the dynamic strain at the bottom of the test slabs. Using this system, all four mixtures were evaluated under identical loading and temperature conditions, i.e. at a temperature of 20°C and with a vertical constant loading of 80kg per wheel, which resulted in a tyre pressure of approximately 695kPa per wheel. The diameter of the working circle is 3m, and the large arc of the track reduces the effect of cornering on the specimen; centrifugal forces are minimised by the relatively slow operational speed of the CWT, of approximately 3km/h (or 7rpm).

Crack Propagation Test

Four test specimens were manufactured for each RAP content, giving 16 specimens in total. These were compacted using the standard Cooper Research Technology Roller Compactor. After compaction, the specimens were left to cure for 24 hours at approximately 20°C (room temperature). Prior to testing, the bases of the test specimens were painted white, in order to facilitate the study of crack propagation, (Hartman and Gilchrist 2004). A 100x100mm square area was marked underneath the wheel path in the centre of each slab and all crack monitoring was concentrated in this area. The fatigue damage (cracks) that occurred during tests were monitored using two image capturing methods, digital photography and hand traced images, which were later digitised. At certain intervals, each test was paused, the specimens were turned and the damage recorded. Digital images were captured by a digital

camera, a transparent sheet was then placed over the monitoring area and the cracks traced manually.

The digital images were imported into digital imaging software for further image processing. The monitoring area was cropped from the original image and the image converted to greyscale. The dimensions of the monitoring area were calibrated against pixel size in order to maintain the direct dimensional measurements (100x100mm or 283x283 pixels) and a binary format (consisting only of black and white pixels) was applied to the best threshold value, as illustrated in Fig. 5.

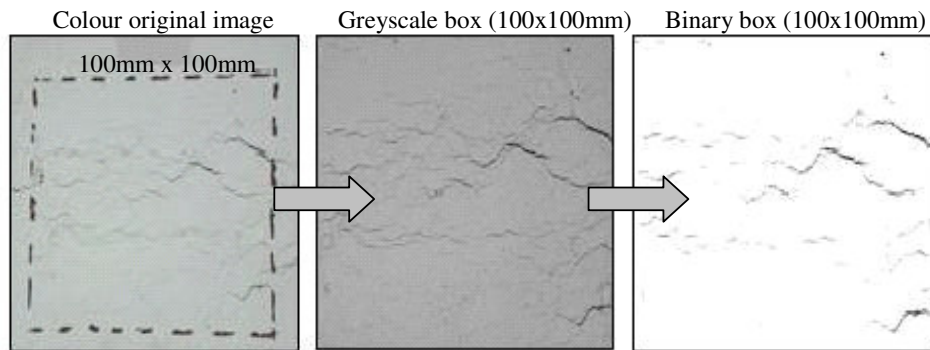

Fig. 5. Manipulation of the original image to obtain a binary image for crack analysis

A Matlab program was developed to calculate the resulting crack area. The program measured the number of black and white pixels and analysis of this data allowed the crack area to be given in mm^2 , as shown in Fig. 6. The images obtained from the manually traced transparencies were used to determine crack length, and visible defects were recorded with a marker of uniform width. Subsequent analysis involved analysing the images for crack length. For this analysis, images were imported into UTHSCSA Image Tool (2005). This method involved using an algorithm that reduces a crack to a single pixel width. The number of pixels thus related directly to a physical crack length and is also represented in Fig. 6. This process did lead to some variation in the results, particularly with respect to crack area. In these cases the Q-test with a 90% confidence limit was used to identify outliers, leading to significantly less variation in the reported results.

As the slabs were clamped parallel to the direction of wheel travel, it allowed the test specimens to bend in the same direction as the wheel travel and as a result, the cracking primarily occurred in the direction of the wheel travel. Fig. 6 illustrates that the crack length increases sharply initially, and then after some 1000 passes, increases more gradually. The

crack area can be seen to have gradually increased as the test progressed. The measurements of crack length and crack area at the bottom of the slab successfully characterised the first stage of initial crack formation.

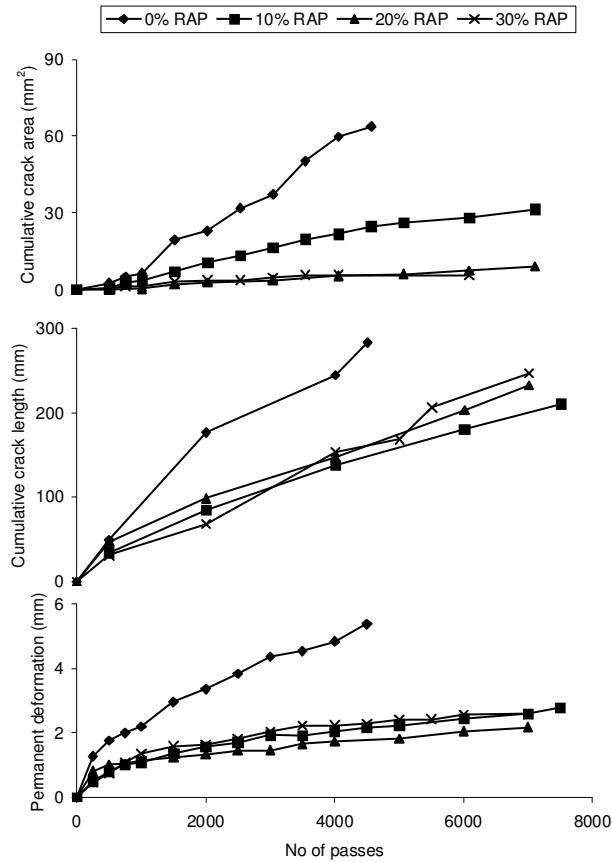

Fig. 6. Crack area measurements, cumulative crack length and permanent central deflection

Permanent Deflection Test

The development of permanent central deflection as the test progress is also highlighted in Fig. 6. The initial high rate of deformation was considered to be due to the soft elastomeric foundation directly beneath the slab (as illustrated in Fig. 4). When the slab is loaded, it is forced to reposition i.e. to bend slightly, causing a small sharp deformation in the initial phase of the test. As the wheel tracking continued, the effect of this initial “bedding-in” of the test specimen in the apparatus reduced, the rate of deformation was less, as evidenced by the results presented in Fig. 6. This also indicates increased resistance to permanent deformation with the inclusion of RAP. It is observed that the control mix (0% RAP) exhibited

more viscous behaviour (large flow) than the mixtures containing RAP, and therefore experienced larger deformations. This was unexpected given that the mixtures containing RAP had a higher total content of bitumen in the mix (both fresh and aged). These results however are in agreement with those published by Pereira et al (2004) who using a repeated simple shear test, found that resistance to permanent deformation increased with RAP content.

Peak Strain Response

The CWT was designed primarily to measure peak strain at the base of test specimens. In order to monitor the peak strain, a DAQ system was developed using LabView software to collect data from the strain gauges, placed on the underside of the slab specimens, as shown in Fig. 7. Longitude and transverse strain was measured using electrical resistance strain gauges attached to the specimen via a thin brass strip. This was done in order to eliminate any local aggregate effects on the strain gauges; brass was used as its stiffness is similar to that of a bituminous mixture. This system was previously developed by Hartman et al (2001a).

During tests the peak transverse and longitudinal tensile strains were monitored and the total transverse and longitudinal strain calculated. When a test sample reached a permanent deflection limit of 5 mm, it was removed from the test rig.

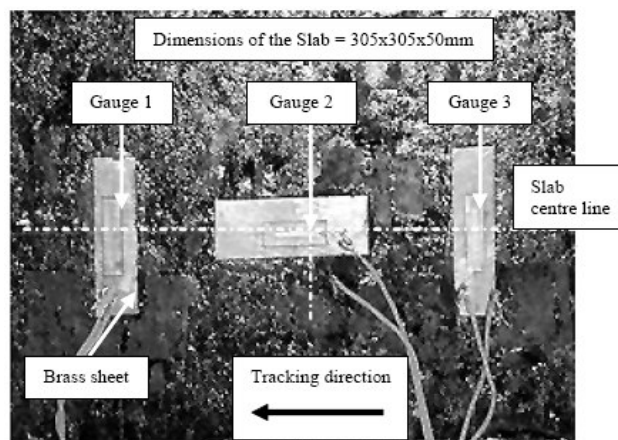

Fig. 7. Position of strain gauges on underside of test specimen.

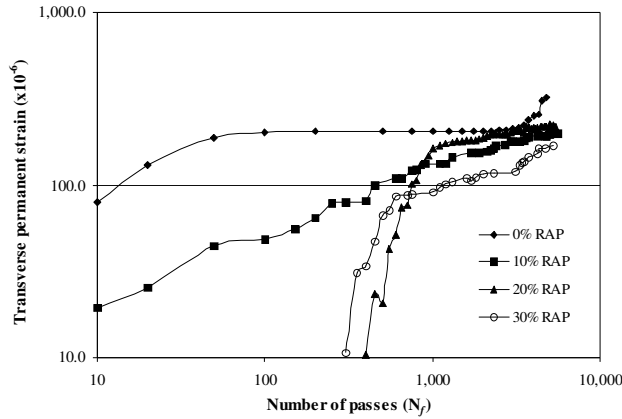

Fig. 8. Development of transverse dynamic tensile strain under fatigue loading.

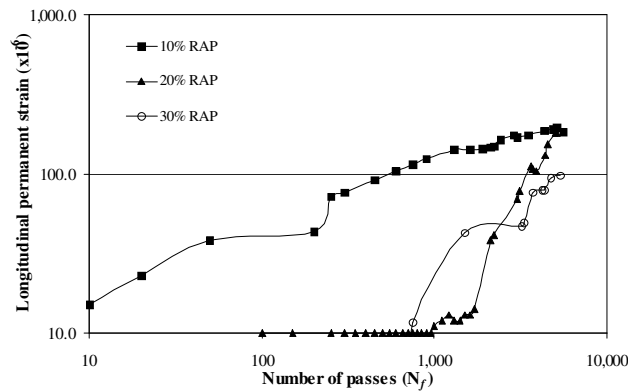

Fig. 9. Development of longitudinal dynamic tensile strain under fatigue loading

Fig. 8 and 9 illustrate the typical manner in which the transverse and longitudinal dynamic strains varied during loading intervals for all binder course mixes. From the transverse strain results, in Fig. 8, it can be observed that initially the strains for the mixtures containing 20% and 30% RAP demonstrate good resistance to dynamic loading up to 500 wheel passes. Beyond 500 passes, the strain sharply increased up until some 1000 passes, after which it settled and followed patterns similar to those observed in the first strain test. The test illustrated gradual improvement in wheel-tracking strength with increased RAP content in the mix. All mixtures containing RAP outperformed the control virgin mix (0% RAP). However, the samples did all display a similar final strain level. The mixture containing 30% RAP demonstrated the best fatigue wheel-tracking strength of all four mixtures.

Similar results were observed when longitudinal permanent strain was monitored. Once more permanent strain developed quite quickly in the samples with low RAP content;

this is not the case for samples with 20 and 30% RAP where initial strains remained quite low until 1000 wheel passes. As was the case for transverse strain however, the final permanent longitudinal strain values observed were relatively similar regardless of RAP content. The results for the test with 0% RAP were rejected due to a localised failure adjacent to the strain gauge location. It is proposed that the strain gauge configuration could be improved by replacing the existing system with that used by Jooste et al. (1999), where a synthetic base was placed on the underside of the asphalt slab and three strain gauges, measuring transverse and longitudinal strain, were placed underneath the synthetic base. The size of the sheet would prevent any aggregate influence on the strain gauges.

A clear trend can be seen across the results shown in Figures 6, 8 and 9, namely a significant initial response from the asphalt materials at the start of the test (i.e. the first 500 – 1000 wheel passes). A similar pattern was observed by Hartman et al (2001a) who noted that this rapid initial increase of strain, crack length and permanent deformation typically represented 30% of the fatigue life of the specimen. At this initial stage of the test it was observed that a large number of small individual cracks opened, and as the test progressed, began to interconnect forming a crack network. Once a full-width crack was formed, it then propagated throughout the depth of the slab. Thus the first two modes of crack propagation could be distinguished: first a crack initiation stage, during which a network of cracks is formed resulting sharp increase in crack length, permanent deflection and strain. This is followed by the crack propagation stage, during which cracks have gradually propagated through the depth of the slab, expanding in width and resulting in a gradual increase in crack length, strain and permanent deformation. The third stage of fatigue was not observed as the test was halted after a permanent deformation of 5 mm due to concerns for the safety of the testing facility.

Conclusions

A series of binder course mixtures incorporating RAP were tested and demonstrated improved mechanical properties relative to the control mix. For example the mixture containing 30% RAP and 4.5% binder displayed a 7% increase in stiffness, a 90% reduction in crack area and a 33% increase in number of cycles to failure in the Indirect Tensile Fatigue Test when compared to the control mix.

The mechanical test results demonstrated that RAP can be used as a viable alternative aggregate material for a 20mm binder course mixture. The laboratory tests demonstrated that the binder course mixtures containing 30% RAP out-performed the control mix when subjected to fatigue loading. However care must be taken with respect to the water sensitivity of the mix. The tests showed that the ITR dropped to 94% for 20% RAP and 88% for 30% RAP respectively. While this is still above the critical threshold of 75%, the downward trend is a cause for concern. This study demonstrated that the water sensitivity test could be used as a suitable regulatory test for RAP inclusion in the hot-mix asphalt mix, offering a measure of mix durability.

Although the crack test and permanent tensile strain test results did illustrate some discrepancies, the 20mm binder course mixtures containing RAP demonstrated a performance at least equal to that of the control mix manufactured without RAP. The wheel-tracking tests also demonstrated that the inclusion of 30% RAP into the mix improved the mix fatigue performance.

Acknowledgements

The authors wish to thank: Mr. Tom Webster, University College Dublin for his assistance with the laboratory testing, Enterprise Ireland (ATRP\02\413) for provided funding for this research, Roadstone Dublin Ltd. for supplying raw materials, Shell Bitumen Ireland for supplying the bitumen and Dr. Anton Hartman, Africon Engineering International for providing advice during the CWT test design.

References

- Aravind, K. and Das, A. (2007). "Pavement design with central plant hot-mix recycled asphalt mixes", *Constr. Build. Mater.* 21(5), pp. 928-936.
- BSI. (1985). *BS 812: Part 103.1. Testing aggregates. Method for determination of particle size distribution – sieve test*, British Standard Institution, London, UK.
- BSI. (1993). *DD 213. Method for determination of the indirect tensile stiffness modulus of bituminous mixtures*, British Standard Institution, London, UK.
- BSI. (1995). *BS 812: Part 2. Testing aggregates. Method for determination of density*, British Standard Institution, London, UK.

- BSI. (1997). *DD ABF. Method for determination of the fatigue characteristics of bituminous mixtures using indirect tensile fatigue*, British Standard Institution, London, UK.
- BSI. (1999). *DD 250. Test methods for the analysis of bituminous mixtures by ignition*, British Standard Institution, London, UK.
- BSI. (2004). *BS 598: Part 107. Sampling and examination of bituminous mixtures for roads and other paved areas. Method of test for the determination of the composition of design surface course rolled asphalt*, British Standard Institution, London, UK.
- BSI. (2005). *BS 4987: Part 1. Coated macadam for roads and other paved areas. Specification for constituent materials and mixtures*, British Standard Institution, London, UK.
- Collins, R.J., Dunster, A. and Kennedy, J. (2004). *Improving Specifications for the Use of Recycled and Secondary Aggregates in Construction*. WRAP, Oxon, UK, ISBN 1844052060.
- Environmental Protection Agency (EPA). (2006). *National Waste Report*. Environmental Protection Agency, Dublin, ISBN 1840952628.
- European Asphalt Pavement Association (EAPA). (2006). *Asphalt in Figures 2006*. European Asphalt Pavement Association, available for download at www.eapa.org
- Fitzsimons L. & Gibney A. (2004). "Recycled glass in hot rolled asphalt wearing course mix", Proc. Int. Conf. on Sustainable Waste Management and Recycling: Challenges and Opportunities, Lambachiya, M.C. & Roberts, J.J. eds, ISBN 0727732846, London, UK, pp. 187-196.
- Gerardu, J.J.A. and Hendriks, C.F. (1985). "Recycling of road pavement materials in the Netherlands", *Rijkswaterstaat Communications No. 38*, The Hague.
- Hartman, A.M. and Gilchrist, M.D. (2004). "Evaluating four-point bend fatigue of asphalt mix using image analysis", *ASCE J. Mater. Civ. Eng.*, 16(1), pp. 60–68.
- Hartman, A.M., Gilchrist, M.D. and Nolan, D. (2001a). "Wheel-tracking fatigue simulation of bituminous mixtures", *Int. J. of Road Mater. Pavement*, 2(2), pp. 141-160.
- Hartman, A.M., Gilchrist, M.D. and Walsh G. (2001b). "Effect of mixture compaction on indirect tensile stiffness and fatigue", *ASCE J. Transp. Eng.* 127(5), pp. 370-378.
- Irish Standards. (2005). *IS EN 12697: Part 42. Bituminous mixtures. Test methods for hot mix asphalt. Amount of coarse foreign matter in reclaimed asphalt*, Dublin, Ireland.
- Irish Standards. (2005). *IS EN 13108: Part 8. Bituminous mixtures. Material specifications. Reclaimed asphalt*. Dublin, Ireland.

- Irish Standards. (2004). *IS EN 12697: Part 24. Bituminous mixtures. Test methods for hot mix asphalt. Resistance to fatigue*. Dublin, Ireland.
- Irish Standards. (2004). *IS EN 12697: Part 26. Bituminous mixtures. Test methods for hot mix asphalt. Stiffness*. Dublin, Ireland.
- Irish Standards. (2003). *IS EN 12697: Part 12. Bituminous mixtures. Test methods for hot mix asphalt. Determination of the water sensitivity of bituminous specimens*. Dublin, Ireland.
- Irish Standards. (1998). *IS EN 12697: Part 39. Bituminous mixtures. Test methods for hot mix asphalt. Binder content by ignition*. Dublin, Ireland.
- Irish Standards. (2007). *IS EN 12697: Part 31. Bituminous mixtures. Test methods for hot mix asphalt. Specimen preparation by gyratory compactor*. Dublin, Ireland.
- Irish Standards. (1998). *IS EN 12697: Part 23. Bituminous mixtures. Test methods for hot mix asphalt. Determination of the indirect tensile strength of bituminous specimens*. Dublin, Ireland.
- Jansen, G.M.T. and Put, J. (2004). "Use of recycled materials in construction", *Proc. Int. Workshop on Recycled Material in Pavement Design*, McNally, C., Gibney, A. and Gilchrist, M.D. eds. University College Dublin, ISBN: 954694007, pp. 43-48.
- Jooste, F., Verhaeghe, B. and Crawford, A. (1999). "Asphalt strain response under moving wheel loads", *Proc. 7th Conf. Asphalt Pavements for Southern Africa*, Victoria Falls, Zimbabwe.
- Karlsson, R and Isacson, U. (2006). Material related aspects of asphalt recycling state of the art", *ASCE J. Mater. Civ. Eng.*, 18(1), pp. 81-92.
- Khalaf, F.M. (2004). "Recycling of clay bricks as aggregate in asphalt concrete", *Proc. Int. RILEM Conf. Use of Recycled Materials in Buildings and Structures*, Vázquez, E., Hendriks, Ch. F. and Janssen, G.M.T. eds. Barcelona, Spain, ISBN 2912143523, pp. 56–65.
- National Roads Authority (NRA). (2005). *Manual of Contract Documents for Road Works, Series 900*, National Roads Authority, Dublin.
- National Cooperative Highway Research Program (NCHRP). (2001). *Recommended Use of Reclaimed Asphalt Pavement in the Superpave Mix Design Method: Guidelines*. Research Results Digest No. 253, Transport Research Board, National Research Council, Washington, DC.

- Pereira, P.A.A., Oliveira, J.R.M., Picado-Santos, L.G. (2004). "Mechanical characterisation of hot mix recycled materials", *Int. J. Pavement Eng.*, 5(4), pp. 211-220.
- Rudden, P.J. (2004). "Construction and demolition waste recycling-part of national waste strategy", *Proc. Int. Workshop on Recycled Material in Pavement Design*, McNally, C., Gibney, A. and Gilchrist, M.D. eds. University College Dublin, ISBN: 954694007, pp. 1-16.
- Shell Bitumen. (1991). *The Shell Bitumen Handbook*. Shell Bitumen U.K., ISBN 0951662503.
- Sherwood, P.T. (2001). *Alternative materials in road construction*. 2nd Edition, Thomas Telford, ISBN 0727730312.
- Shu, X., Huang, B. and Vukosavljevic, D. (2008). "Laboratory evaluation of fatigue characteristics of recycled asphalt mixture", *Constr. Build. Mater.* 22(7), pp. 1323-1330.
- Solaimanian, M. and Harrigan, E. (2002). "Improved conditioning procedure for predicting the moisture susceptibility of HMA pavements", *Proc. Moisture Damage Symposium*, Laramie, Wyoming, USA.
- UTHSCSA (2005). *Image tool version 3.00*. University of Texas Health Science Center Department of Dental Diagnostic Science, San Antonio, Texas, USA.