



Title	Structural health monitoring of reinforced concrete beam using piezoelectric energy harvesting system
Authors(s)	Cahill, Paul, O'Keeffe, Rosemary, Jackson, Nathan, Mathewson, Alan, Pakrashi, Vikram
Publication date	2014-07-11
Publication information	Cahill, Paul, Rosemary O'Keeffe, Nathan Jackson, Alan Mathewson, and Vikram Pakrashi. "Structural Health Monitoring of Reinforced Concrete Beam Using Piezoelectric Energy Harvesting System." INRIA Rennes - Bretagne Atlantique, July 11, 2014.
Conference details	EWSHM 2014: 7th European Workshop on Structural Health Monitoring, IFFSTTAR, Inria, Université de Nantes, Nantes, France, 8-11 July 2014
Publisher	INRIA Rennes - Bretagne Atlantique
Item record/more information	http://hdl.handle.net/10197/10899

Downloaded 2026-04-30 03:05:59

The UCD community has made this article openly available. Please share how this access benefits you. Your story matters! (@ucd_oa)



© Some rights reserved. For more information

STRUCTURAL HEALTH MONITORING OF REINFORCED CONCRETE BEAM USING PIEZOELECTRIC ENERGY HARVESTING SYSTEM

Paul Cahill¹, Rosemary O’Keeffe², Nathan Jackson², Alan Mathewson², Vikram Pakrashi¹

¹ *Dynamical Systems & Risk Laboratory, School of Engineering, University College Cork, College Road, Cork, Ireland.*

² *Heterogeneous Systems Integration Group, Microsystems Group, Tyndall National Institute, University College Cork, Ireland.*

p.a.cahill@umail.ucc.ie

ABSTRACT

There has been focus in recent times in the creation of smart, wireless sensor networks for the purposes of Structural Health Monitoring of large scale civil infrastructure. However, the power requirements of such networks are dependent on finite batteries, which limit the effectiveness of such a system. The use of energy harvesters, however, offers a viable and attractive solution to this problem. This paper investigates the use of such energy harvesters not only to power wireless sensor nodes, but to also act in the process as a damage detection tool. The properties and creation of such energy harvesters is detailed in full. The effects of damage on a simply supported reinforced concrete beam are investigated through finite element analysis. The use of the energy harvesters for damage detection is subsequently investigated and the feasibility of using such harvesters is experimentally validated. The simultaneous power of wireless sensor nodes by the harvesters is determined and an energy harvesting circuit is examined in this regard. This paper establishes the basis and viability of using an energy harvesting system for use in this dual role.

KEYWORDS : *Structural Health Monitoring, Energy Harvesting, Experimental Analysis, Finite Element Analysis.*

INTRODUCTION

The field of structural health monitoring for civil infrastructure elements is in a state of constant evolution. Novel methods for the detection of damage are regularly being proposed, as well as variations and improvements to existing approaches. Much work has taken place into the use of vibration based monitoring through analysis of a system and the use of non-destructive sensing [1]. Numerous methods on damage detection have been proposed and utilised, including the use of wavelet analysis [2] and surface based texture analysis [3], amongst many other methods. The use data obtained from bridge vehicle interaction for structural health monitoring has received significant investigation [4, 5], including methods to detect the evolution of the damage [6]. Recent focus has been turned to the use of wireless sensor networks for the structural health monitoring of civil infrastructure [7], however the finite lifetime of batteries currently makes the wide scale use of these systems impractical. There is therefore a need for a wireless sensor network for structural health monitoring whose power requirements are completely independent of external influences. The use of energy harvesting technology to power wireless sensor nodes is a solution for negating the requirement of external power supplies. Through the use of electromechanical, piezoelectric and electromagnetic energy harvesters, ambient vibrational energy from a host can be converted into electrical energy [8]. The use of such harvesters for utilising ambient vibrational energy from hot civil infrastructure has recently been investigated, especially from bridge-vehicle interaction [9, 10]. The use of such energy harvesters for structural health monitoring has also been investigated [11],

with a dual purpose of energy harvesting and structural health monitoring for train-bridge interaction being purposed [12]. Through the use of a rectifying circuit, the energy which is harvested can be stored and utilised for powering wireless sensor nodes [13]. Furthermore, the amount of energy which may be harvested can be used as an indication of the presence and magnitude of damage, with a shift in the energy harvested indicating a change in the strain conditions of the host structure due to damage. The use of an array of such harvesters can furthermore be used to detect the position of damage on the structure thus satisfying three of the four steps required for Structural Health Monitoring [14].

This paper investigates the use of energy harvesters for the purposes of structural health monitoring and powering of wireless sensor nodes. In this regard, different energy harvesting methods are investigated and an energy harvester is created. The application of such to a reinforced concrete beam is investigated and its ability to detect damage is determined through finite element and experimental analysis. The powering of a wireless sensor node utilising the harvested energy is investigated, with an investigation into a storage circuit conducted. This paper establishes the viability of the creation of inexpensive, robust energy harvesters for structural health monitoring and powering of wireless sensor nodes.

1 ENERGY HARVESTING DEVICES

Of the three different energy harvesting technologies, it was decided to utilise piezoelectric materials to form the basis of the energy harvesting devices. The reason of this is that the materials can be attached either as a cantilever based harvester or as an adhesive patched directly to the host structure. Any change in the strain conditions within and on the surface of the structure due to the presence of damage will be detected through a shift in the voltage, and subsequently the power, output, be it instantaneous or over a prolonged period of time. Thus it can operate as both a power source for a wireless sensor node utilising the harvested energy and a structural health monitoring system through any shift in the voltage output.

It was decided for the purposes of this investigation to utilise the piezoelectric material PolyVinylidene Fluoride (PVDF). PVDF is a polymer and has mechanical strength while retaining excellent flexibility. It is very non-reactive with the major of common chemicals and materials and has a very low moisture absorption rate, of less than 0.02%. This makes it an ideal candidate for use as an energy harvester which is to be bonded to the surface of a concrete host structure. The drawback to PVDF is that it exhibits lower piezoelectric properties than some of its ceramic based piezoelectric counterparts, such as Lead Zirconate Titanate (PZT). This results in a lower voltage output from PVDF for similar strain conditions when compared to PZT. The PVDF Energy Harvesters consist of PVDF film and silver electrodes on the upper and lower surface of the film [Figure 1]. Table 1 shows the physical and piezoelectric properties of the PVDF used for the creation of the energy harvesting devices.

Table 1: Physical and Piezoelectric Properties of PVDF Energy Harvesters.

Property	Symbols	Value	Unit
Piezoelectric Strain Constant	d_{31}	22	pC/N
Dielectric Permittivity	ϵ	106	pF/m
Density	ρ	1780	Kg/m³
Young's Modulus	E	8.3	GPa
Material Thickness	t	52	μm
Poisson's Ratio	ν	0.18	



Figure 1. Image of PVDF Energy Harvester

2 FINITE ELEMENT ANALYSIS AND EXPERIMENTAL TEST SETUP

For the purposes of this investigation into damage detection of a reinforced concrete beam using an energy harvesting system, a finite element analysis and an experimental investigation were conducted. A concrete beam with a single strand of 12mm steel reinforcement through the centre was chosen, with dimensions of 0.15 m and 0.065 m depth and width respectively and an effective length of 1.8m. The energy harvesting system was bonded on the underside surface of the beam and an impact load applied to the upper face. The effects of damage, introduced in the form of an open crack, on the natural frequency were investigated. The following sections outline the finite element analysis and the experimental setup, including the addition of the energy harvesting system to the beam.

2.1 Finite Element Analysis

A three dimensional finite model of the beam was constructed using the Strand7 Finite Element Analysis System. 20 node brick elements were used to construct the model, with the dimensions as outlined previously and the single strand of reinforcement through the centre of the concrete beam modelled [Figure 2]. The natural frequency of the beam was obtained, and was found to be 73.10 Hz for the undamaged case. Damage was introduced into the model in the form of an open crack centred about the midspan of the beam. A Crack Depth Ratio (CDR) of 0.05, representing a crack of 7.5 mm, was modelled and the natural frequency was found to have reduced by .15 Hz from the undamaged model, to a value of 72.95 Hz. A CDR of 0.10 was subsequently investigated, and the frequency was found to have shifted 0.54 Hz from the undamaged case, to 72.56 Hz. The natural frequency of each case is outlined in Table 2. Of note is the width of the crack introduced, of the order of 2.5 mm for each case, which is small in relation to the span of the beam.

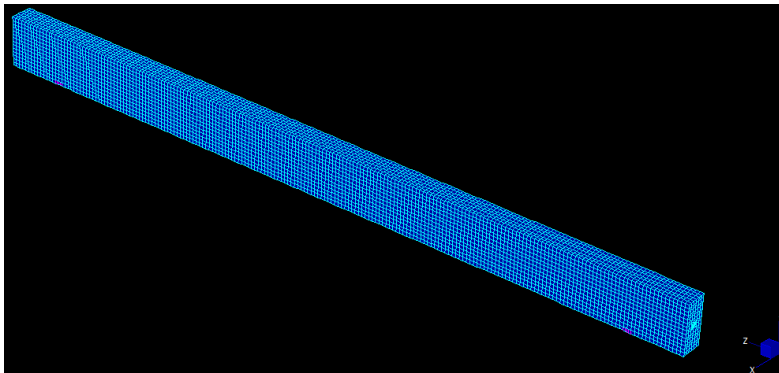

Figure 2. Finite Element Model Beam

Table 2: Natural Frequency of Finite Element Model with Increasing CDR.

Crack Depth Ratio	0.00	0.05	0.10
Natural Frequency (Hz)	73.10	72.95	72.56

2.2 Experimental Test Setup

The ability of the energy harvester to detect damage was subsequently investigated experimentally. The energy harvesting device, previously outlined in Section 1, was bonded to the underside of a reinforced concrete beam, of dimensions outlined previously. This was completed using an epoxy bonding agent. The harvester was centred about a location 83 mm from the left hand side of the beam [Figure 3.]. An impact force was applied to the upper surface of the beam and the output voltage from the energy harvester was recorded.

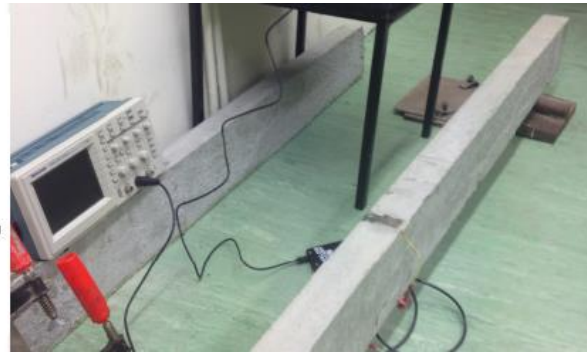
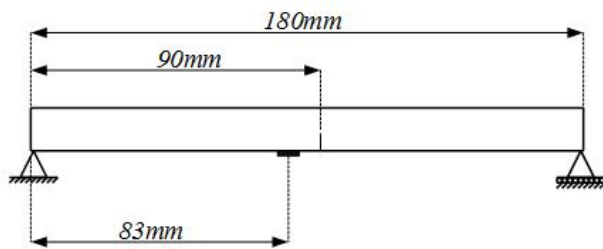

Figure 3. (a) Position of Energy Harvester and Damage Location (b) Experimental Setup

Damage was subsequently introduced to the centre span of the beam. The magnitude of the damage was similar to that of the finite element model, with a CDR of 0.05 (7.5 mm) being introduced followed by a CDR of 0.10 (15 mm) [Figure 4.]. For the damage cases, an impact forcing factor was applied to the beam and the output voltages recorded. These voltage outputs were subsequently analysed and the potential for damage detection investigated.

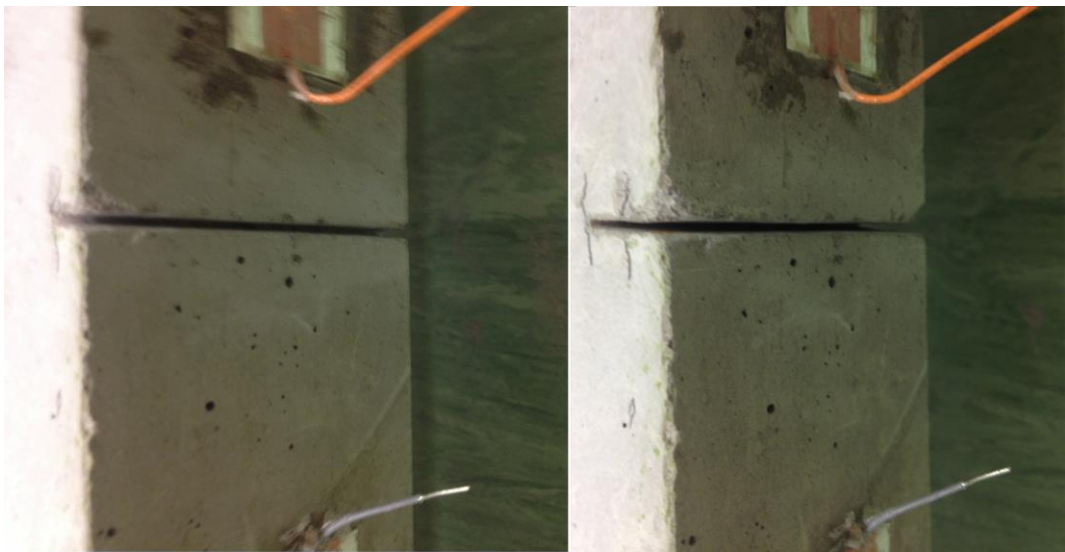

Figure 4. (a) CDR = 0.05

(b) CDR = 0.10

3 RESULTS

The output voltage obtained from the energy harvester attached to the beam was subsequently analysed to determine its ability to detect the presence of localised damage, in the form of a thin open crack. It was found that upon transferring the data into the frequency domain, the natural frequency decreased with increasing CDR [Figure 5.]. A natural frequency of 74.32 Hz was determined for the undamaged beam, 72.62 Hz for a CDR of 0.05 and 71.33 Hz for a CDR of 0.10 [Table 3.]. This shift in the natural frequency was more substantial than was predicted from the finite element model of the beam as the reduction of the stiffness is much larger in the experimental analysis. The finite element analysis is based on linear, elastic and homogeneous properties, however when cutting occurs the redistribution is difficult to predict. The ability of the energy harvester to detect damage indicates its ability to act as a structural health monitor. Under similar loading conditions, with increasing CDR the voltage output of the harvester will increase and the order of this increase will be related to the distance the energy harvester is located from the damage. Energy harvesters closer to the damage will experience a greater change in voltage output than those at a larger distance. Thus, through the use of an array of energy harvesters, the presence, location and magnitude of the damage may be determined.

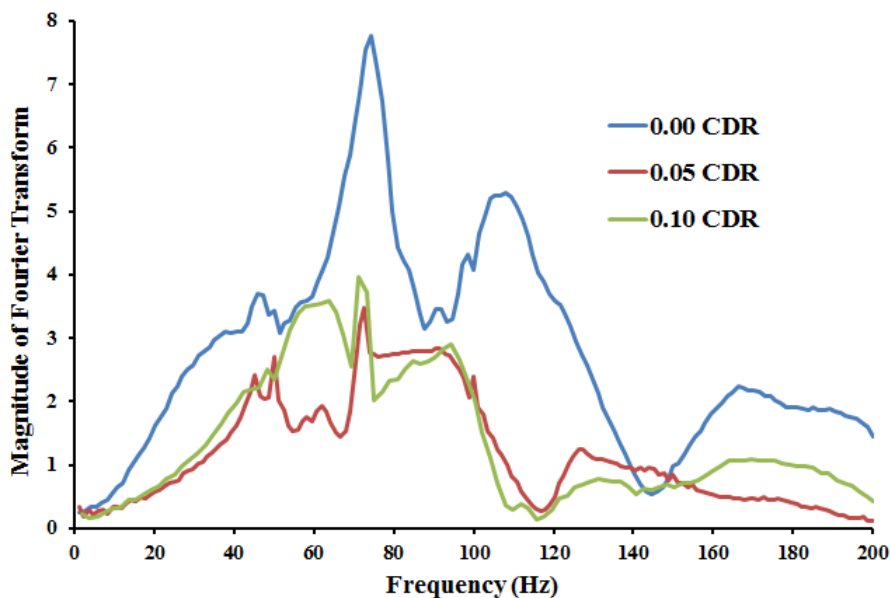

Figure 5. Frequency Domain Response of Energy Harvester for Varying CDR

Table 3: Experimental Natural Frequency of Reinforced Concrete with Increasing CDR.

Crack Depth Ratio	0.00	0.05	0.10
Natural Frequency (Hz)	74.32	72.62	71.33

4 ENERGY HARVESTING CIRCUIT

For the energy harvester to be utilised as a power supply for a wireless sensor node, it must be connected with a storage circuit. This requires firstly that the AC voltage which is generated by the energy harvester be converted into a DC voltage, which then can be stored. With the addition of a capacitor or battery as the storage unit, the power may then be utilised for a wireless sensor node once a predetermined level, dependent on the power requirements of the node, is reached. With advances in circuits, it is now possible to increase the DC voltage as the AC is being rectified. For

the purposes of this investigation, a voltage multiplier circuit was created [Figure 6.], based on the circuit proposed by Torah et al. [15].

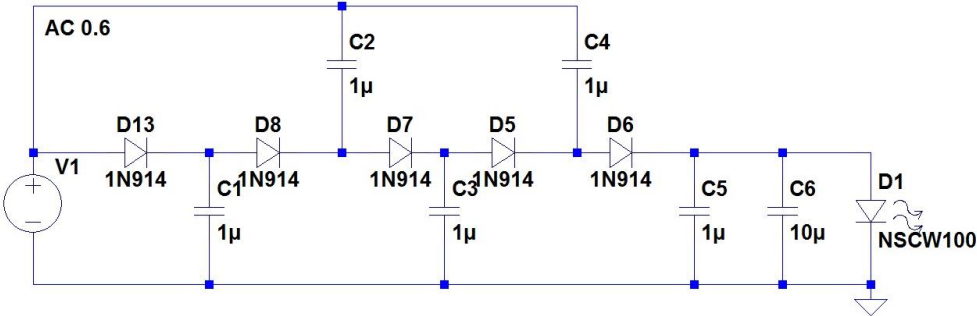

Figure 6. Voltage Multiplier Energy Harvesting Circuit.

A number of different AC voltages were investigated to determine the amount of DC voltage which can be utilised for storage and thus, powering of wireless sensor nodes. It was found for that for all voltages investigated; ranging from 0.5V to 2V, the respective DC voltage outputs had increased due to the multiplier circuit [Figure 7.]. This circuit lends itself towards energy harvesting from large scale civil infrastructure when combined with the energy harvesting devices.

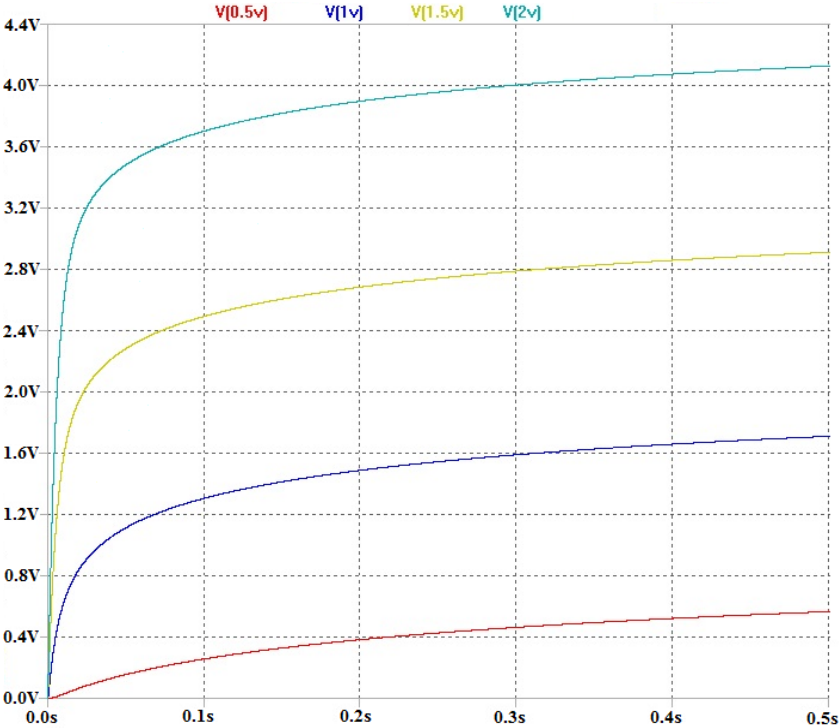

Figure 7. DC Voltage Output from Energy Harvesting Circuit for AC Voltages of 0.5V, 1V, 1.5V and 2V.

CONCLUSION

This paper investigated the use of energy harvesters for simultaneous structural health monitoring and powering of wireless sensor nodes. PVDF based energy harvesters were created in this regard. A finite element model of a reinforced concrete beam was created and the effects of localised damage investigated. It was found that the undamaged beam had a natural frequency of

73.10 Hz. With a localised crack of CDR = 0.05, the natural frequency shifted to 72.95 Hz and for CDR of 0.10 was found to be 72.56 Hz. An experimental analysis of an energy harvester bonded to a reinforced concrete beam was conducted. Through analysis of the voltage output of the harvester, it was found that the natural frequency of the beam was 74.32 Hz. With a localised crack of 0.05 CDR, the natural frequent was determined to be 72.62 Hz and 71.33 Hz for a CDR of 0.10. Through the use of the energy harvester, the presence of damage can be detected and through the use of an array of such, the location and magnitude of damage can be ascertained. The potential use of the energy harvested by these devices to power wireless sensor nodes was investigated. A voltage multiplier circuit was investigated in this regard. Through the rectifying of the AC voltage output from the harvester, an amplified DC current can be obtained which can, with the addition of a storage unit, be stored for use as the power supply for a wireless sensor node. This paper establishes the potential for using the energy harvesters as both a structural health monitoring device and power supply simultaneously.

REFERENCES

- [1] E. P. Carden, P Fanning. Vibration Based Condition Monitoring: A Review. *Structural Health Monitoring*, 3:355-377, December 2004.
- [2] A. Chukwujekwu Okafor, A. Dutta. Structural Damage Detection In Beams by Wavelet Transforms. *Smart Materials and Structures*, 9:906-917, December 2000.
- [3] M. O'Byrne, F. Schoefs, B. Chosh, V. Pakrashi. Texture Analysis Based Damage Detection of Ageing Infrastructural Elements, *Computer-Aided Civil and Infrastructure Engineering*. 28:162-177, March 2013.
- [4] J. W. Lee, J. D. Kim, C. B. Yun, J. H. Yi, J. M. Shim. Health-Monitoring Method for Bridges under Ordinary Traffic Loading, *Journal of Sound and Vibration*. 257:247-264, October 2002.
- [5] S. S. Law, X. Q. Zhu. Dynamic Behavior of Damaged Concrete Bridge Structures under Moving Vehicular Loads. *Engineering Structures*. 26:1279-1293, July 2004.
- [6] V. Pakrashi, O'Connor, A, B. Basu. A Bridge-Vehicle Interaction Based Experimental Investigation of Damage Evolution, *Structural Health Monitoring*, 9:285-296, July 2010.
- [7] S. Kim, S. Pakzad, D. Culler, J. Demmel, G. Fenves, S. Glaser, M. Turon. Health Monitoring of Civil Infrastructures Using Wireless Sensor Networks. *6th International Symposium on Information Processing in Sensors Networks*, 254-263, April 2007.
- [8] S. P. Beeby, M. J. Tudor, N. M. White. Energy Harvesting Vibration Sources for Microsystems Applications, *Measurement Science and Technology*, 17:175-195, December 2006.
- [9] S. F. Ali, M. I. Friswell, S. Adhikari. Analysis of Energy Harvesters for Highway Bridges, *Intelligent Material Systems and Structures*, 22: 1929-1938, November 2011.
- [10] A. Erturk. Piezoelectric Energy Harvesting for Civil Infrastructure System Applications: Moving Loads and Surface Strain Fluctuations, *Intelligent Material Systems and Structures*, 22: 1959-1973, November 2011.
- [11] G. Park, H. Sohn, C. R. Farrar, D. J. Inman. Overview of piezoelectric Impedance-Based Health Monitoring and Path Forward, *The Shock and Vibration Digest*, 35: 451-463, November 2003.
- [12] P. Cahill, N. Nuallain, N. Jackson, A. Mathewson, R. Karoumi, V. Pakrashi. Energy Harvesting from Train-Induced Response in Bridges, *Journal of Bridge Engineering*, 10.1061/(ASCE)BE.1943-5592.0000608.
- [13] G. K. Ottman, H. F. Hofmann, A. C. Bhatt, G. A. Lesieutre. Adaptive Piezoelectric Energy Harvesting Circuit for Wireless Remote Power Supply, *IEEE Transactions on Power Electronics*, 17:669-676, September 2002.
- [14] A. Rytter. Vibration Based Inspection of Civil Engineering Structures, *Ph.D. Thesis*, Aalborg University, Denmark, 1993.
- [15] R. Torah, P. Glynne-Jones, M. Tudor, T. O'Donnell, S. Beeby. Self-Powered Autonomous Wireless Sensor Node using Vibration Energy Harvesting. *Measurement Science and Technology*, 19, October 2008.