



Title	Using Mean Dynamic Force Patters in Calculations of Remaining Pavement Life
Authors(s)	O'Brien, Eugene J., Taheri, A.
Publication date	2010-09-02
Publication information	O'Brien, Eugene J., and A. Taheri. "Using Mean Dynamic Force Patters in Calculations of Remaining Pavement Life." Cork Institute of Technology, September 2, 2010.
Conference details	Bridge & Infrastructure Research in Ireland 2010, Cork, 2-3 September, 2010
Publisher	Cork Institute of Technology
Item record/more information	http://hdl.handle.net/10197/4065

Downloaded 2026-04-30 18:53:46

The UCD community has made this article openly available. Please share how this access benefits you. Your story matters! (@ucd_oa)



© Some rights reserved. For more information

Using Mean Dynamic Force Patterns in Calculations of Remaining Pavement Life

Eugene OBrien and Abdolrahim Taheri, University College Dublin.

1. Introduction and Context

Pavements deteriorate in response to forces applied by passing vehicles and as a result of environmental effects. The traditional approach to pavement life assessment considers all axle weights that are anticipated and calculates the number of equivalent axles of standard weight. It takes no account of dynamic oscillation of axle forces about the static weight. More significantly, the traditional approach to pavement assessment does not account for 'spatial repeatability', the fact that the mean pattern of dynamic forces applied by a fleet of trucks to a pavement, is repeatable. Many researchers (Hahn, 1985; Addis et al., 1986; Woodrooffe et al, 1988; Gyenes et al., 1992, O'Connor et al. 2000; Collop 1994; Cole and Cebon 1992) have presented evidence showing that for a given speed, the dynamic wheel force time histories generated by a particular heavy vehicle are concentrated and repeated at specific locations along the road for repeated test runs. Hahn (1985) suggests that because a large proportion of heavy vehicles tend to have similar geometry and dynamic characteristics, and tend to travel at a similar speed, spatial repeatability of pavement loading may be expected in normal traffic flow. O'Connor et al. (2000) show that individual patterns of force are not repeatable for similar vehicles at similar speed but that the mean of many force patterns are repeatable. Potter et al. (1994) also show the 'road damaging' ability of vehicles by spatial repeatability.

A mechanistic-empirical approach is implemented here to simulate the deterioration of a pavement. This framework, illustrated in Figure 1 (Collop and Cebon 1995, Cebon 1999), may include a dynamic vehicle/pavement interaction calculation to find the pattern of forces applied to the pavement. This is combined with a material response model to find the resulting stresses. These in turn are used to calculate pavement damage in the form of permanent deformation and loss of stiffness through fatigue. The permanent deformation (rutting) influences the vehicle/pavement dynamic interaction and a feedback loop is necessary to update the profile and recalculate the pattern of applied forces.

2. Statistical Spatial Repeatability

The vehicle/pavement dynamic interaction model, illustrated in Figure 2 for a quarter car (QC), is in effect a system of coupled differential equations. The differential equations describing the motion of the two-degree-of-freedom QC system are:

$$\begin{aligned}m_s \ddot{y}_u &= k_s (y_u - y_s) + c_s (\dot{y}_u - \dot{y}_s) \\m_u \ddot{y}_u &= -k_s (y_u - y_s) - c_s (\ddot{y}_u - \ddot{y}_s) + k_t (y_r - y_u)\end{aligned}$$

[Rahim – it is your job, not mine, to fix this kind of thing but I get the impression that you don't even look at it before sending it back to me. I don't have time for this. Here you have a figure with y_1 , y_2 , r , m_1 and m_2 and you have equations with y_u , y_s , m_u , m_s and y_r (which is probably a replacement for r). Please fix these things BEFORE presenting them to me for

checking. At this stage, I won't be looking at it again so you need to fix it yourself and submit.]

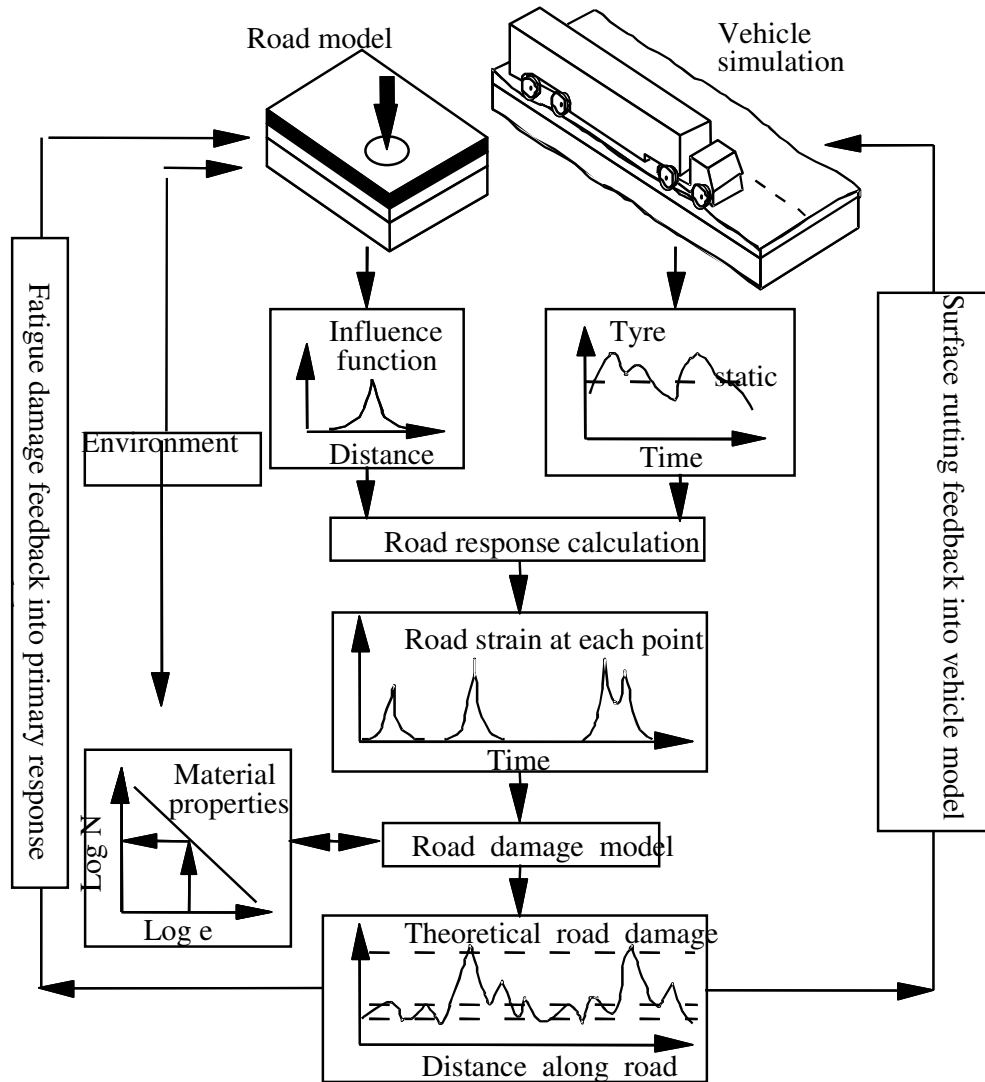

Figure 1: Long-term pavement performance framework (after Collop and Cebon 1995)

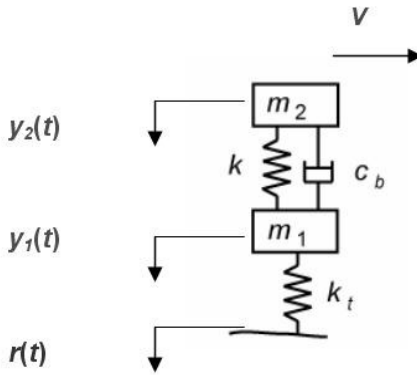

Figure 2: Quarter car model of vehicle axle

In this model, the unsprung mass (representing the mass of the wheels and axle) and sprung mass (representing part of the mass of the vehicle body) are denoted as m_u and m_s respectively. The suspension system is represented by a linear spring of stiffness k_s and a linear damper c_s , while the tyre is modelled by a linear spring of stiffness k_t . The terms, \dot{y}_s , \dot{y}_u , \ddot{y}_s are the corresponding velocities and accelerations. [Are these now consistent with the equations and the figure?]

The problem is complicated by the fact that there is significant variation in the vehicle fleet between the five parameters shown in Figure 2. To adequately address the problem of pavement damage in response to load, these five parameters need to be treated as random variables.

Figure 3 illustrates the average of 3 separate groups of 1000 wheel forces measured on a pavement in the Netherlands. The three patterns are similar, clearly illustrating what has been referred to as ‘statistical spatial repeatability’ (SSR) (O’Connor et al. 2000), i.e., the repeatability of *mean* patterns of force applied by a fleet of vehicles. In Figure 3 it can be seen for example that the mean applied force is greater at 9 m than it is at 19 m. It can be inferred that the former point will be more damaged than the latter, unless/until the SSR pattern changes.

[Rahim – you need to do the final checks before submitting including:

- that the same font and pitch is used everywhere (except in headings, etc.)
- that spaces like this one are finally removed (by moving around figures to the first available spot after they are first mentioned in the text, that does not create a blank space like this)
- that there are no missing spaces or double spaces or miss-spellings.
- that the references are ok. I already found two references that had not been referred to in the text and which must have come from the initial template – did you not check this? You need to check (a) that any reference mentioned in the text appears in the list at the end and (b) that everything in the list at the end is mentioned in the text.]

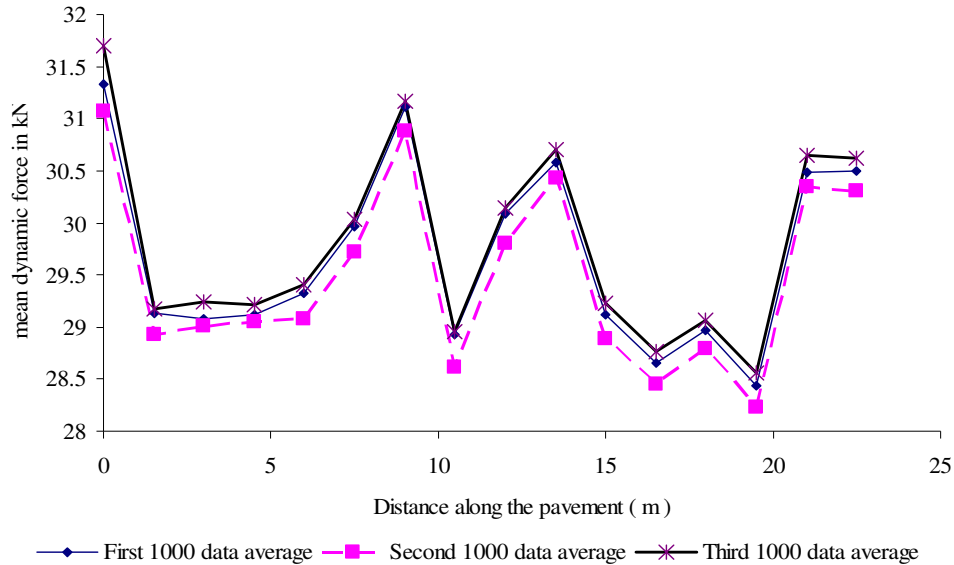

Figure 3: Patterns of statistical spatial repeatability for third wheel taken from a fleet of five axle vehicles (data courtesy of DVS)

Statistical Spatial Repeatability arises from the fact that, while every wheel passing the road is different, there are similarities between them and, when results are averaged over a large number such as a thousand wheels, the road profile induces a similar mean pattern of motion and applied force. While it is computationally demanding, this process can be reproduced in numerical simulations.

Monte Carlo simulation is a numerical method of generating ‘typical’ combinations of parameters given the statistical distributions of each parameter. For the pavement damage problem, Monte Carlo simulation is used to generate millions of combinations of parameters for the quarter car and hence to calculate millions of patterns of applied (static + dynamic) force.

3. Pavement Damage Model

The procedure shown in Figure 1 can be divided into four main areas: Dynamic Vehicle simulation; Pavement primary response calculation; Pavement damage calculation and Damage feedback mechanism. The inputs to the model are:

- (i) the details of the pavement being simulated (layer thicknesses, mix specifications etc);
- (ii) the time increments to be used in the simulations;
- (iii) the traffic loading and
- (iv) the climatic conditions.

From these initial specifications, a length of pavement surface profile is divided along its length into many equally spaced sub-sections. A time domain vehicle simulation is used to generate dynamic tyre forces for vehicles as a function of distance. A set of primary response ‘influence functions’ is generated, for each pavement sub-section and each mode of damage, here using the simplified Method of Equivalent Thickness (Ullidtz and Larsen, 1983). The modes of damage that are included in the model are structural rutting and fatigue damage to

the asphalt layers. These primary response influence functions are combined with the dynamic tyre forces, to give primary pavement response patterns, evaluated at a large number of equally spaced discrete points along the pavement. The primary responses are combined with the appropriate pavement damage models and the number of load applications, to predict damage (rutting and fatigue damage) as a function of distance along the pavement at any given time. An updated surface profile is then generated by subtracting the calculated rutting in the wheel path from the original profile used for that time increment. This mechanism accounts for the effects of changing surface profile on the pattern of statistical spatial repeatability and hence the pattern of mean dynamic tyre forces. The calculated fatigue damage is represented by reducing the elastic modulus of the asphaltic material for each subsection. This mechanism reflects the effects of cumulative fatigue damage on the primary responses and hence subsequent pavement damage. The above process is then repeated for the next time increment, and so on, until the pavement has reached the end of its serviceable life.

In this paper, a quarter car model is used, with Monte Carlo simulation, to simulate patterns of dynamic force on the pavement.

4. Results

The quarter car model is used, with the pavement damage model described above, to demonstrate the way in which a typical pavement responds to millions of cycles of load. In this model, Monte Carlo simulation is used to reproduce the variation in the vehicle fleet dynamic properties (represented here with just 5 properties as illustrated in Figure 2) and hence the variation in patterns of applied force as each axle passes. Despite great variation between individual patterns of applied force, SSR means that there is a consistency in the *mean* patterns. To illustrate the evolving pattern of mean forces, this approach is applied to an initial road profile that is perfectly smooth except for a pothole that is 2.5 mm deep and extends over a length of 3 m as illustrated in Figure 4. [Rahim – is this the ‘exact’ method, i.e., profile updated after EVERY cycle and every force pattern different?]

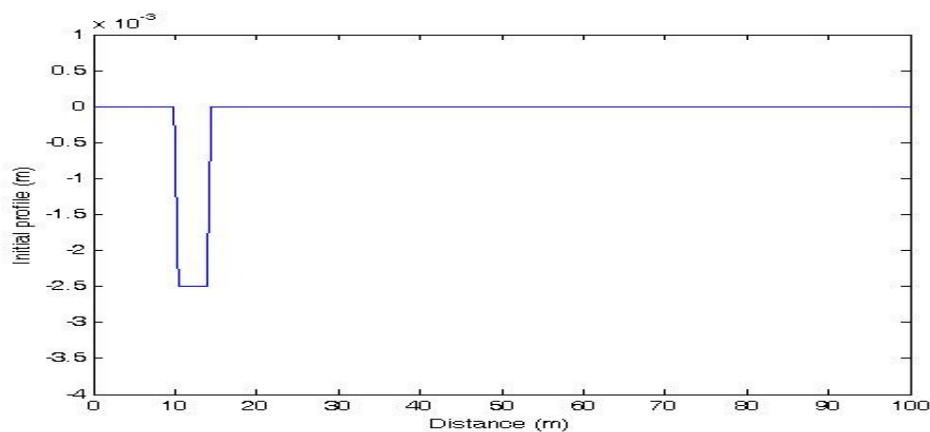

(a) Initial pothole profile

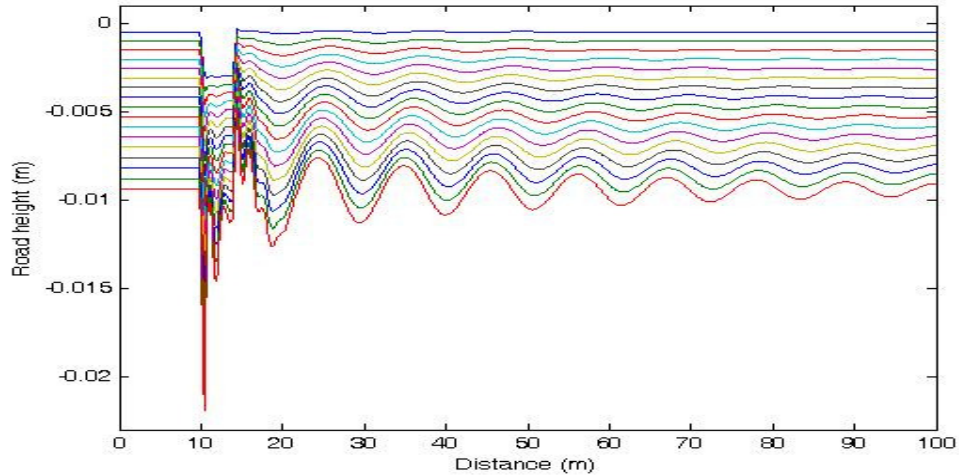

(b) Evolving surface profile due to damage

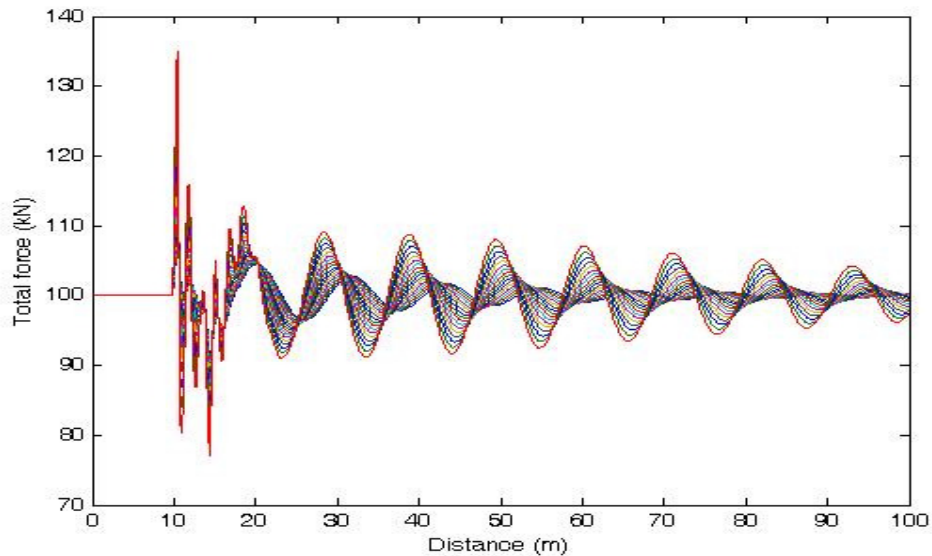

(c) Evolving force pattern due to damage

[Rahim – this is not clear to me. Is each of these curves the MEAN pattern of forces?

And, if so, is it the mean of each 2 million forces (it should be) (1st 2 million, 2nd 2 million, etc.)? Or is it the mean of all forces up to that time as you did before (mean of 1st 2 million, mean of 1st 4 million, mean of 1st 6 million, etc.)?]

Figure 4: Simulated evolution of pothole pavement profile and pattern of applied force throughout pavement life (every 2 million axles)

[Rahim – are the properties you chose for a wheel or an axle? The force you used is for an axle as you are assuming 10 tonnes. Are the stiffnesses for an axle or for a wheel – there is an important difference?]

Figure 4(c) shows that even such a tiny pothole excites the dynamics of the quarter car. It has an initial (static) weight of 100 kN to represent a heavy axle. The dynamic forces oscillate considerably about this static weight – by more than 30% at one stage. Figure 4(b) shows how the road profile changes during the pavement life in response to the mean pattern of

applied force. After 34 million passes, most of the profile has undergone a permanent deformation of almost 10 mm. However, deformations of double this amount have occurred in the pothole due to the high mean forces there. For a fixed set of properties (mass, stiffness, etc.), there are two natural frequencies in the quarter car model. In this simulation, each property is varying according to an assumed Normal distribution. Two mean frequencies can be seen in Figure 4, corresponding to mean axle hop (high frequency) and mean body bounce (low frequency) of the fleet. The axle hop is of high amplitude but its influence is local. The body bounce is of lower amplitude but its influence is more long lasting.

Figure 5 illustrates the evolving road surface profile and patterns of applied force for a randomly generated initial road profile of Class A (according to the ISO standard). Figure 5(a) illustrates how the road surface profile changes during the pavement life and Figure 5(b) shows the corresponding changes in the mean patterns of applied force. It can be seen that the profile undergoes permanent deformation at certain points (e.g., around 58.75 m) which results from a peak in mean force at that point. It is particularly interesting how both the road profile and the resulting pattern of forces change during the pavement life. For example, in the initial pattern of mean forces, there is no peak at 51 m; this develops later in its lifetime. The peaks in force come from the dynamic oscillation of the vehicle. They are therefore induced by a combination of the profile at a given time and the dynamic properties (including mean natural frequencies) of the QC vehicle.

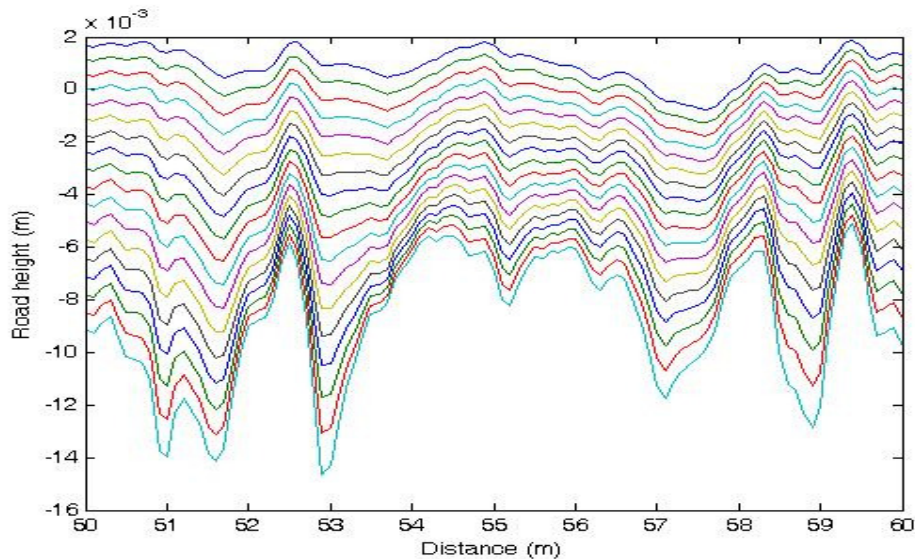

(a) Evolving surface profile due to damage

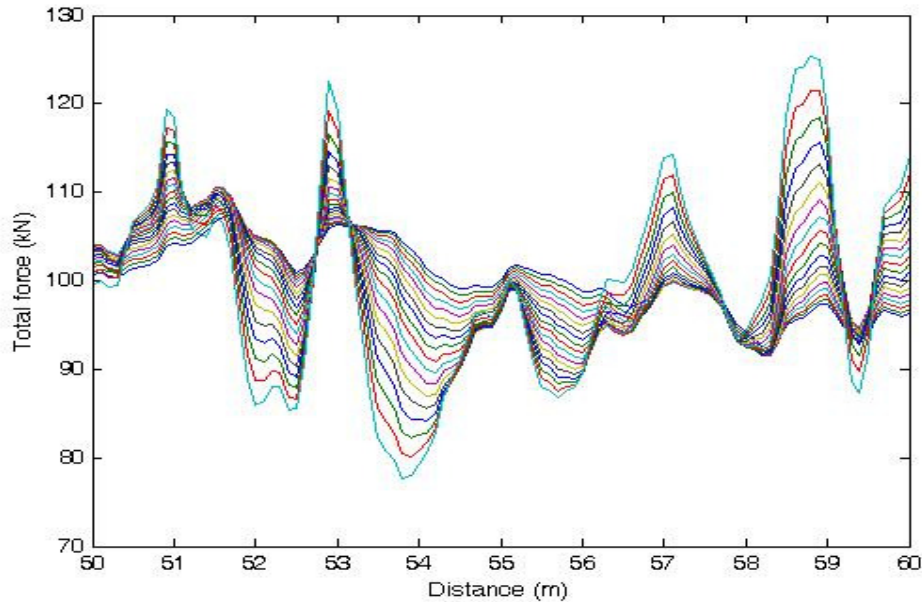

(b) Mean total (static + dynamic) force patterns

Figure 5: Simulated evolution of pavement surface and pattern of applied force for segment of pavement throughout pavement life (every 2 million axles)

5. Conclusions

This paper presents a mechanistic-empirical framework of pavement damage in response to applied forces. It highlights the importance of spatial repeatability and statistical spatial repeatability in the damage evolution during the pavement life. A simple pothole example shows that two vehicle fleet mean frequencies play an important role in pavement damage. For a more general profile, the process is not as clear cut but it can be seen that statistical spatial repeatability still plays a key role in the pavement damage process and should not be ignored in a pavement damage model.

References:

- Addis, R.R., Halliday, A.R., and Mitchell, C.G.B., (1986) 'Dynamic loading of road pavements by heavy goods vehicle.' *Congress on Engineering Design*, Seminar 4A-03, Birmingham, Institution of Mechanical Engineers.
- Cebon D., (1999). *Handbook of vehicle-road interaction*. Swets and Zeitlinger Publishers, Lisse.
- C.G.B. Mitchell, (1987). *The effect of the design of goods vehicle suspension on loads and bridges*, Project Report 115, Transport Research Laboratory, United Kingdom.
- Collop A.C. and Cebon D., (1995). 'Parametric study of factors affecting flexible-pavement performance.' *Journal of Transportation Engineering*, 485–494.

D.J. Cole, D. Cebon, (1992). 'Spatial repeatability of dynamic tyre forces generated by heavy Vehicles' , *Proc. Instn Mech. Engrs*, Part D, 206(D1), 17-27.

Hahn W.D., (1985). *Effects of Commercial vehicle design on road stress-vehicle research result*. Institut fur Krufffahrwesen, University Hanover (Translated by TRRL as WP/V ED/87/38).

M.S. Huhtala, J.T. Pihlajamak and P.A. Halonen, (1992). 'WIM and dynamic loading on pavements', in *Post Proceedings of Third International Symposium on Heavy Vehicle Weights and Dimensions*, eds. D. Cebon et al., Cambridge, United Kingdom, 272-277.

Potter, T.,E., C. , Collop, A., C., Cole D.,J., and Cebon D., (1994). *A mat Tests: Results and Analysis*. CUED/C-MECH/TR 61, University of Cambridge.

R.D. Ervin, (1983). *Influence of truck size and weight variables on the stability and control properties of heavy trucks* , Technical Report UMTRI-83-10/2, University of Michigan Transportation Research Institute.

T. O'Connor, E.J. OBrien, and B. Jacob, (2000). 'An Experimental Investigation of Spatial Repeatability', *Heavy Vehicles Systems, International Journal of Vehicle Design*, Vol. 7, No.1. 64-81.