



2950 Niles Road, St. Joseph, MI 49085-9659, USA  
269.429.0300 fax 269.429.3852 hq@asabe.org www.asabe.org

*An ASABE Meeting Presentation*

*Paper Number: 131620238*

## **An investigation into the efficacy of ozone for inactivation of microalgae cells in photobioreactors**

**Rachel M. Clarke<sup>1</sup>, Patrick J. Solan<sup>1</sup>, Brijesh. K. Tiwari<sup>2</sup>, Colm P. O'Donnell<sup>1</sup> and Thomas P. Curran<sup>1</sup>**

<sup>1</sup>UCD School of Biosystems Engineering, University College Dublin, Ireland

<sup>2</sup>Food and Consumer Technology, Manchester Metropolitan University, Manchester, UK

**Written for presentation at the  
2013 ASABE Annual International Meeting**

**Sponsored by ASABE**

**Kansas City, Missouri**

**July 21 – 24, 2013**

**Abstract.** *The sterilisation of photobioreactors is paramount to successful cultivation of microalgae. Due to the adhesive nature of microalgae, fouling of the light transmitting surfaces can be problematic. Traditional methods of sterilising photobioreactors between batches involve ultrasound, autoclaving or as seen in recent times, the photobioreactor incorporates a cleaning system. The objective of this project was to look at an alternative method of sterilisation. A preliminary study was carried out to determine the efficacy of ozone as treatment for the algae strain *Dunaliella tertiolecta*. Algae cultures at  $10^4$  cells CFU mL<sup>-1</sup> were exposed to 3-51  $\mu\text{g mL}^{-1}$  of ozone at different time periods (0-80 sec) and constant gas flow rates of 0.125 and 0.25 L min<sup>-1</sup>. Inactivation rates for total reduction of *D. tertiolecta* were found to increase significantly with an increase in ozone concentration and treatment time. This study supports the proposed mechanism of cell inactivation by ozone that causes cell membrane destruction and finally cell death. Therefore, it was found that ozone can be used to effectively eradicate microalgae in photobioreactors.*

**Keywords.** *Cell inactivation, *Dunaliella tertiolecta*, flow, microalgae, ozone, oxygen, photobioreactor*

---

The authors are solely responsible for the content of this meeting presentation. The presentation does not necessarily reflect the official position of the American Society of Agricultural and Biological Engineers (ASABE), and its printing and distribution does not constitute an endorsement of views which may be expressed. Meeting presentations are not subject to the formal peer review process by ASABE editorial committees; therefore, they are not to be presented as refereed publications. Citation of this work should state that it is from an ASABE meeting paper. EXAMPLE: Author's Last Name, Initials. 2013. Title of Presentation. ASABE Paper No. ---. St. Joseph, Mich.: ASABE. For information about securing permission to reprint or reproduce a meeting presentation, please contact ASABE at rutter@asabe.org or 269-932-7004 (2950 Niles Road, St. Joseph, MI 49085-9659 USA).

---

## Introduction

Rising worldwide demand for motor and power generation fuels, along with environmental concerns in terms of greenhouse gases (GHG) has motivated policy makers, scientists and technologists alike to consider alternative sources of energy (Gavand et al., 2007). First generation fuels have been mainly extracted from food and oil crops such as sugarcane, maize, rapeseed oil and sugar beet. This has caused controversy as the 'food versus fuel' debate has become one of the most contentious topics of the 21<sup>st</sup> Century (Kuchler & Linnér, 2012). While first generation crops alone cannot meet the current demand for fuel, third generation fuels which are derived from microorganisms such as yeast, fungi and microalgae appear to be a more promising feedstock (Peralta-Ruiz et al., 2013). The applications of microalgae include potential biofuel production, CO<sub>2</sub> fixation, biohydrogen production and bio-treatment of wastewater (Brennan & Owende, 2010). Microalgae have higher photosynthetic efficiencies, higher yields and growth rates compared to plant harvest (Harun et al., 2010). In terms of CO<sub>2</sub> mitigation, one kilogram of algal dry weight utilises around 1.83 kg CO<sub>2</sub> (Kumar et al., 2011). Microalgae require less cultivation space and can be cultivated in saline waters and in arid land areas (Lakaniemi et al., 2012) they also have the potential to produce more oil per hectare than any other feedstock being used to make biodiesel and they can be grown on land that is unsuitable for food crops (Rawat et al., 2013). Within 3–5 days, microalgae can start producing oil with a minimum yield oil of approximately 6.21 g of oil m<sup>-2</sup> day (~ 23 t oil ha<sup>-1</sup> yr<sup>-1</sup>) (Moheimani, 2013).

The genetic engineering of marine algae has been attracting an increasing amount of interest as a crucial technology in which to overcome the biomass problem in industrial applications (Qin et al., 2012). With the absence of cell differentiation, genetic manipulation of microalgae can be a much simpler system compared with higher plants as the allelic genes are usually absent because of the haploid nature of most vegetative stages of microalgae (Tabatabaei et al., 2011). Cultivation of microalgae in open pond systems may limit operational control (Brennan and Owende 2010) compared to photobioreactors that employ a more controlled cultivation environment with less risk of contamination; reduced CO<sub>2</sub> losses, prevention of water evaporation, improved harvesting and increased illumination area to volume ratio (Lakaniemi et al., 2012). One of the major disadvantages to microalgae cultivation is the rapid fouling of the light transmitting surfaces of the reactor due to the adhesive nature of microalgae (Rawat et al., 2013). This can lead to the reactor frequently being "taken offline" for mechanical cleaning and sterilisation, thus reducing production (Holtermann & Madlener, 2011). Some of the traditional methods of mechanical cleaning and sterilisation of photobioreactors involve autoclaving, ultrasonic cleaning or inbuilt systems that internally 'self-clean' the bioreactor (Wang et al., 2012). Sterilisation is important to prevent photobioreactor systems from undesired microorganisms that might reduce the system's efficiency (Holtermann & Madlener, 2011). The use of ozone is an alternative sterilisation method.

The algae strain *D. tertiolecta* is commonly used for microalgae cultivation (Francavilla et al., 2010). It is simple to cultivate in laboratories and it does not agglomerate on the surface (Chen et al., 2011). *D. tertiolecta* is a sensitive strain of algae as it lacks a rigid cell wall; it has a thin cytoplasmic membrane (Lakaniemi et al., 2012). These factors may contribute to rapid cell viability when exposed to ozone. Shear stress as a result of high gas velocities would rupture the already weak cell membrane along with the bactericidal effect of ozone. There are three regions in a bubble column where cell death might occur: 1) At the diffuser where the bubbles are formed; 2) In the region where the bubbles rise, and 3) At the surface where the bubble disengagement occurs (Lopes & Quinta-Ferreira, 2011).

The objective of this study was to investigate this hypothesis by investigating the efficacy of ozone for reduction of *Dunaliella tertiolecta* for the sterilisation of photobioreactors.

## Materials and methods

### The culturing of algae

The alga *Dunaliella tertiolecta* which is commonly found in saline waters was chosen as a model organism because of its abundant distribution and ease of culture (Gavand et al., 2007). Parent cultures of the algae strain *D. tertiolecta* were sourced from the Scottish Association for Marine Science's (SAMS) Culture Collection of Algae and Protozoa (CCAP) (Argyll, Scotland). The sea water used to culture the algae was sourced from EIRCOD (Cod Broodstock and Breeding Programme) of the Martin Ryan Institute (MRI), National University of Ireland, Galway. This water had been filtered through a 1.5 µm screen and treated with UV to kill any microorganisms. This seawater also provided the basis for creating the artificial seawater growth medium (F/2). Figure 1 shows the process involved in culturing algae.

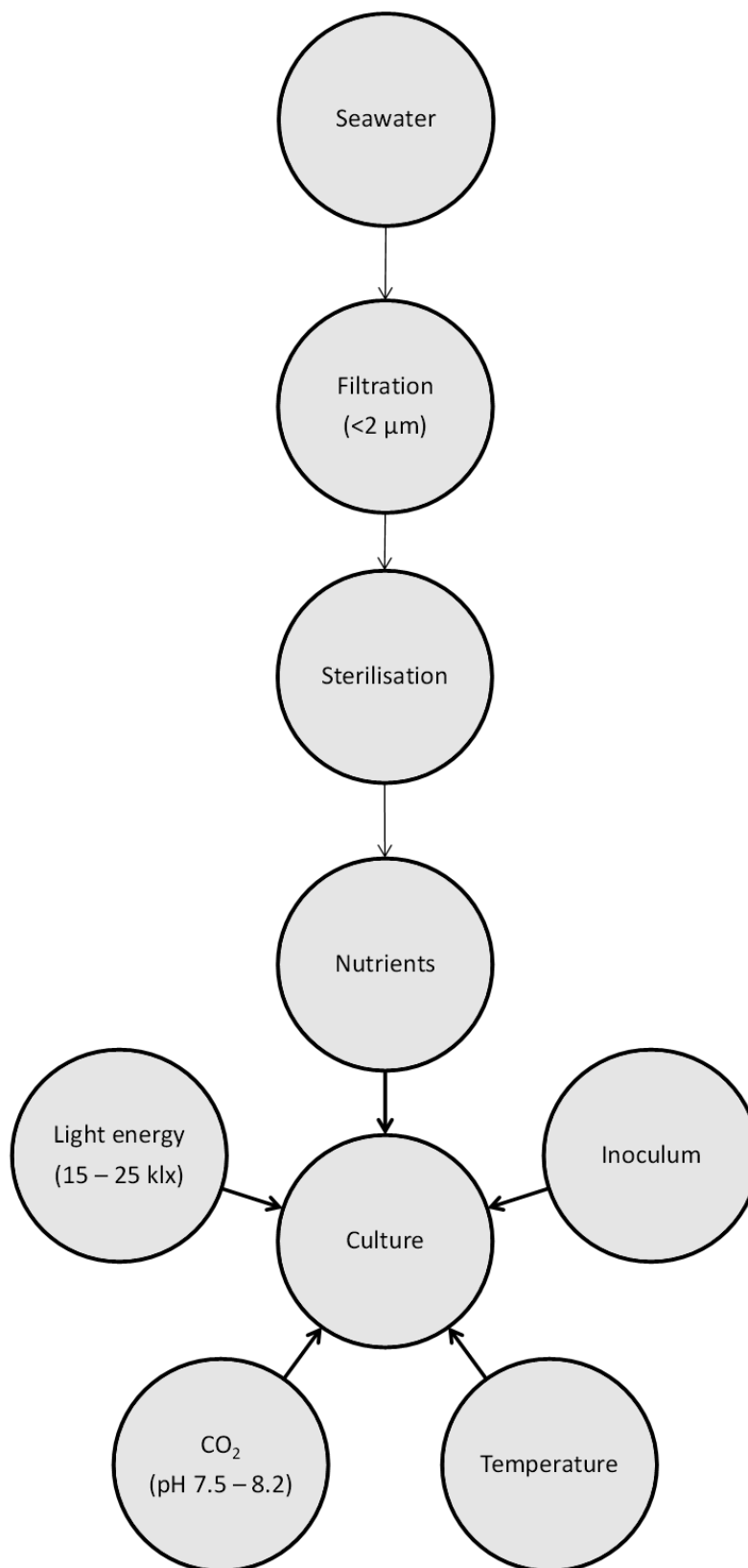

**Figure 1. The process of algal culture showing the various required inputs (Helm & Bourne, 2004)**

The treated media was inoculated with an F/2 medium which includes trace metals, vitamins solution and macronutrients ( $\text{NaNO}_3$ ,  $\text{NaHPO}_4$ ,  $\text{H}_2\text{O}$ ) adopted from Guillard and Ryther, (1963). To prepare the F/2 liquid growth medium for the stock algal cultures, 1 mL of macronutrients solution and 1 ml of trace metals solution

were added to the pre-treated Atlantic seawater and the medium was then autoclaved. 1 mL of the vitamins solution was added after autoclaving to prevent denaturing. The F/2 medium and stock cultures were maintained in a culture chamber at  $20 \pm 2$  °C under cool-white fluorescent lighting. Cultures were aseptically sterile-transferred every two-three days. The pH of the algae was recorded prior to ozone treatment using a pH meter (model Hanna Instruments, HI 122 pH/ORB/ Temperature Bench Meter).

### Media preparation

Seawater was collected from the Lower Falcorrib Pier, Co. Donegal, Ireland ( $54^{\circ}53'37.15''N$ ,  $8^{\circ}24' 20.91''W$ ) for the preparation of agar media. This location was chosen due to the exceptional water quality of the coast which was compliant with EU guide values (EPA, 2008). The collected seawater was first analysed for salinity using a digital salinity meter (Inolab, WTW series) and for pH using a hand held pH monitor (Thermo Scientific Orion 5-star plus, Cambridgeshire, England). A salinity reading using practical salinity units (PSU) equivalent to parts per thousand on a mass basis, was recorded. The seawater was filtered using grade 1 Whatman filter paper disc (5.5 cm in diameter; Whatman INC, Clifton, NJ) and a manual vacuum filtration method to remove all debris and organisms. The filtered seawater was then used to make nutrient agar.

To prepare the agar, 28 g of agar nutrient (Oxoid CMO325, Thermo Scientific), 1 litre of the Donegal filtered seawater and 1 mL of F/2 medium using the methods of Guillard and Ryther, (1963) were placed together in a 1 litre glass beaker and autoclaved (Rodwell scientific Instruments, MP 24, Essex, England) at  $121^{\circ}C$  for 15 minutes. When cooled, 0.5 mL of vitamin solution ( $B_{12}$ , biotin and Thiamine HCL) was added to ensure that adequate nutrients were available for algal growth. The agar was then poured into 90 mm petri plates under the cover of a laminar hood (Astec Microflow, Class II, UK) to maintain a sterile environment. The agar petri plates were allowed to set in a sterile environment for at least 24 hours before use.

### Ozone system design

The temperature of the algae was measured and recorded before 50 mL of the algae strain *D. tertiolecta* was placed into a 100 mL bubble column reactor with built in diffuser (Ozone Labs™, Ozone Services, Burton, B.C., Canada as shown in Figure 2). Ozone was generated using a corona discharge ozone generator (model OL80A/DLS, Ozone Services, Burton, B.C., Canada). Pure oxygen was supplied via an oxygen cylinder (Air Products Limited, Dublin, Ireland) and the flow rate was controlled using an oxygen flow regulator. The presence of ozone was detected by using an ozone sensor (Model OS-3, Eco Sensors, INC) which was placed above the bubbling fluid column. Ozone gas concentrations were determined using an ozone gas analyser. Untreated ozone from the bubble column reactor was passed through an ozone destructor (Lasco Fittings Inc, USA) as shown in Figure 2.

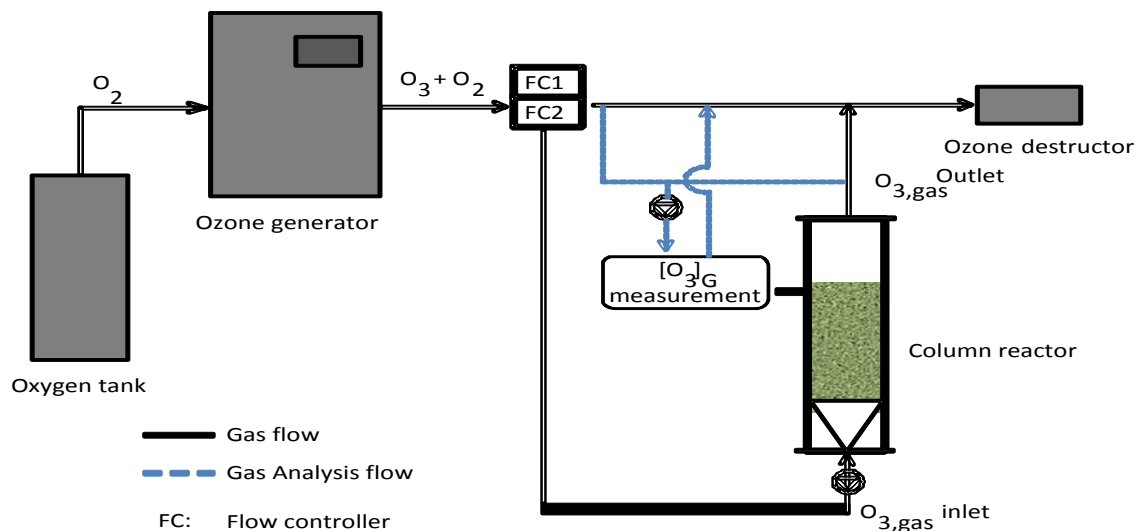

Figure 2. Schematic of ozone treatment

Flow rates of 0.125 and 0.25 L min<sup>-1</sup> with a variable ozone concentration of 3-29 µg mL<sup>-1</sup> were applied to the algae for varying time periods as shown in Table 1.

Table 1. Ozone concentration at two selected gas flow rate

Flow rate (L min <sup>-1</sup> )	Ozone concentration (µg mL <sup>-1</sup> )		
0.125	5	17	29
0.25	3	9	13

Ozone was diffused through 50 mL algae culture samples. Initial samples were treated with ozone for 5 minutes at an ozone concentration of 51 µg mL<sup>-1</sup> and a flow rate of 0.625 L min<sup>-1</sup>. A 2 ml aliquot was removed every 60 s over a 5 min period using a micropipette (Thermo Scientific, Finn pipette F2 [1-10 ml], Cambridgeshire, England) and disposable tips. Subsequently the exposure time was reduced to 1 min with 2 ml aliquots removed every 15 s. All experiments were carried out in duplicate and replicated three times. Algae samples were also exposed to oxygen only as a control measure for the same periods of time; this was also duplicated and replicated three times.

### Laboratory analysis

To prepare a salinity buffer for the dilution series, 42 g of sodium chloride (FLINN, Scientific, Inc, 2008) was added to 350 ml of distilled water. 9 mL of the sodium chloride solution was placed into each of the test tubes before being autoclaved at 121°C for 15 min. The test tubes were allowed to cool for a period of up to 24 hours before use.

Following ozone treatment all ozonated aliquots underwent a dilution series up to a dilution of 10<sup>-4</sup> under a laminar hood. To ensure proper mixing the test tubes were placed on a vortex (Scientific Industries, INC, USA). 200 µl of each dilution was surface spread onto labelled agar nutrient petri plates. Each dilution was plated in duplicate to ensure accuracy and consistency. All completed plates were placed into an incubation chamber (Thermo Scientific, Precision compact, Cambridgeshire, England) set at 37°C for 72 hours. The efficacy of treatments was determined in terms of viable cell counts following the 72 hour period in the incubation chamber.

### Plate counting and analysis

After 72 hours the incubated plates were manually counted. The results were reported as colony forming units (CFU mL<sup>-1</sup>). The data was converted exponentially using Microsoft Excel for all graphical representations. All data was pooled and values averaged and standard deviations determined.

### Cell inactivation kinetics

#### Weibull modelling

The reductions in the algal cell count (log<sub>10</sub> CFU mL<sup>-1</sup>) population following ozone treatment were fitted to Weibull kinetic model to analyse the algal cell inactivation. Weibull models [Eq.1] were fitted using GlnaFit software tool as described by (Geeraerd, 2005).

$$\text{Log}_{10}(N_t) = \text{Log}_{10}(N_0) - \left[ \frac{t}{\delta} \right]^\beta \quad (1)$$

Herein,  $N_t$  represents the algal cell counts (Log<sub>10</sub> CFU mL<sup>-1</sup>);  $N_0$  is the initial algal cell counts (Log<sub>10</sub> CFU mL<sup>-1</sup>);  $\beta$  is the shape factor. The shape parameter provides a flexibility which takes concave shape ( $\beta < 1$ ) or convex shape ( $\beta > 1$ ). The  $\delta$  parameter is the decimal reduction time (min), i.e. the time taken to achieve a 1 log or 90% reduction in the algal cell count.

## Results and discussion

The effects of ozone on algae species *D. tertiolecta* were determined by measuring the cell counts of the algae

after a 72 h incubation period. The effect of ozone exposure time (s) on algae cell inactivation at a flow rate  $0.125 \text{ L min}^{-1}$  show that at lower ozone concentrations of  $5$  and  $17 \mu\text{g mL}^{-1}$ , cell inactivation had decreased significantly up to  $30$  s of exposure with a  $2.0$  log reduction within  $60$  s. However, when ozone concentration was increased to  $29 \mu\text{g mL}^{-1}$  there was a notable difference in cell inactivation rates which resulted in a  $4.0$  log reduction in  $60$  s as shown in Figure 3.

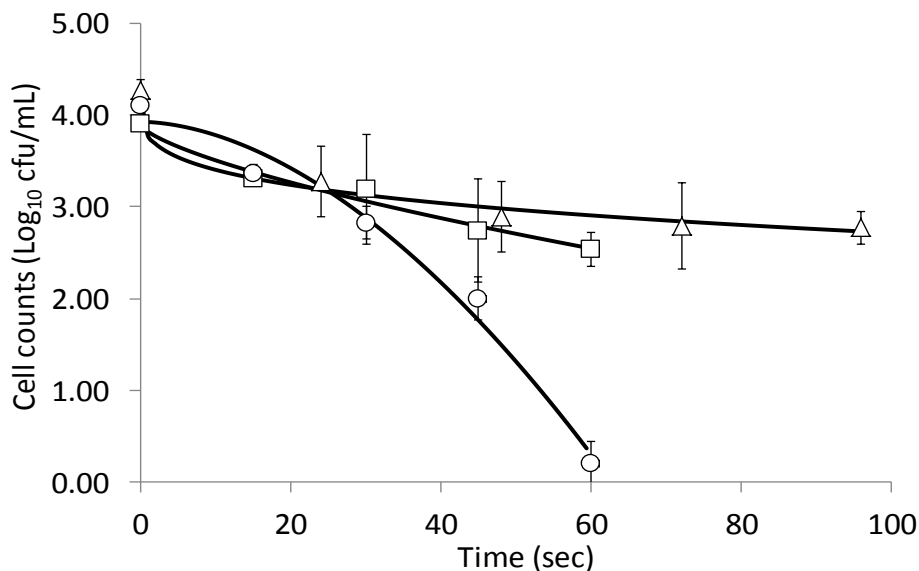

Figure 3. Reduction in algal cell counts ( $\log_{10}\text{CFU mL}^{-1}$ ) at gas flow rate of  $0.125 \text{ L min}^{-1}$  and ozone concentrations of  $5 \mu\text{g mL}^{-1}$  ( $\Delta$ ),  $17 \mu\text{g mL}^{-1}$  ( $\square$ ) and  $29 \mu\text{g mL}^{-1}$  ( $\circ$ ) respectively

The effects of ozone exposure time (s) on algae cell inactivation at a flow rate of  $0.25 \text{ L min}^{-1}$  show that at the lower ozone concentration of  $3 \mu\text{g mL}^{-1}$ , cell inactivation rates from initial population had resulted in a  $2.0$  log reduction within  $60$  s of ozone exposure. When ozone concentrations were increased to  $9$  and  $13 \mu\text{g mL}^{-1}$ , cell inactivation rates had significantly reduced from initial populations with a  $3.0$  log cycle reduction observed in both ozone concentrations after  $60$  s as shown in Figure 4.

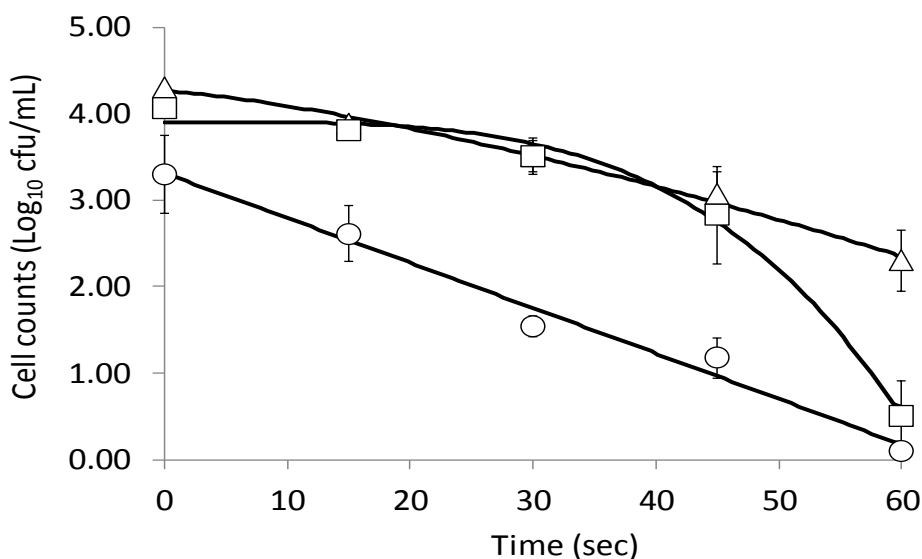

Figure 4. Reduction in algal cell counts ( $\log_{10}\text{CFU mL}^{-1}$ ) at gas flow rate of  $0.25 \text{ L min}^{-1}$  and ozone concentrations of  $3 \mu\text{g mL}^{-1}$  ( $\Delta$ ),  $9 \mu\text{g/ml}$  ( $\square$ ) and  $13 \mu\text{g mL}^{-1}$  ( $\circ$ ) respectively.

The inactivation of algae cells was fitted using the Weibull model, which provided estimations of cell inactivation in terms of ozone exposure time required. The Weibull model fitted well to describe the inactivation kinetics of algal cells with all coefficients of determination ( $R^2$ ) greater than 0.93 and RMSE <0.29. D value and shape factor ( $\beta$ ) obtained using Equation 1 with corresponding regression coefficient ( $R^2$ ) and root mean square error (RMSE) are shown in Table 2. The flow rate 0.25 L min<sup>-1</sup> showed a significant reduction in cell viability after 30 s (Figure 4). D value was found to increase from 132.41 min to 19.39 min with an increase in ozone concentration from 0 to 13 µg mL<sup>-1</sup> at a flow rate of 0.25 L min<sup>-1</sup>. A similar increase in D value was also observed for 0.125 L min<sup>-1</sup> (Table 2). Non zero D values of 132.41 min and 112.82 min at a flow rate of 0.25 L min<sup>-1</sup> and 0.125 L min<sup>-1</sup> respectively show that inactivation is solely due to oxygen. The oxygen proportion in the feed gas plays a synergistic role in cell inactivation. Algal cell survival curves showed both the upward concavity (shoulder) and downward concavity (tail) depending on the ozone concentration and flow rate. Shape factor ( $\beta$ ) was found to be >1 in the case of 0.25 L min<sup>-1</sup> except for 0 µg mL<sup>-1</sup>, however,  $\beta$ >1 was observed in the case of µg mL<sup>-1</sup> and 29 µg mL<sup>-1</sup> at a gas flow rate of 0.125 L min<sup>-1</sup>. The Weibull model is flexible owing to the inclusion of a shape constant in addition to the rate constant and has been employed to describe microbial, enzymatic and chemical degradation kinetics (Cullen et al., 2009). The Weibull distribution is employed for several microbial inactivation of various food borne pathogens such as *Listeria innocua*, *L. monocytogenes*, *S. enteritidis*, *S. typhimurium*, *E. coli* O157:H7 and *Staphylococcus aureus*, which exhibited a downward or upward concavity in the survival curves processed using novel non-thermal and classical food processing technologies (Bialka et al., 2008).

Table 2. Weibull model parameters for algal cell counts

Gas flow rate (L min <sup>-1</sup> )	Ozone concentration (µg/mL)	Delta (δ, sec)	Shape factor (β)	RMSE	R <sup>2</sup>	R <sup>2</sup> <sub>adj</sub>
0.25	0	132.41±82.08	0.45±0.23	0.11	0.93	0.86
	3	37.32±3.81	1.35±0.23	0.11	0.99	0.98
	9	43.29±2.38	3.74±0.58	0.17	0.99	0.99
	13	19.39±5.02	1.01±0.21	0.22	0.98	0.97
0.125	0	112.82±14.74	2.45±0.50	0.01	0.99	0.97
	5	22.45±12.50	0.27±0.09	0.11	0.98	0.97
	17	38.92±7.45	0.69±0.17	0.11	0.98	0.96
	29	29.27±5.51	1.79±0.43	0.29	0.98	0.96

### Effect of ozonation on algae colour

During ozonation, a significant change in the colour of algal cells was detected as a result of ozone concentration. Figure 5 shows the effect of ozonation on algae cells after an ozone exposure of 29 µg mL<sup>-1</sup> and 0.125 L min<sup>-1</sup> flow rate up to 60 s. As the ozonation of algae took place, one obvious factor that gave an indication that there was a difference in the viability of algae cells was the colour change of the algae, which is not to say that algae colour change is representative of algae cell death. The change in colour is due to the oxidation of the algae. Ozone is a powerful oxidant and is reported to oxidise colour pigments mainly due to direct reaction with ozone or indirect reaction of secondary oxidators (Cullen et al., 2009).

### Factors that contribute to high algae cell mortality

There are several factors that contribute to the effectiveness of ozone on cell mortality. The contact time of ozone, the concentration of ozone and the ozone demand of the algae all determine the extent to which ozone is effective (Kureshy et al., 1999). An explanation for the reduction in algae cell counts may lie in the theory of shear stress. Cell damage due to shears stress has been referred to as the key problem in cultures of microalgae (Barbosa, 2003). In a study of shears sensitivities by Chisti (2009) growth of *D. tertiolecta* declined due to increased aeration rates in a bubble column reactor due to hydrodynamic stresses in the fluid. The death rate increased with superficial gas velocities for gas velocities exceeding 0.6 mL min<sup>-1</sup>. Decreasing the flow rate caused a marginal reduction in the specific death rate.

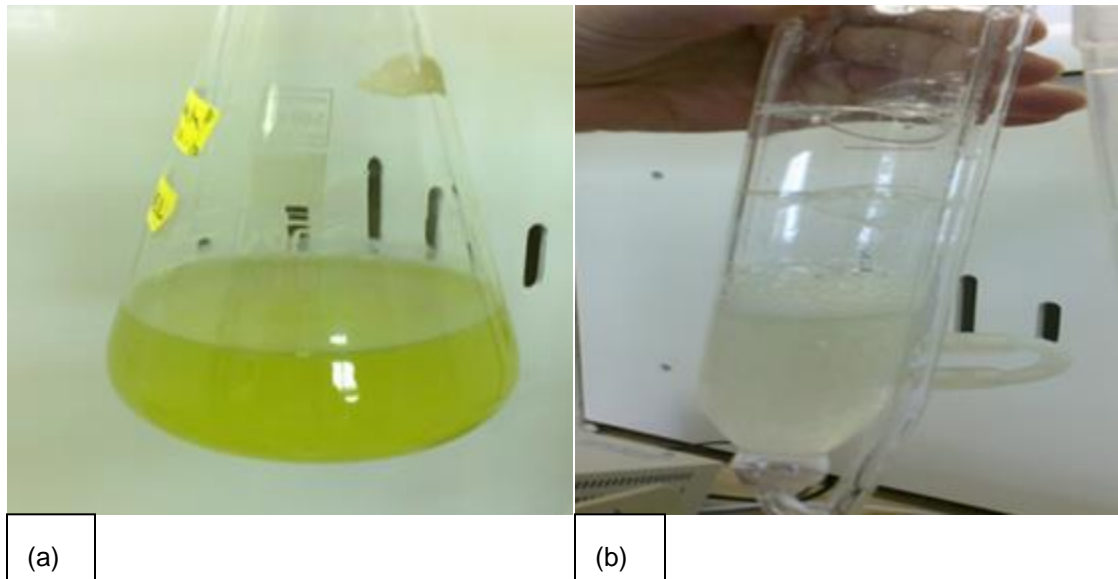

Figure 5. Colour changes of the algae (a) pre-ozonation and (b) after 60 s exposure to ozone

Other considerations for reduced mean cell counts are the oxygen flow rate and bubble formation. The results show that the optimum flow rate is  $0.125 \text{ L min}^{-1}$  at an ozone concentration of  $29 \mu\text{g mL}^{-1}$ . This is because at lower flow rates, ozone concentration increases (Tizaoui & Zhang, 2010). Higher oxygen flow rates usually produce larger bubbles whereas lower flow rates produce smaller bubbles (Kukuzaki et al., 2010). At high flow rates, a small number of large bubbles are produced that rapidly rise to the surface and escape the media at an uncontrollable rate (Vijayan & Patil, 2010). If an anti-foaming agent is not used at higher oxygen flow rates, most of the liquid volume can be lost through the head of the bubble column. No anti-foam agents were used in this project, foaming of bubbles and loss of liquid volume was experienced at the higher oxygen flow rate of  $0.25 \text{ L min}^{-1}$ .

Barbosa (2003) found that ozone transfer from the bubble to the algae culture happens only on the surface of the bubble where ozone is in direct contact with the solution. Ozone may be trapped inside the bubble in which it does not do anything but creates a strong ozone gas odour. Smaller bubbles are more preferable as the surface to volume ratio is increased as more ozone in the bubbles will be in direct contact with the algae solution. Chisti (2009) found that shear stress caused by high gas velocities can cause injury or even cell death to algae populations. Wang et al (1994) concluded that the principal determinants of cell damage were cell-bubble encounter rate which is the rate of bubble break up within the fluid and the bursting rate at the surface. This has led to a common opinion among researchers within the field of microalgae cultivation that microalgae are shear sensitive. It has also been suggested that column height results in an increase of cell death. Jobses et al. (1991) reported that the bubble break up at the liquid surface is the cause for cell damage; the death rate will be proportional to the gas flow rate per unit volume. Camacho et al. (2001) found that there was a relationship between fluid height and cell attachment to bubbles. A greater height of rise means that more cells can be captured by the rising bubbles and carried to the surface where cells die as the bubbles rupture.

It may be argued that the algae were already near the 'death phase' but the premise of the project was to investigate the effects of ozone on algae cell viability after harvesting within a photobioreactor. It was imperative to the study to simulate photobioreactor conditions, and that meant using at least ten - day old algae. However studies on algae found that younger algae are most resistant to ozone (Heath, 1984). Based on the results of this experiment, ozone treatment of algae was found to be a reliable method to cause cell mortality. As an organism that is relatively susceptible to the effects of ozone, *D. tertiolecta* is an ideal organism in which to cultivate for biofuel or as a mitigation factor for carbon dioxide.

## Conclusion

The algae strain *Dunaliella tertiolecta* was exposed to ozone concentrations  $3\text{-}29 \mu\text{g mL}^{-1}$  and flow rates of  $0.125$ , and  $0.25 \text{ L min}^{-1}$  at varying time periods. Effective cell death was evident at 45 seconds at a flow rate of  $0.125 \text{ ml min}^{-1}$  and ozone concentration of  $29 \mu\text{g mL}^{-1}$  and for up to 60 seconds at a flow rate of  $0.125 \text{ L min}^{-1}$

and ozone concentration of 17 µg mL<sup>-1</sup>.

## Acknowledgements

The authors would like to thank Damien Farrelly for the cultivation of the algae, Azra Czar for her assistance with the experiments and Rachel Halpin for all her help and expertise in microbiology.

## References

- Barbosa, M.J.G.V. 2003. Microalgae photobioreactors: scale up and optimisation, Vol. PhD, Wageningen University, The Netherlands. The Netherlands.
- Bialka, K.L., Demirci, A., Puri, V.M. 2008. Modeling the inactivation of Escherichia coli O157:H7 and Salmonella enterica on raspberries and strawberries resulting from exposure to ozone or pulsed UV-light. *Journal of Food Engineering*, **85**(3), 444-449.
- Brennan, L., Owende, P. 2010. Biofuels from microalgae—A review of technologies for production, processing, and extractions of biofuels and co-products, Vol. 14, *Renewable and Sustainable Energy Reviews*, pp. 557-577.
- Camacho, F.G., Grima, E.M., Miron, A.S., Pascual, V.G., Chisti, M.Y. 2001. Carboxymethyl cellulose protects algal cells against hydrodynamic stress. in: *Enzyme Microb*, Vol. 29, pp. 602-610.
- Chen, M., Tang, H., Ma, H., Holland, T.C., Ng, K.Y.S., Salley, S.O. 2011. Effect of nutrients on growth and lipid accumulation in the green algae *Dunaliella tertiolecta*. *Bioresource Technology*, **102**(2), 1649-1655.
- Chisti, Y., Zealand, M.U.S.o.E.P.N.N. 2009. *Shear Sensitivity*. John Wiley & Sons, Inc.
- Cullen, P.J., Tiwari, B.K., O'Donnell, C.P., Muthukumarappan, K. 2009. Modelling approaches to ozone processing of liquid foods. *Trends in Food Science & Technology*, **20**(3-4), 125-136.
- EPA. 2008. Estuarine and coastal waters report, Vol. 2013.  
<http://www.epa.ie/downloads/pubs/other/indicators/irlenv/43366%20epa%20report%20chap%202091.pdf> [Accessed 28<sup>th</sup> February, 2013]
- Francavilla, M., Trotta, P., Luque, R. 2010. Phytosterols from *Dunaliella tertiolecta* and *Dunaliella salina*: A potentially novel industrial application. *Bioresource Technology*, **101**(11), 4144-4150.
- Gavand, M.R., McClintock, J.B., Amsler, C.D., Peters, R.W., Angus, R.A. 2007. Effects of sonication and advanced chemical oxidants on the unicellular green alga *Dunaliella tertiolecta* and cysts, larvae and adults of the brine shrimp *Artemia salina*: A prospective treatment to eradicate invasive organisms from ballast water. *Marine Pollution Bulletin*, **54**(11), 1777-1788.
- Geeraerd, A.H.V., V. P. Van Impe, J.F. 2005. GlnaFIT, a freeware tool to assess non-log-linear microbial survivor curves. **102**(1), 95-105.
- Guillard, R., Ryther, J. 1963. Studies on marine planktonic diatoms. I. *cyclotella nana* Husted and *Detonula confervacea* Cleve. in: *Can J Microbiol*, Vol. 8, pp. 229-239.
- Harun, R., Singh, M., Forde, G.M., Danquah, M.K. 2010. Bioprocess engineering of microalgae to produce a variety of consumer products. *Renewable and Sustainable Energy Reviews*, **14**(3), 1037-1047.
- Heath, R.L. 1984. Decline in energy reserves of *Chlorella Sorokiniana* upon exposure to ozone, Vol. 76, *Plant physiology*, pp. 700-704.
- Helm, M.M., Bourne, N. 2004. *The Hatchery culture of bivalves: a practical manual*. Food and Agriculture Organization, Rome.
- Holtermann, T., Madlener, R. 2011. Assessment of the technological development and economic potential of photobioreactors. *Applied Energy*, **88**(5), 1906-1919.
- Jobses, I., Marker, D., Ramper, J.A. 1991. Lethal events during gas sparging in animal cell culture. in: *Biotechnol Bioengineering*, Vol. 37, pp. 484-490.
- Kuchler, M., Linnér, B.-O. 2012. Challenging the food vs. fuel dilemma: Genealogical analysis of the biofuel discourse pursued by international organizations. *Food Policy*, **37**(5), 581-588.
- Kukuzaki, M., Fujimoto, K., Kai, S., Ohe, K., Oshima, T., Baba, Y. 2010. Ozone mass transfer in an ozone-water contacting process with Shirasu porous glass (SPG) membranes—A comparative study of hydrophilic and hydrophobic membranes. *Separation and Purification Technology*, **72**(3), 347-356.
- Kumar, K., Dasgupta, C.N., Nayak, B., Lindblad, P., Das, D. 2011. Development of suitable photobioreactors for CO<sub>2</sub> sequestration addressing global warming using green algae and cyanobacteria. *Bioresource Technology*, **102**(8), 4945-4953.
- Kureshy, N., Davis, D.A., Arnold, C.K. 1999. Effect of ozone treatment on cultures of *Nannochloropsis occulata*, *Isochrysis galbana* and *Chaetoceros gracilis*, Vol. 30, *Journal of the world aquaculture society*, pp. 473-480.
- Lakaniemi, A.M., Intihar, V.M., Tuovinen, O.H., Puhakka, J.A. 2012. Growth of *Dunaliella tertiolecta* and associated bacteria in photobioreactors. *J Ind Microbiol Biotechnol*, **39**(9), 1357-65.
- Lopes, R.J.G., Quinta-Ferreira, R.M. 2011. Detoxification of high-strength liquid pollutants in an ozone bubble column reactor: Gas-liquid flow patterns, interphase mass transfer and chemical depuration. *Chemical Engineering Journal*, **172**(1), 476-486.
- Moheimani, N. 2013. Long-term outdoor growth and lipid productivity of *Tetraselmis suecica*, *Dunaliella tertiolecta* and *Chlorella* sp (Chlorophyta) in bag photobioreactors. *Journal of Applied Phycology*, **25**(1), 167-176.
- Peralta-Ruiz, Y., González-Delgado, A.D., Kafarov, V. 2013. Evaluation of alternatives for microalgae oil extraction based on exergy analysis. *Applied Energy*, **101**(0), 226-236.
- Qin, S., Lin, H., Jiang, P. 2012. Advances in genetic engineering of marine algae. *Biotechnology Advances*, **30**(6), 1602-1613.

- Rawat, I., Ranjith Kumar, R., Mutanda, T., Bux, F. 2013. Biodiesel from microalgae: A critical evaluation from laboratory to large scale production. *Applied Energy*, **103**(0), 444-467.
- Summerfelt, S.T., Hochheimer, J.N. 1997. Review of ozone processes and applications as an oxidising agent in aquaculture., Vol. 59, *The progressive fish culturist.*, pp. 94-105.
- Tabatabaei, M., Tohidfar, M., Jouzani, G.S., Safarnejad, M., Pazouki, M. 2011. Biodiesel production from genetically engineered microalgae: Future of bioenergy in Iran. *Renewable and Sustainable Energy Reviews*, **15**(4), 1918-1927.
- Tizaoui, C., Zhang, Y. 2010. The modelling of ozone mass transfer in static mixers using Back Flow Cell Model. *Chemical Engineering Journal*, **162**(2), 557-564.
- Vijayan, T., Patil, J.G. 2010. High concentration ozone generation in the laboratory for various applications. in: *International Journal of Science and Technology Education Research*, Vol. 1, Academic Journals, pp. 132-142.
- Wang, B., Lan, C.Q., Horsman, M. 2012. Closed photobioreactors for production of microalgal biomasses. *Biotechnology Advances*, **30**(4), 904-912.
- Wang, N.Y.J.-D.Y., Richard V. Calabrese, Kuo-Ching Chang. 1994. Unified modeling framework of cell death due to bubbles in agitated and sparged bioreactors. *Journal of Biotechnology*, **33**(2), 107-122.
- Wu, D., Yang, Z., Wang, W., Tian, G., Xu, S., Sims, A. 2012. Ozonation as an advanced oxidant in treatment of bamboo industry wastewater. *Chemosphere*, **88**(9), 1108-1113.